

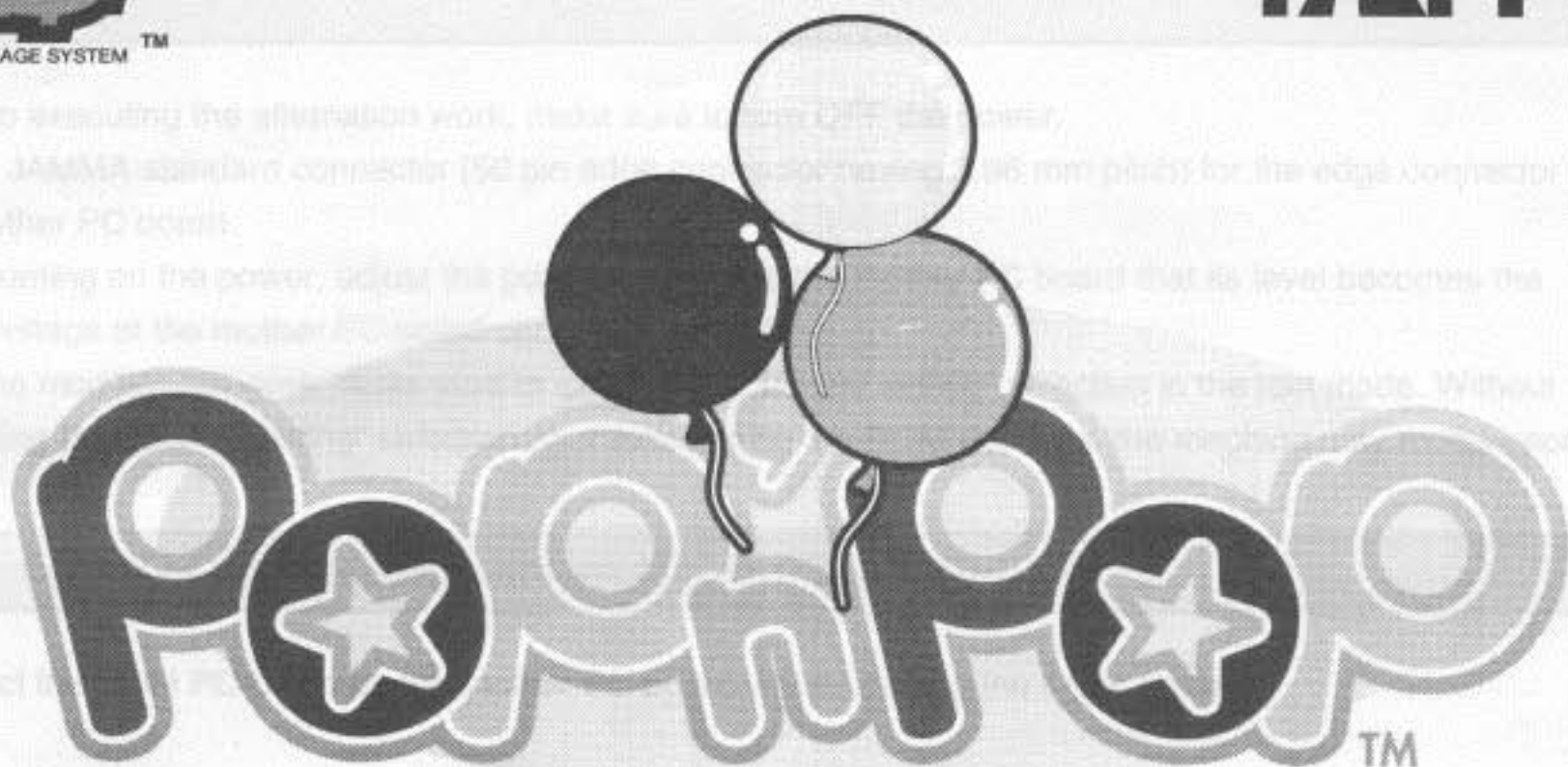

TAITO®

- Prior to commencing the installation work, check the power supply.
- Use a JAMMA standard connector (52 pin edge connector) with a 2.54 mm pitch for the edge connector of the mother PC board.
- After installing all the power, confirm the power supply voltage that is level according to the rated voltage of the mother PC board.
- After the work is completed, turn off the power supply in the power switch. Without



POP'N POP

# Instruction Manual

## ⚠ Caution

- To use this machine safely and correctly, read this manual carefully and make sure you fully understand the contents before using the machine.
- After reading this manual, keep it in a designated place so that it can be referenced by others anytime.

TAITO CORPORATION®

G2500872A

## [Cautions]

- Prior to executing the alternation work, make sure to turn OFF the power.
- Use a JAMMA standard connector (56 pin edge connector having 3.96 mm pitch) for the edge connector of the mother PC board.
- After turning on the power, adjust the power supplied to the mother PC board that its level becomes the rated voltage at the mother PC board connector section.
- After the modification work, make sure to execute the "factory setting" selection in the test mode. Without executing the "factory setting" selection after exchanging the ROM package, the machine may malfunction.

## [Connection of mother PC board and ROM PC board]

- Connect the ROM PC board on the mother PC board while referring the figure below.

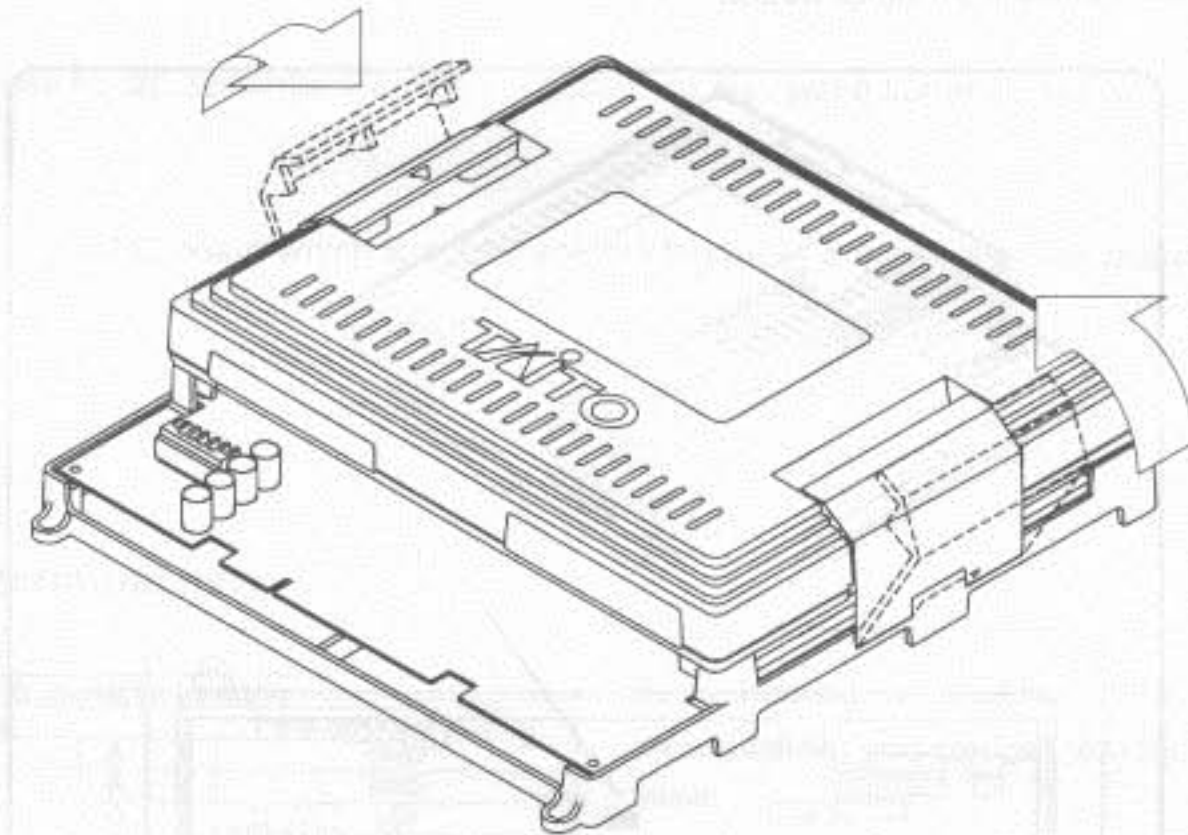

\* Be careful about direction of the ROM PC board.

## [Specifications of operation panel]

- 1 × 2 8-directional joystick
- 2 × 2 button switches

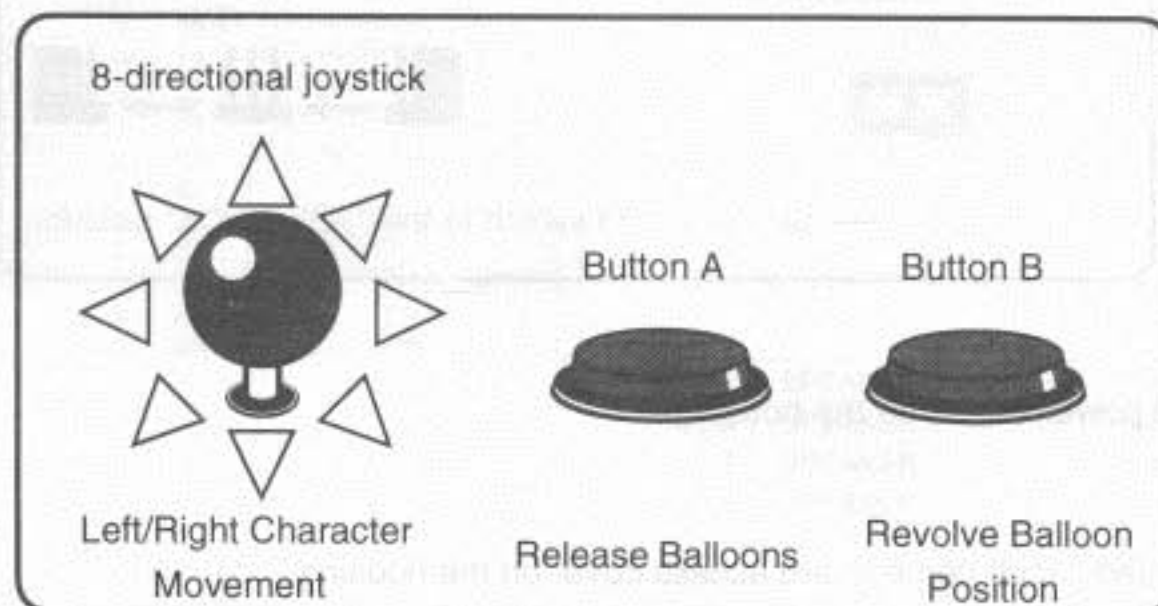

**[Device set up (setting up the input equipment)]**

- 1 Turn OFF the power switch on the housing

**Important**

- See the instruction manual for the specific housing to learn how the housing should be installed.

- 2 Open the printed circuit game board access cover on the housing.
- 3 Set switch JP3 on the F3 mother board.

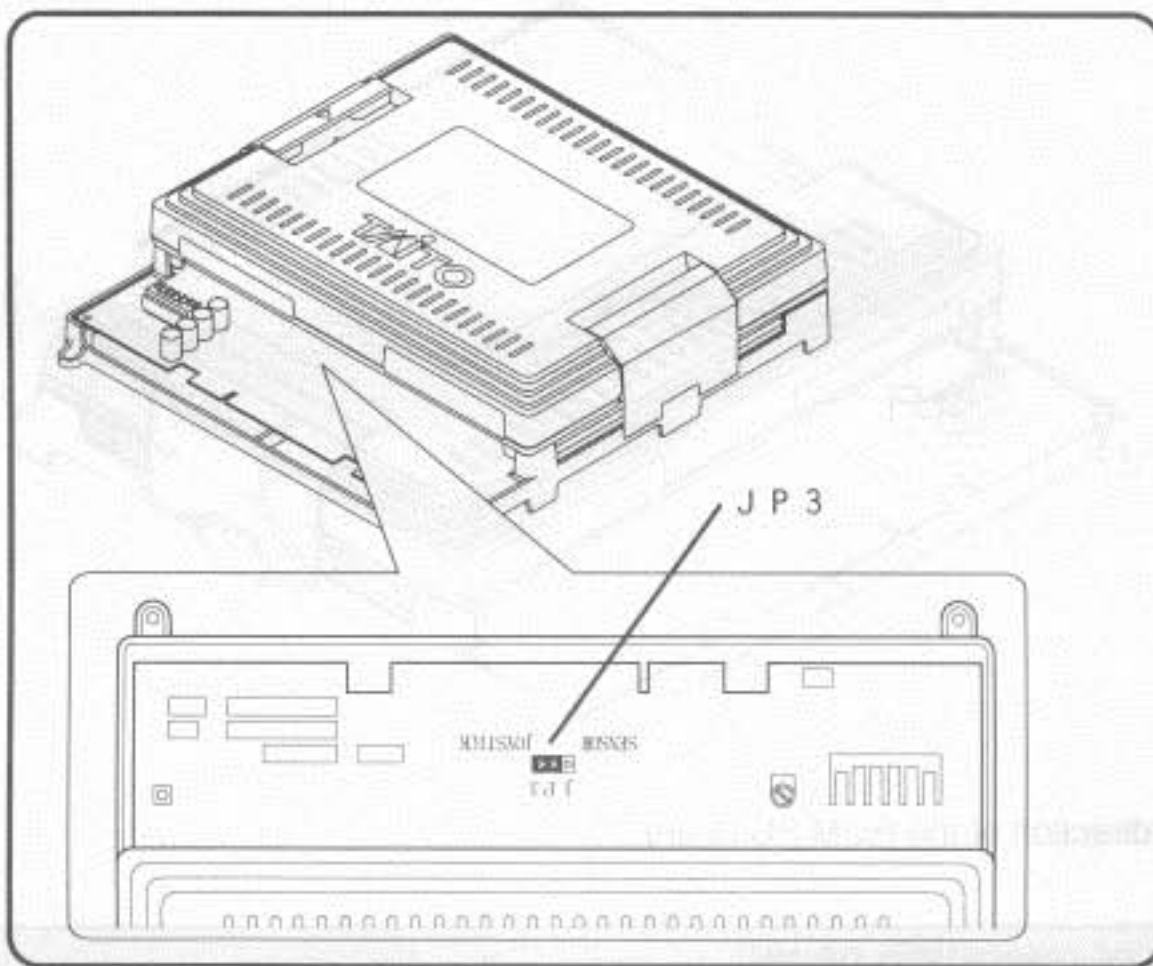

- Joystick: Set the JP3 switch to the "JOYSTICK" position.

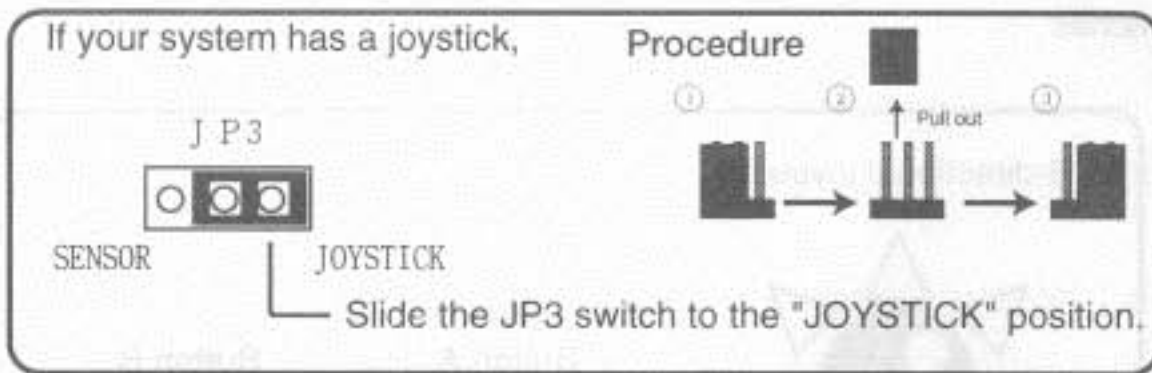

- 4 Turn OFF the power switch on the housing.
- 5 Close the printed circuit game board access cover on the housing.

**[Mother PC board]**

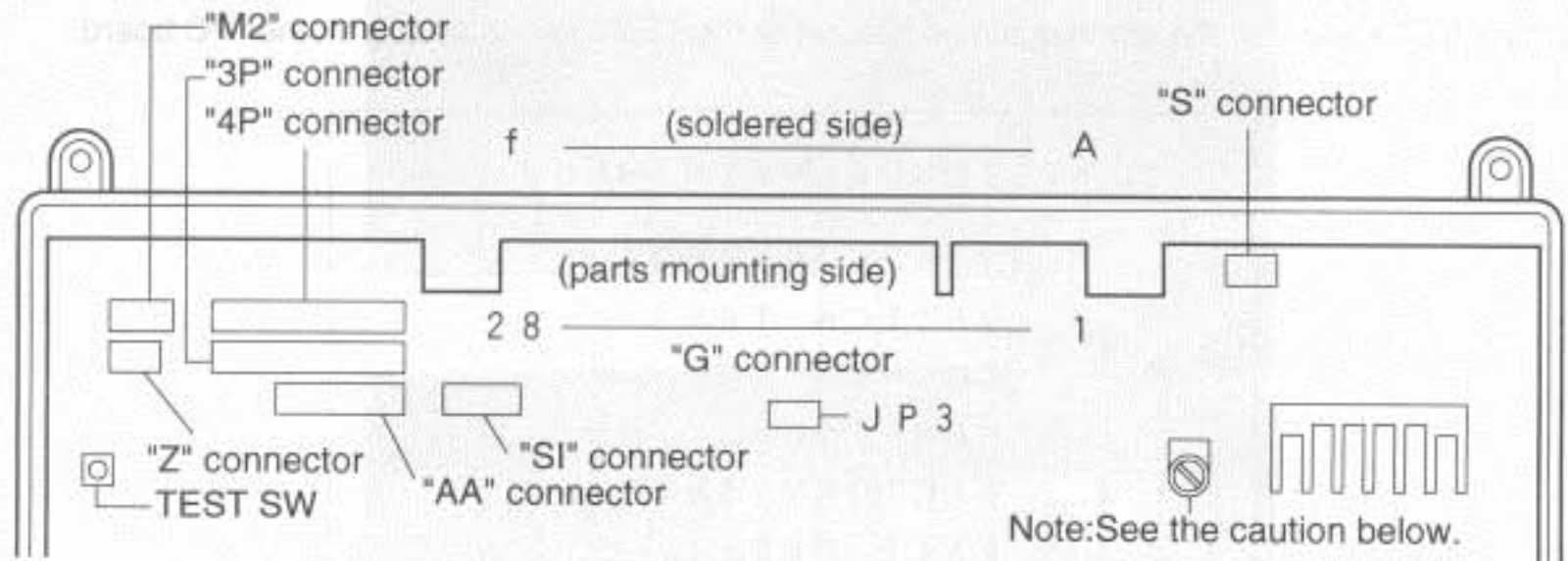

- This PC board has no dip switches. For selecting play fee and game contents, set at the test mode.

**\*Caution:**

- There is a dial on the PC board which is not for volume loudness adjustment. This dial is correctly adjusted at delivery. Never touch it.
- Set the JP3 to the "JOYSTICK" side.

**[Connector terminal list]**

G connector (JAMMA)			
Soldered side		Parts mounted side	
GND	A	1	GND
GND	B	2	GND
+5V	C	3	+5V
+5V	D	4	+5V
-5V	E	5	-5V
+12V	F	6	+12V
POST	H	7	POST
COIN COUNTER2	J	8	COIN COUNTER1
COIN LOCKOUT2	K	9	COIN LOCKOUT1
SPEAKER(-)	L	10	SPEAKER(+)
AUDIO(GND)	M	11	AUDIO(+)
VIDEO G	N	12	VIDEO RED
VIDEO SYNC	P	13	VIDEO BLUE
SERVICE SW	R	14	VIDEO GND
TILT	S	15	TEST SW
COIN SW2	T	16	COIN SW1
START SW2	U	17	START SW1
2P CONTROLLE1 UP	V	18	1P CONTROLLE1 UP
2P CONTROLLE2 DOWN	W	19	1P CONTROLLE2 DOWN
2P CONTROLLE3 LEFT	X	20	1P CONTROLLE3 LEFT
2P CONTROLLE4 RIGHT	Y	21	1P CONTROLLE4 RIGHT
2P CONTROLLE5 PUSH1	Z	22	1P CONTROLLE5 PUSH1
2P CONTROLLE6 PUSH2	a	23	1P CONTROLLE6 PUSH2
2P CONTROLLE7 PUSH3	b	24	1P CONTROLLE7 PUSH3
2P CONTROLLE8 SPARE	c	25	1P CONTROLLE8 SPARE
2P CONTROLLE9 SPARE	d	26	1P CONTROLLE9 SPARE
GND	e	27	GND
GND	f	28	GND

By connecting two speakers to the S connector as shown below, you can get realistic stereo sound.

"S" connector  
[In the case of applying a stereo system]

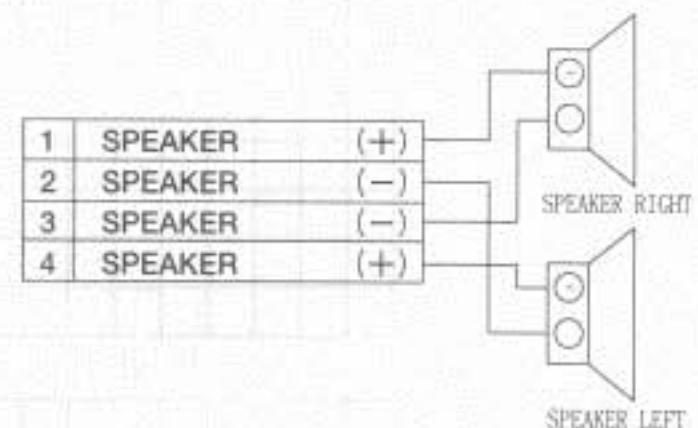

"S" connector  
[In the case of applying a monaural system]

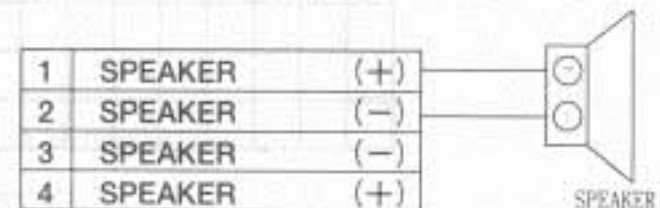

## [Test mode]

### [To enter test mode]

- Press the TEST switch on the game machine cabinet or the TEST switch on the mother PC board.

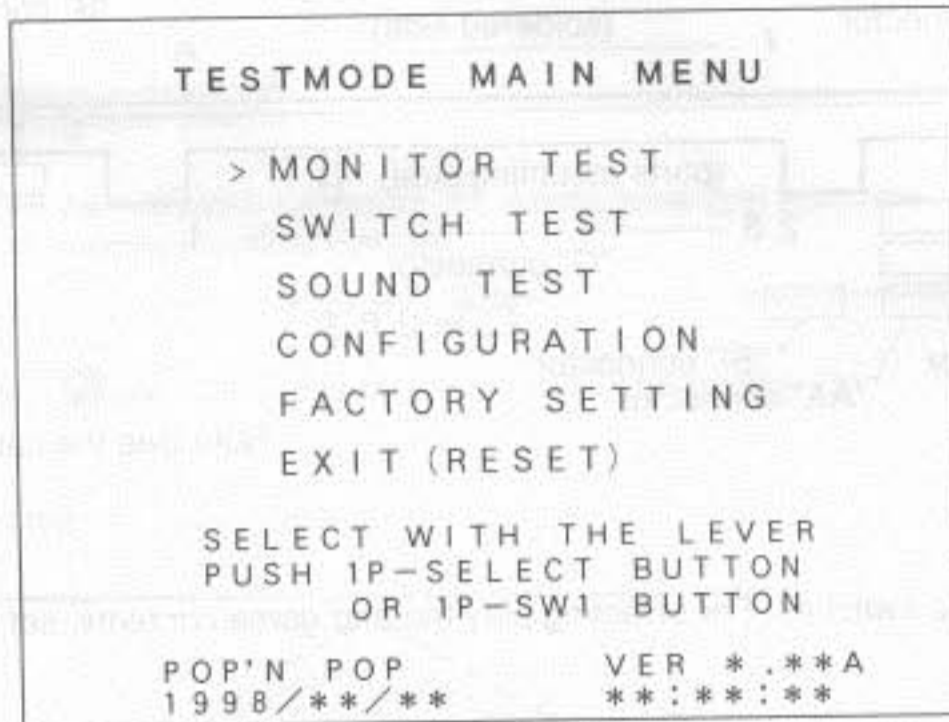

[Screen display]

- Move the cursor vertically by shifting the 1P side joystick up and down, and press the 1P side button A or select button. The machine initiates the test of the selected item.
- When you enter the test mode while having credits, the machine clears the credits.
- To end the Test mode, please select "EXIT(RESET)" and press the 1P side button A or select button.

### [Monitor test]

- Select [MONITOR TEST] item from test mode main menu and press the 1P side select button, a cross-hatch image appears. Check distortion of screen display image with this cross-hatch.

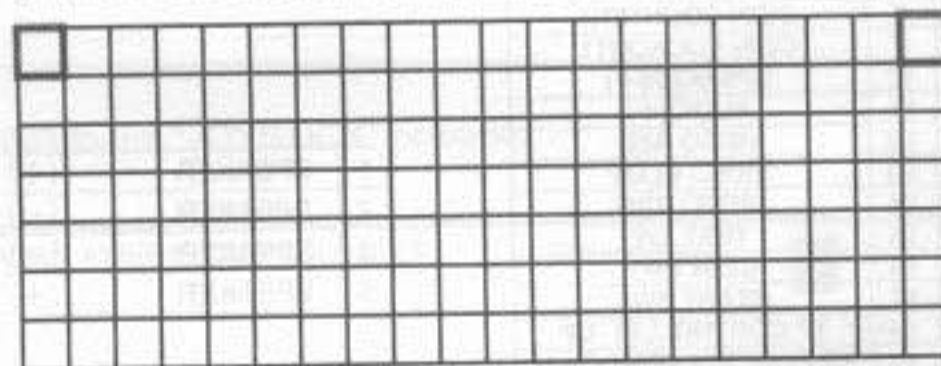

PUSH TEST SW RETURN TO MENU

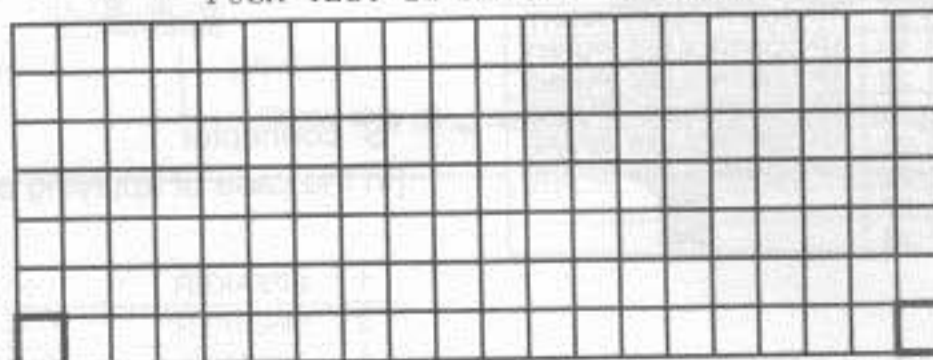

[Screen display]

- Each press of the 1P side select button changes display between cross-hatch and color bar. With color bar image, check color tone of the screen display.

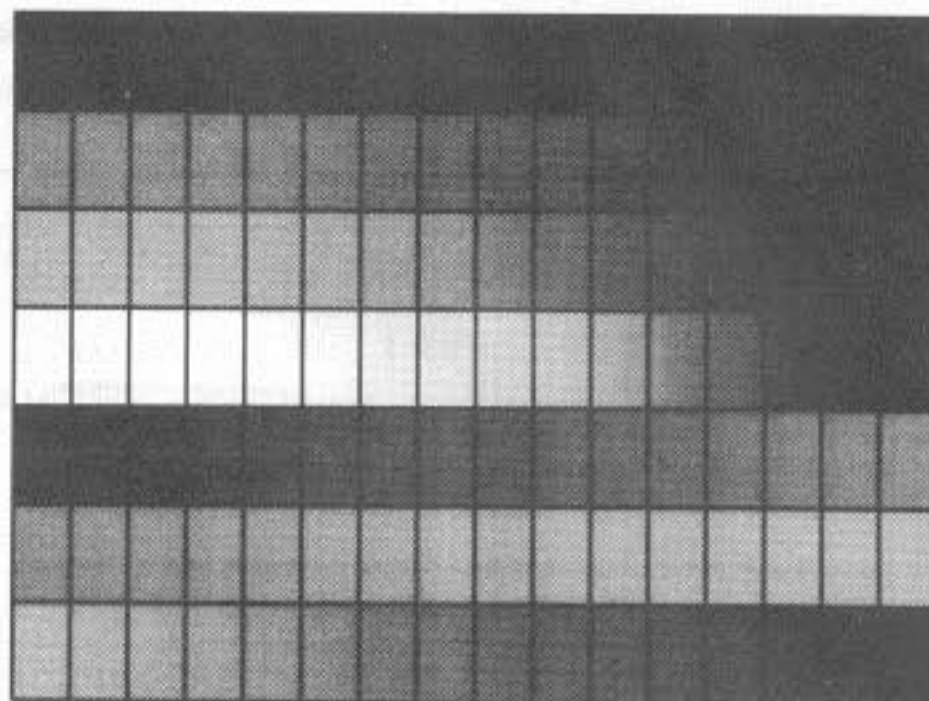

PUSH TEST SW RETURN TO MENU  
[Screen display]

- Press the TEST switch to return to main menu.

**[Switch test]**

- Select [SWITCH TEST] from test mode main menu and press the 1P side button A or select button. This test is to check input signal(function) of each switch.
- Press each switch one by one and if its corresponding indication on the screen changes from OFF to ON, its switch input is normal.

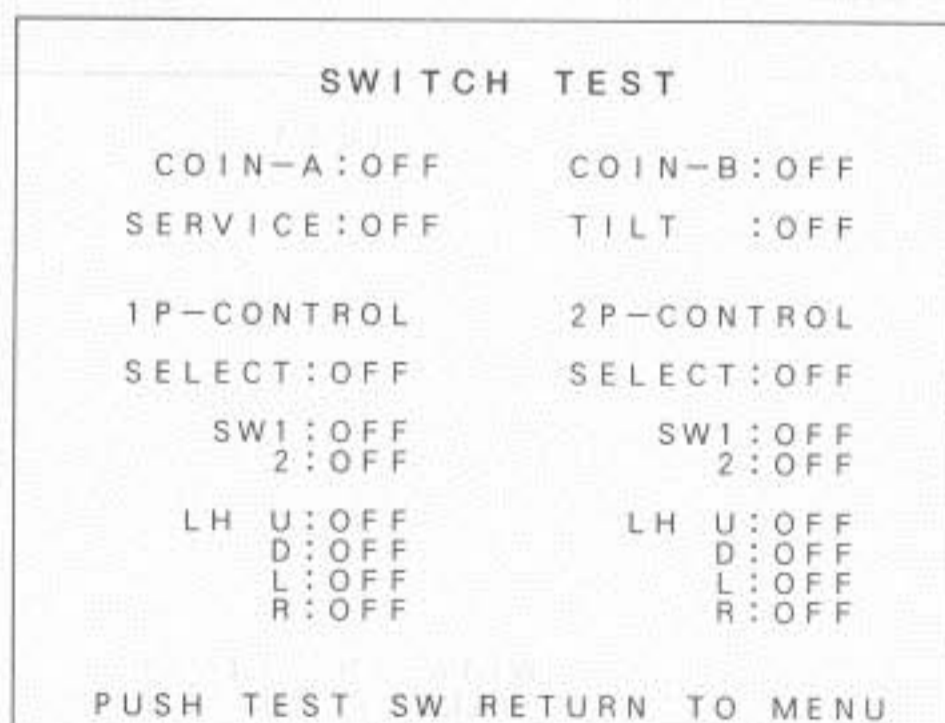

[Screen display]

- Press the TEST switch to return to main menu.
- "SW 1" and "SW 2" on this screen mean button A and button B, respectively.

### [Sound test]

- Select [SOUND TEST] item from test mode main menu, and press the 1P side button A or select button. This test is to adjust sound loudness of the game.
- Select an item by moving the player one(1P) side joystick up and down, and select the sound code and loudness by moving the same joystick left and right.

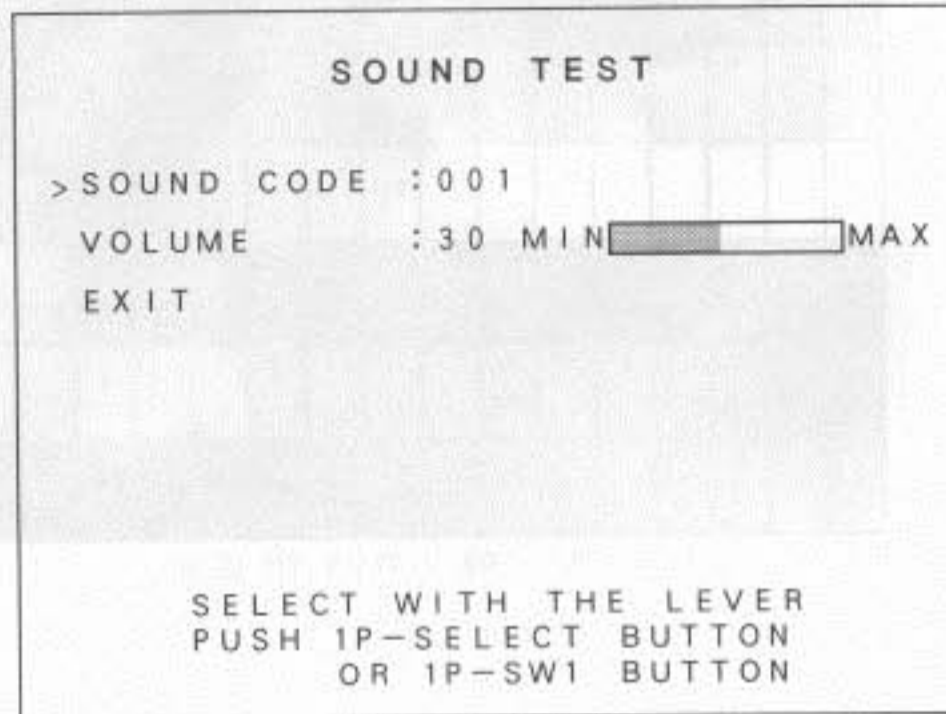

[Screen display]

### [To store changed contents of sound test]

- Select [EXIT] in [SOUND TEST], and press button A at the player one(1P) side. The screen shown below appears on the monitor.
- To save the change, select YES. Or if you don't want to save, select NO. (To select between YES and NO, move the joystick at the player one(1P) side left and right, and press button A at the player one(1P) side to determine selection.)

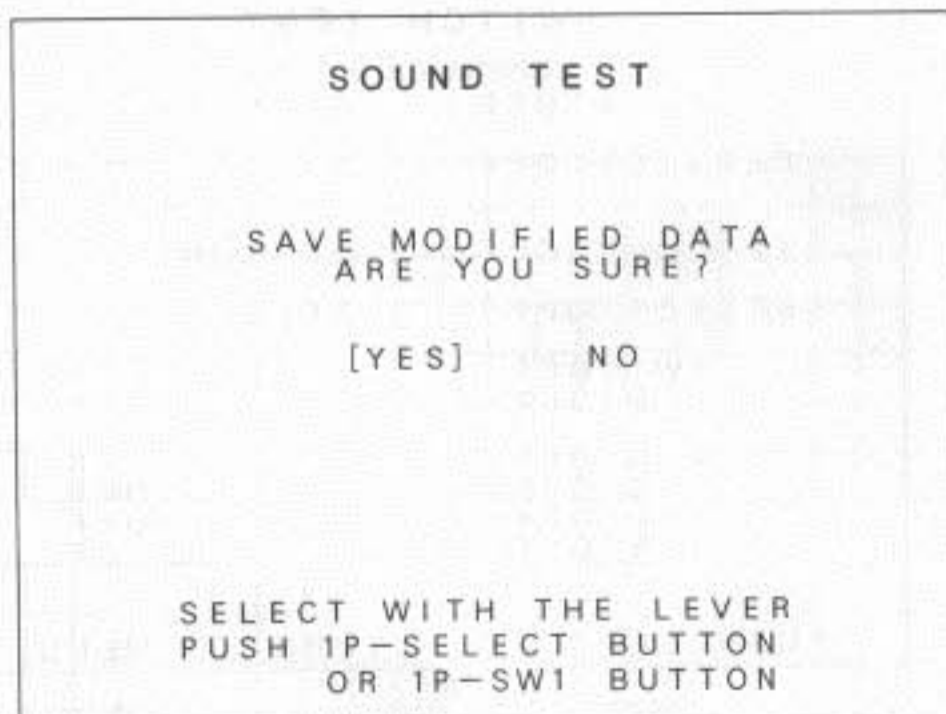

[Screen display]





**[Contents of configuration]**

**[COMMON SETTING]**

GAME STYLE	• D
	E
MONITOR	• NORMAL
	INVERT
ATTRACT SOUND	• WITH
	WITHOUT
DIFFICULTY	EASY
	• NORMAL
	HARD
	VERY HARD
CONTINUE PLAY	• WITH
	WITHOUT
VS ROUND	1
	• 3
	5

**[FOR NORTH AMERICA]**

COIN A	• 1COIN	• 1CREDIT
	2COINS	2CREDITS
	3COINS	3CREDITS
	4COINS	4CREDITS
		5CREDITS
		6CREDITS
BUY-IN PRICE	• SAME AS PLAY	
	1COIN	
	2COINS	
	3COINS	

**[EXCEPT NORTH AMERICA]**

COIN A	• 1COIN	• 1CREDIT
	2COINS	2CREDITS
	3COINS	3CREDITS
	4COINS	4CREDITS
		5CREDITS
		6CREDITS
COIN B	• 1COIN	1CREDIT
	2COINS	• 2CREDITS
	3COINS	3CREDITS
	4COINS	4CREDITS
		5CREDITS
		6CREDITS

• Factory setting

**[To save changed contents of configuration]**

- Select [EXIT] in [CONFIGURATION],and press button A at the player one(1P) side.  
The screen shown below appears on the monitor.
- To save the change,select YES. Or if you don't want to save,select NO.  
(To select between YES and NO,move the joystick at the player one(1P) side left and right,and press button A at the player one(1P) side to determine selection.)

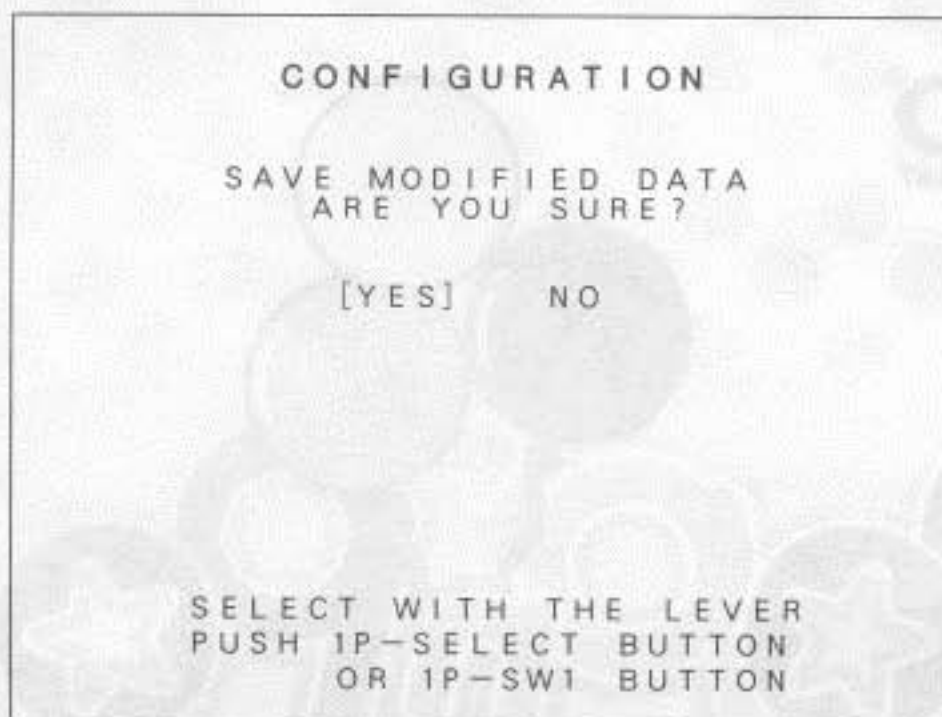

[Screen display]

**[Factory setting]**

- Select [FACTORY SETTING] from the test mode main menu,and press button A at the player one(1P) side,the screen shown below appears on the monitor.
- To revert all preset data to factory set values,select YES. Or if you don't want to revert,select NO.  
(To select between YES and NO,move the joystick at the player one(1P) side left and right,and press button A at the player one(1P) side to determine selection.)

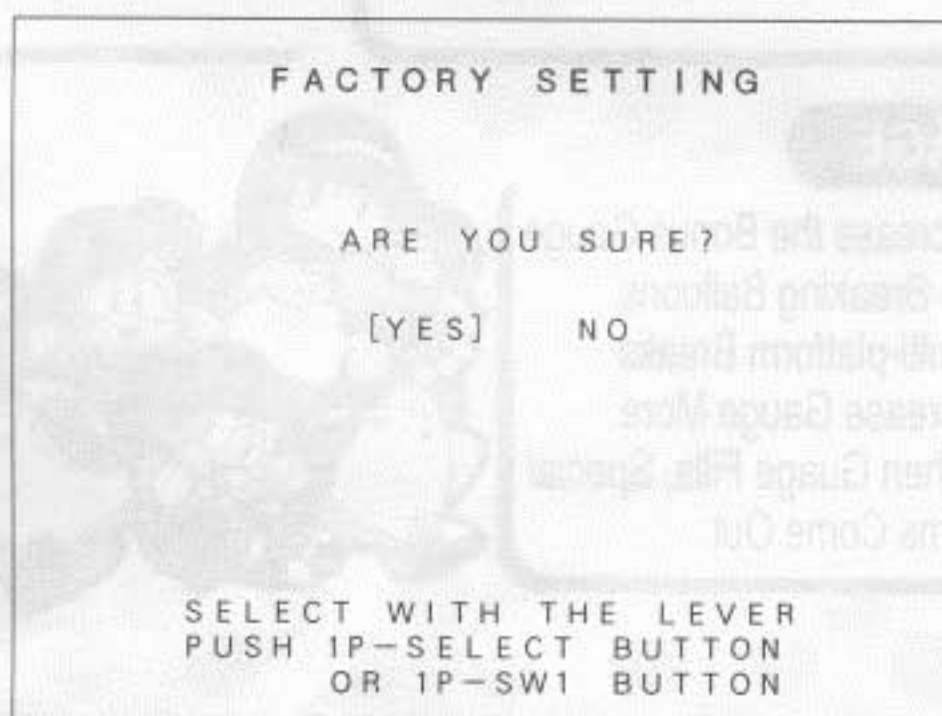

[Screen display]

**[Exit]**

- Select [EXIT] item from the test mode main menu,and press the 1P side button A or select button.  
The screen terminates test mode and returns to game mode.

**TAITO**<sup>®</sup>  
© TAITO CORP. 1997

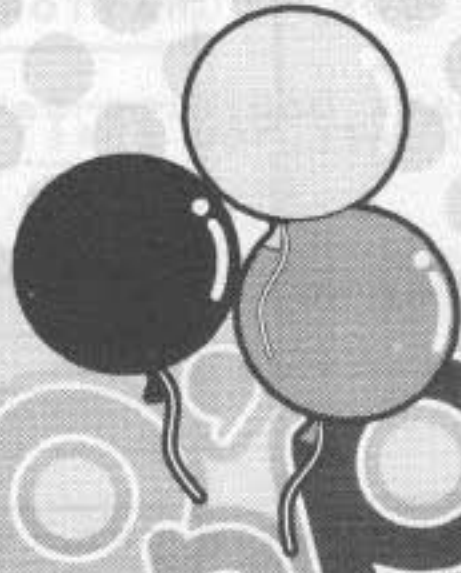

# Pop'n'Pop™

## HOW TO PLAY

3 or More of the Same Color Balloons Will Break the Balloons on the Cloud.  
The Stage Clears When Breaking All Balloons.  
Game Over If the Advancing Balloons Cross the End Line.

## PLAY INSTRUCTIONS

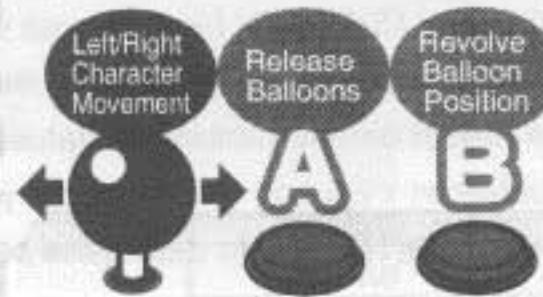

## ITEM GAUGE



Increase the Bonus Gauge by Breaking Balloons.  
Multi-platform Breaks Increase Gauge More.  
When Gauge Fills, Special Items Come Out.



G3500570A

TAITO



TAITO DELAYS



TAITO



**TAITO CORPORATION®**

©TAITO CORP. 1998 PRINTED IN JAPAN

### Connection of the mother PC board and ROM PC board

- (1) Match both triangle marks (shown below) of the mother PC board and ROM PC board. Then insert the connector.

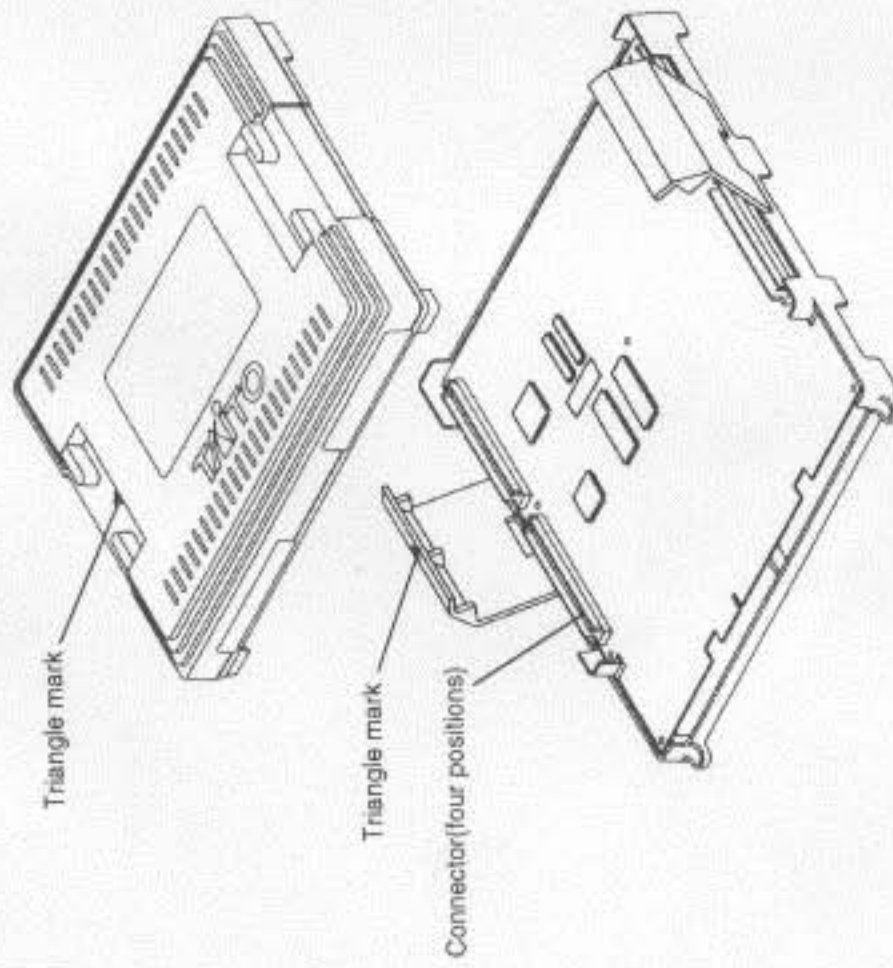

- (2) Set the ROM PC board on the mother PC board so that there is no gap at the four corners. (→)

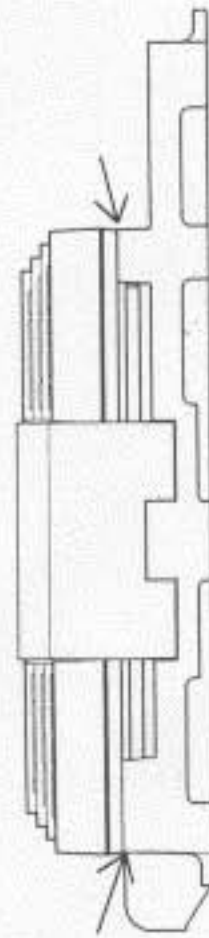

- (3) Lock the two fixing holders of the mother PC board on the ROM PC board. Each fixing holder has two tiny claws to lock onto the ROM PC board. Confirm that these claws are appropriately locked by hearing a "click" sound.

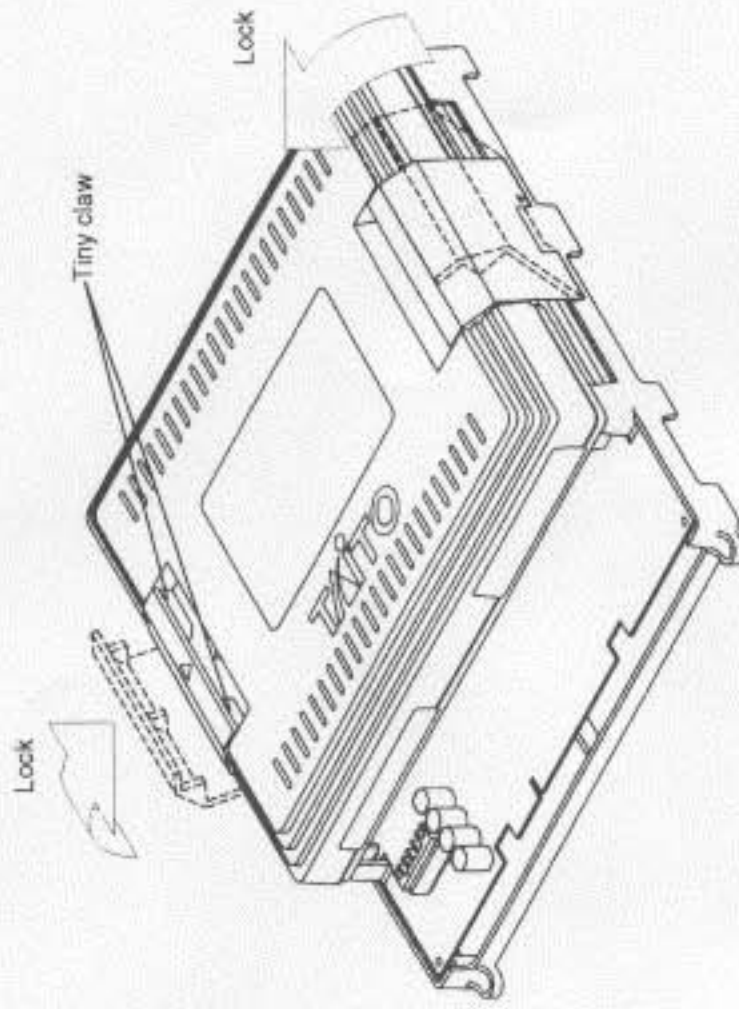

- (4) When taking of the ROM PC board from the mother PC board, follow the reverse procedure of item (1) to (3) above. However, when removing the fixing holders which are locking onto the ROM PC board, take out the claws one by one to release locking. Then follow the procedure of item (1) to (3) above.

## VORSICHTSMASSNAHMEN ZUR HANDHABUNG

Dieses Produkt beinhaltet Präzisionselektronik-Komponenten. Behandeln Sie diesen Behälter mit äußerster Sorgfalt.

1. Vermeiden Sie die Benutzung und Aufbewahrung dieses Behälters in der Nähe von Gegenständen oder Komponenten die eine hohe Wärmeabstrahlung haben.
2. Lassen Sie den Behälter nicht fallen und rütteln Sie nicht an ihm.
3. Halten Sie das Innere des Behälters trocken und frei von fremdartigen Gegenständen.
4. Blockieren Sie die Ventilatoren nicht.
5. Folgen Sie beim Austausch von Patronen den Beschreibungen in der Bedienungsanleitung.
6. Versuchen Sie nicht, die Patrone zu zerlegen, da sämtliche Garantien erlöschen, wenn die Patrone zerlegt und der Siegel nicht mehr unversehrt ist.

## PRECAUCIONES

Este producto contiene componentes electrónicos de precisión. Tenga mucho cuidado al manipular este recipiente.

1. Evite usar o almacenar la caja cerca de objetos o componentes de alta temperatura.
2. No deje caer ni sacuda el recipiente.
3. Mantenga el interior del recipiente libre de humedad y de materias extrañas.
4. No bloquee los ventiladores.
5. Para reemplazar el cartucho, siga el procedimiento descrito en el manual de instrucciones.
6. No intente desarmar el cartucho. Todas las garantías quedarán nulas si el cartucho es desarmado o si el sello es roto.

## 操作注意事項

本產品配有精密電子元件。操作和護理要格外小心。

1. 避免靠近高溫物體或零件使用或存放此盒。
2. 不可跌下或撞擊。
3. 保持盒內乾燥，無外來雜物。
4. 勿堵塞通風孔。
5. 換卡盒時須遵照使用說明書所述步驟操作。
6. 勿拆開卡盒。卡盒一經拆開或封條撕破，一切保用資格也隨着喪失和無效。

## PRECAUTIONS DE MANIPULATION

Ce produit contient des composants électroniques de précision. Faites particulièrement attention lorsque vous manipulez ce conteneur.

1. Evitez d'utiliser ou de ranger la boîte près d'objets ou de composants à hautes températures.
2. Ne pas laisser tomber ou secouer.
3. Préservez l'intérieur du conteneur de l'humidité et des corps étrangers.
4. Ne pas bloquer les ventilateurs.
5. Lors du remplacement des cartouches, suivez la procédure de fonctionnement du manuel d'instructions.
6. N'essayez pas de démonter la cartouche. Si elle est démontée ou si le scellement est cassé toutes les garanties seront nulles et sans effet.

## PRECAUZIONI SULL'USO

Questo prodotto contiene dei componenti elettronici ad alta precisione. Maneggiate quest'unità con molta attenzione.

1. Evitate di usare o riporre la custodia nelle vicinanze di oggetti o componenti che generano alte temperature.
2. Fate attenzione a non far cadere o esporre l'unità ad urti.
3. Assicuratevi di mantenere sempre la parte interna della custodia priva di umidità e di oggetti estranei.
4. Non bloccate i fori di ventilazione.
5. Alla sostituzione delle cartucce, seguite le istruzioni fornite nel manuale dell'unità.
6. Non cercate mai di smontare la cartuccia. Nel caso in cui venisse smontata oppure se il sigillo fosse spezzato, la garanzia non sarà più valida.

## 취급상의 주의

본 제품은 정밀한 전자부품으로 만들어져 있습니다. 다음과 같은 취급상의 주의 사항을 지켜 주시기 바랍니다.

1. 극단적으로 고온인 부품 가까이에서는 사용하지 마십시오.
2. 충격을 가하지 않도록 하여 주십시오.
3. 물이나 이물질이 들어가지 않도록 하여 주십시오.
4. 통풍 구멍이 막히지 않도록 하여 주십시오.
5. 카트리지를 교환할 때는 취급 설명서의 지시에 따라 주십시오.
6. 카트리지를 분해하지 마십시오. 만일 분해한 경우 또는 봉인 실(seal)을 파손시킨 경우, 수리 할 수 없습니다.

# TAITO®

G9500848A