

TM-083  
1st PRINTING

# Poolshark™

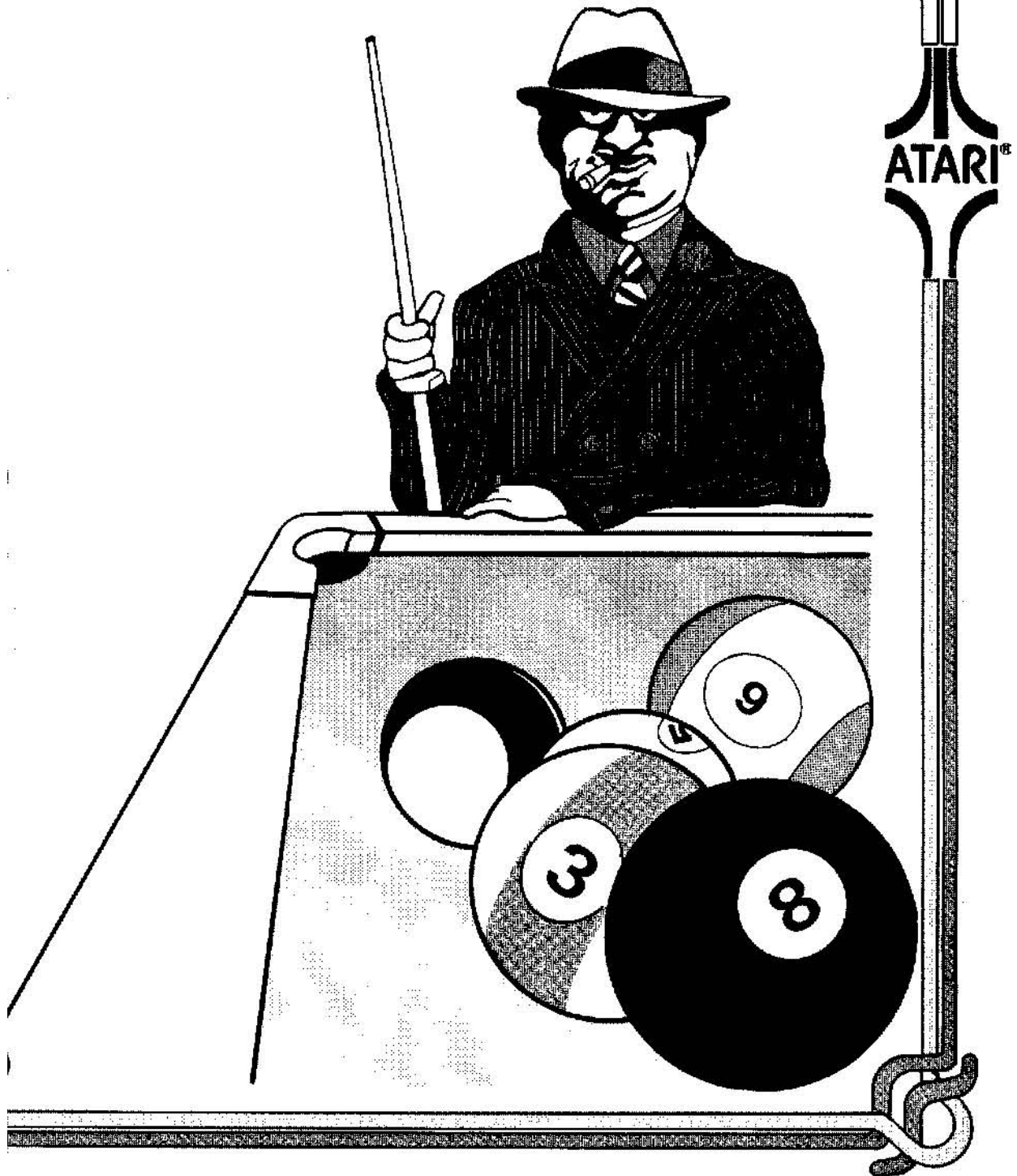

# Poolshark™

## Operation, Maintenance and Service Manual

ATARI INC  
1265 BORREGAS AVENUE  
SUNNYVALE, CALIFORNIA 94086  
408/745-2000 ■ TELEX 35-7488

By the Publications Group, Engineering Department

**ATARI®**

 A Warner Communications Company

# TABLE OF CONTENTS

<b>1 LOCATION SETUP</b>	
A. WHY YOU SHOULD READ THIS CHAPTER	1
B. GAME INSPECTION	2
C. INSTALLATION REQUIREMENTS FOR POOLSHARK	2
D. INTERLOCK AND POWER ON/OFF SWITCHES	2
E. SELF-TEST PROCEDURE IN TABLE 1	2
F. OPERATOR OPTIONS	7
<b>2 GAME PLAY</b>	
A. ATTRACT MODE	9
B. READY-TO-PLAY MODE	11
C. PLAY MODE	11
D. SELF-TEST MODE	11
<b>3 MAINTENANCE AND ADJUSTMENTS</b>	
A. CLEANING	14
B. COIN MECHANISM	14
Components on Coin Door	14
Access to Coin Mechanisms	14
Cleaning of Coin Paths	15
Adjustment of Coin Switch Trip Wire	15
Mechanical Adjustments of Coin Mechanism	16
General Troubleshooting Hints	16
C. ADJUSTMENTS ON TV MONITOR	16
D. TV MONITOR REMOVAL	18
E. FUSE REPLACEMENT	18
F. LAMP REPLACEMENT	18
G. START SWITCHES	19
H. JOYSTICKS	19
<b>4 THEORY OF OPERATION</b>	
A. POOLSHARK GAME OVERVIEW	23
B. POOLSHARK PCB OPERATION	23
Poolshark PCB Overview	
C. POOLSHARK PCB POWER	29
D. POOLSHARK MICROCOMPUTER	29
E. MICROCOMPUTER INTERFACE	29
Motion Circuit	29
Switch Distribution Circuit	30
Score/Playfield Circuit	30
Sound Circuits	31
Lamp Circuits	31
Joystick Circuits	31

# LIST OF ILLUSTRATIONS

Figure 1	Locations of On/Off, Interlock, and Self-Test Switches	3
Figure 2	Removal of Poolshark PCB and Location of Switches and Alignment Pots	8
Figure 3	Attract Mode TV Monitor Picture	10
Figure 4	Ready-to-Play Mode TV Monitor Picture	11
Figure 5	Play Mode TV Monitor Picture	11
Figure 6	Coin Door Assembly	14
Figure 7	Hinging Open the Magnet Gate Assembly	14
Figure 8	Removal of Coin Mechanism	15
Figure 9	Surfaces to Clean Inside the Coin Mechanism	15
Figure 10	Removal of Plate Covering Rear of Coin Slot	15
Figure 11	Close-Up View of Lubrication Point	16
Figure 12	Detail View of Coin Switch and Trip Wire	16
Figure 13	Adjustments on Coin Mechanism	17
Figure 14	Locations of Adjustments on TV Chassis	18
Figure 15	Removal of TV Monitor	19
Figure 16	Removal of Fluorescent Lamp	20
Figure 17	Harness Wire Connections on START Switches	21
Figure 18	Removal of Joysticks	21
Figure 19	Cleaning Potentiometers with Tuner Cleaner	22
Figure 20	Poolshark Game Block Diagram	24
Figure 21	Poolshark PCB Block Diagram	25
Figure 22	Poolshark Printed Circuit Board	26
Figure 23	Schematic Diagram (Sheets 1-6)	33
Figure 24	Oscilloscope Picture of $\theta 1$ , $\theta 2$ , and $\overline{CLOCK}$	47

# LIST OF TABLES

Table 1	Self-Test Procedure	4
Table 2	Optional Settings of Switch S1 on Poolshark PCB	8
Table 3	Aid for Locating Discrete Components in Figure 22	27
Table 4	Definitions of Schematic Signal Nomenclature	46

### **WHAT IS POOLSHARK?**

Poolshark™ is an Atari game that simulates the game of pocket pool, no pun intended, on a 23" TV monitor. This game has a self-test feature that tests approximately 75% of its internal circuitry. We hope the game earns you lots of money.

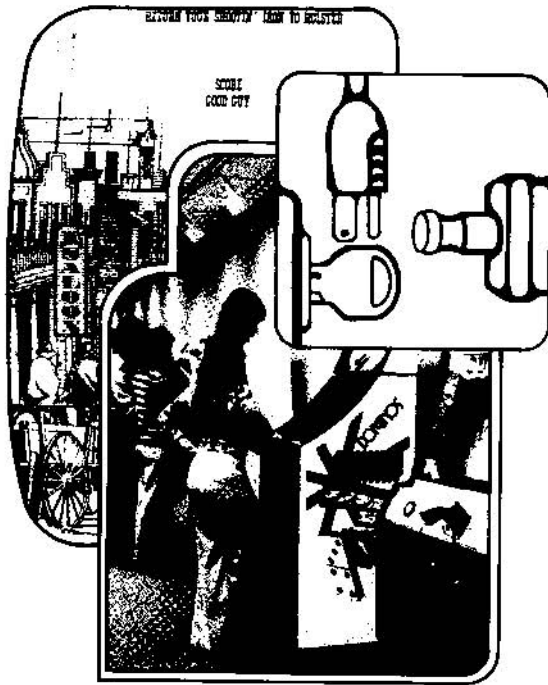

## LOCATION SETUP

### A. WHY YOU SHOULD READ THIS CHAPTER

Your new Poolshark™ is manufactured by Atari with the intent of being ready to play right out of the shipping carton. However, since we cannot be sure that the shipper delivered Poolshark to you in one piece, we need your cooperation in supplying the last touch of quality control. Therefore, we at Atari would appreciate your following the procedures of this chapter to ensure that you are getting the quality of game that you expect from Atari.

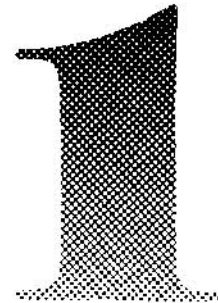

## **B. GAME INSPECTION**

**External Parts of Game Cabinet:** Check the outside of the game cabinet for dents, chips, or broken parts. If you have purchased this game as a new game, make sure that it looks new.

**Internal Parts of Game Cabinet:** Unlock and open the rear access door. Check the inside of the game cabinet for anything that looks out of place or broken.

## **C. INSTALLATION REQUIREMENTS FOR POOLSHARK**

All special requirements for the installation of Poolshark are listed as follows:

### **Power Requirements:**

Atari ships Poolshark for the domestic operation on 110 VAC, rated at approximately 150 watts. The game can be changed to operate at 95 VAC by unplugging the Molex connector plug with orange wires (110 VAC) and plugging on the Molex connector plug with black wires (95 VAC).

### **Temperature Range:**

Location and storage temperature ranges should be no lower than 0 degrees centigrade (32 degrees fahrenheit) to no higher than 49 degrees centigrade (120 degrees fahrenheit).

### **Humidity Range:**

Location and storage relative humidity should be no more than 80%.

### **Location Space Utilization:**

Poolshark requires a minimum of 166 centimeters (65.25 inches) of vertical clearance, a minimum of 64 centimeters (25.25 inches) of width clearance, and 135 centimeters (53 inches) of depth clearance. Depth clearance includes 61 centimeters (24 inches) of minimum player space.

### **Length and Type of Power Cord:**

Atari has added a 1.83-meter (six-foot) strain relief power cord to Poolshark. The advantage of the strain relief cord is that if someone trips over the cord, the cord will break off just inside the game. Someone tripping over a non-strain relief cord may result in ripping out the insides of a game.

## **D. INTERLOCK AND POWER ON/OFF SWITCHES**

Atari had two concerns that resulted in our installing two on/off switches, as illustrated in Figure 1. The first concern was to minimize the hazard of electrical shock while you are working inside the game cabinet. Therefore, we installed an interlock switch on the rear access door that completely removes power from the game when the rear access door is open.

Our second concern was energy conservation. A power on/off switch has been added to Poolshark so that the game can be turned off during low business periods and closing hours. This switch is conveniently hidden beneath the right-hand corner of the protruding section on the front of the game cabinet.

Please check for the proper operation of the rear access interlock switch by performing the following:

1. Unlock and open the rear access door.
2. Plug the AC power cord into a 110-volt source.
3. Set the power on/off switch to the *on* position by flipping the toggle switch toward the front of the game cabinet.
4. Close the rear access door. Within approximately thirty seconds, the TV monitor should display a picture.
5. Slowly open the rear access door until the TV monitor picture disappears. The TV monitor picture should disappear when the rear access door is opened to less than one-inch at the top of the door.
6. Close and lock the rear access door. If the results of Step 5 are OK, then the interlock switch is operating properly. If not OK, check to see if switch is broken from its mounting or stuck in the *on* position.

## **E. SELF-TEST PROCEDURE IN TABLE 1**

Poolshark will test itself and provide data to communicate with you that the game's circuitry and controls are or are not operating properly. We suggest that you do the Poolshark Self-Test Procedure each time you collect the money from the game. All you need to do is follow Table 1. But first, please read the following explanation of the table.

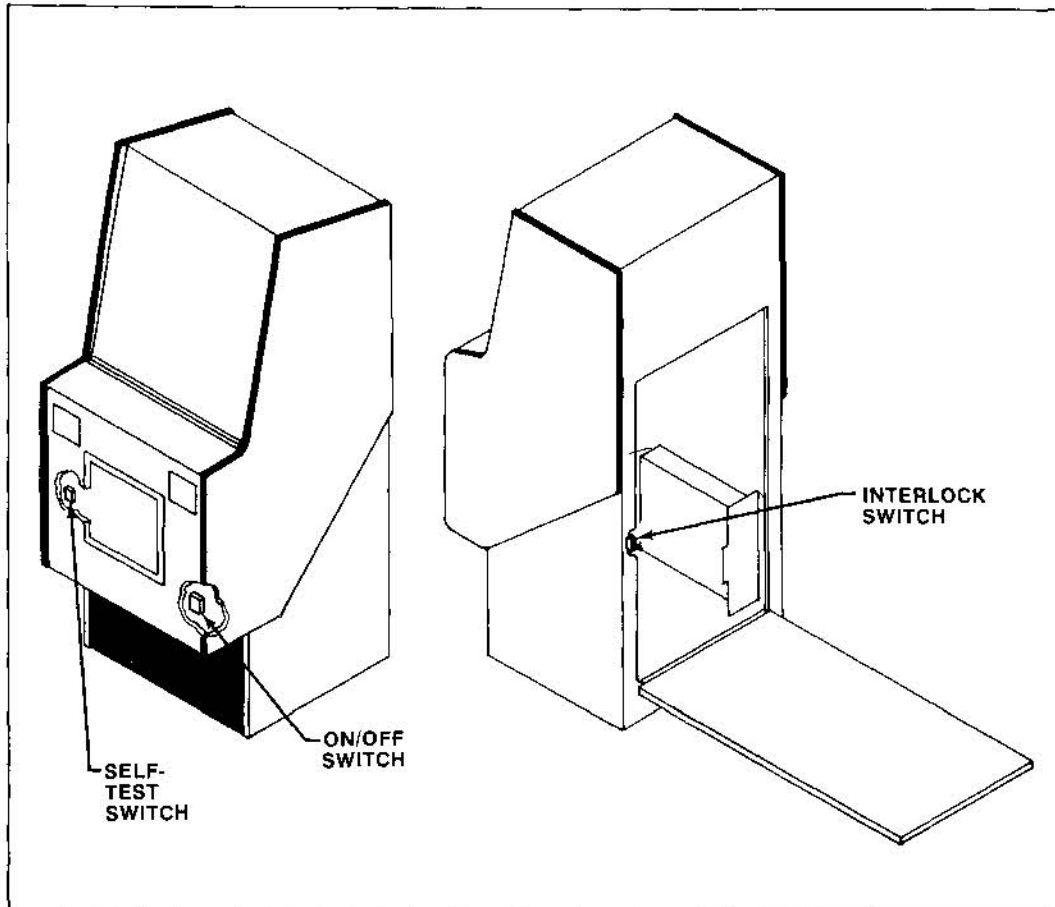

Figure 1 Locations of On/Off, Interlock, and Self-Test Switches



Notice the three column headings of Table 1. The first column, *Operator Action*, describes what you should do to make Poolshark test itself. Once you have performed each Operator Action Step, look at the picture on the Poolshark TV monitor and match that picture with the picture in the column labeled Poolshark TV Monitor Picture. Then, read the definition of that picture and follow the instructions listed in the column labeled *Definition of TV Monitor Picture*. Please note that Step 1's third column is quite long. Refer to Figure 1 for location of the self-test switch.

If at any time you would like to start over again in the self-test mode, just set the self-test switch to *off*, then again to the *on* position. This will begin the self-test mode at Step 1.

1. Unlock and remove rear access door.
2. Locate RF shield in lower right-hand corner.
3. Remove five #6 x 1/2-inch small pan-head Phillips screws from each of the long sides (total ten) of the R.F. Box Assembly.



Table 1 Self-Test Procedure

Operator Action	POOLSHARK TV Monitor Picture	Definition of TV Monitor Picture																					
<p>Note: Poolshark will not go into the self-test mode if there is game credit or if the game is in the play mode.</p> <p><b>Step 1</b> Set self-test switch to on position. Refer to Figure 1 for location of self-test switch.</p>		<p>Test OK— Indicates that computer memory of Poolshark is operating properly.</p> <p>POT P1 ALIGNED— Indicates that left player's cue ball joystick x axis (left/right direction) circuit is properly adjusted.</p> <p>PUSH START 2— Indicates that you should continue self-test, as stated in Operator Action Step 2.</p>																					
	 <p>or TEST B or TEST C or TEST D or TEST E or TEST F</p>	<p>TEST A or TEST B or TEST C or TEST D or TEST E or TEST F</p> <p>Indicates that the computer memory of Poolshark is failing. If this test failure occurs, we suggest that you note the failure and immediately contact your distributor. To solve this problem, you will need special replacement parts, available only through your distributor. The following is a list of failing circuits that relate to the failure indication of the Poolshark picture.</p> <table border="1" data-bbox="906 1087 1170 1276"> <thead> <tr> <th>Test Failure</th> <th>IC for -01 Poolshark PCB</th> <th>IC for -02 Poolshark PCB</th> </tr> </thead> <tbody> <tr> <td>TEST A</td> <td>P1</td> <td>P1</td> </tr> <tr> <td>TEST B</td> <td>N1</td> <td>N1</td> </tr> <tr> <td>TEST C</td> <td>A1 and/or E1</td> <td>K1</td> </tr> <tr> <td>TEST D</td> <td>B1 and/or F1</td> <td>X1</td> </tr> <tr> <td>TEST E</td> <td>C1 and/or H1</td> <td>L1</td> </tr> <tr> <td>TEST F</td> <td>D1 and/or J1</td> <td>L1</td> </tr> </tbody> </table>	Test Failure	IC for -01 Poolshark PCB	IC for -02 Poolshark PCB	TEST A	P1	P1	TEST B	N1	N1	TEST C	A1 and/or E1	K1	TEST D	B1 and/or F1	X1	TEST E	C1 and/or H1	L1	TEST F	D1 and/or J1	L1
	Test Failure	IC for -01 Poolshark PCB	IC for -02 Poolshark PCB																				
TEST A	P1	P1																					
TEST B	N1	N1																					
TEST C	A1 and/or E1	K1																					
TEST D	B1 and/or F1	X1																					
TEST E	C1 and/or H1	L1																					
TEST F	D1 and/or J1	L1																					
	<p>POT P1 NOT ALIGNED—</p> <p>Indicates that left player's joystick x axis (left/right direction) circuit is not properly adjusted. During game play, this problem will cause the cue ball to move without the player's command. Before doing anything, tap the left player's cue ball joystick. If TV monitor picture changes to POT P1 ALIGNED PUSH START 2 alignment of POT P1 is OK. However, it is best to determine if the springs of the joystick are worn. To do so, apply sideways pressure in one direction, then the other, to the joystick. You should feel an obvious center position to the joystick. The joystick should snap to its center</p>																						

**Table 1 Self-Test Procedure**



Operator Action	POOLSHARK TV Monitor Picture	Definition of TV Monitor Picture
		<p>position if moved in one direction and then let loose. If this obvious center position does not exist, call your distributor and arrange for the installation of a new joystick.</p> <p>If there is an obvious center position and the TV monitor picture still indicates POT P1 NOT ALIGNED you need to remove the Poolshark PCB and adjust potentiometer P1.</p> <p>NOTE: One of the major expenses of Poolshark is the PCB. If you do not have electronic hardware training, do <i>not</i> attempt to remove the PCB. Instead, contact your distributor. The mistake you make may cost you a good deal of money from downtime and repair costs.</p> <p>Refer to Figure 2 for detailed information for the removal of Poolshark PCB and the location of POT P1, POT P2, POT P3, and POT P4.</p>
<p><b>Step 2</b> Press right player's START pushbutton.</p>		<p>POT P2 ALIGNED— Indicates that left player's cue ball joystick y axis (up/down direction) circuit is properly aligned.</p> <p>PUSH START 2—Indicates that you should continue self-test, as stated in Operator Action Step 3.</p>
		<p>POT P2 NOT ALIGNED— Indicates that left player's joystick y axis (up/down direction) circuit is not adjusted properly. Refer to previous instructions for POT P1 NOT ALIGNED. Remember that you are working with the up/down motion of the left player's joystick.</p>
<p><b>Step 3</b> Press right player's START pushbutton.</p>		<p>POT P3 ALIGNED— Indicates that right player's cue ball joystick x axis (left/right direction) circuit is operating properly.</p> <p>PUSH START 2—Indicates that you should continue self-test, as stated in Operator Action Step 4.</p>

Table 1 Self-Test Procedure







Operator Action	POOLSHARK TV Monitor Picture	Definition of TV Monitor Picture
		<p>POT P3 NOT ALIGNED—</p> <p>Indicates that right player's joystick x axis (left/right direction) circuit is not properly adjusted. Refer to previous instructions for POT P1 NOT ALIGNED. Remember that you are working with the left/right motion of the right player's joystick.</p>
<p><b>Step 4</b> Press right player's START pushbutton.</p>		<p>POT P4 ALIGNED—</p> <p>Indicates that right player's cue ball joystick y axis (up/down direction) circuit is properly aligned.</p>
		<p>PUSH START 2—</p> <p>Indicates that you should continue self-test, as stated in Operator Action Step 5.</p> <p>POT P4 NOT ALIGNED—</p> <p>Indicates that right player's joystick y axis (up/down direction) circuit is not adjusted properly. Refer to previous instructions for POT P1 NOT ALIGNED. Remember that you are working with the up/down motion of the right player's joystick.</p>
<p><b>Step 5</b> Press right player's START pushbutton.</p>		<p>TEST COMPLETE—</p> <p>Indicates Poolshark has completed the video tests. Proceed with the switch tests in Steps 6 through 9.</p>
<p><b>Step 6</b> Press and momentarily hold left player's START pushbutton, then listen for sound that rapidly goes from a low to a high frequency.</p>		<p>Audio sound indicates D-A LATCH circuit is operating properly.</p>
<p><b>Step 7</b> Press and momentarily hold right player's START pushbutton, then listen for sound described in Step 6.</p>		<p>Audio sound indicates D-A LATCH circuit is operating properly.</p>

Table 1 Self-Test Procedure

Operator Action	POOLSHARK TV Monitor Picture	Definition of TV Monitor Picture
<p><b>Step 8</b> Press and momentarily hold left coin acceptor trip wire, then listen for sound described in Step 6.</p>		<p>Audio sound indicated D-A LATCH circuit is operating properly.</p>
<p><b>Step 9</b> Press and momentarily hold right coin acceptor trip wire, then listen for sound described in Step 6. This completes the test and Poolshark is now ready to earn money. Set the self-test switch to the <i>off</i> position.</p>		<p>Audio sound indicates D-A LATCH circuit is operating properly.</p>

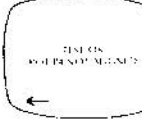
4. Slip Poolshark PCB out of R.F. Box Assembly.
5. Ensure that the PCB is not touching metal sides of R.F. Box Assembly.

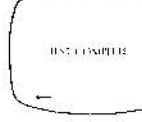
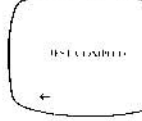
**CAUTION**

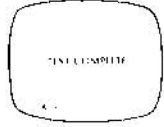
Placing rear access interlock switch plunger in the defeat position results in the application of 110 VAC to Poolshark. Use extreme caution to prevent the hazard of electrical shock while working inside the game cabinet.

6. Defeat rear access interlock switch by pulling out on white switch plunger.
7. If alignment potentiometers were adjusted, set self-test switch to *off*, then back to *on* position. Recheck alignment of Steps 1 through 4 of Table 1.
8. Push the rear access interlock switch out of defeat position, then reinstall Poolshark PCB.
9. Close and lock rear access door.

**F. OPERATOR OPTIONS**

At this time, it is best to select the game options best suited for your particular location. With the self-test switch set to the *off* position and Poolshark in the attract mode (no game credit), Poolshark may be set for the combinations of options you choose.

To set these options, refer to Figure 2 and remove Poolshark PCB. While the PCB is removed, determine if you would like to have extended play. Extended play works like this: if a player puts all the balls into the pockets within the thirty-second rack time, extended play will give him a new rack and fifteen seconds more time. Without extended play, after the player puts all the balls into the pockets, he gets a new rack. The player continues playing on the time of the rack during which all the balls were dropped. Extended play is selected by setting Toggle 1 of Switch S3 to the *on* or "+" position. Set toggles of Switch S1 to your choosing as determined from Table 2 as follows:

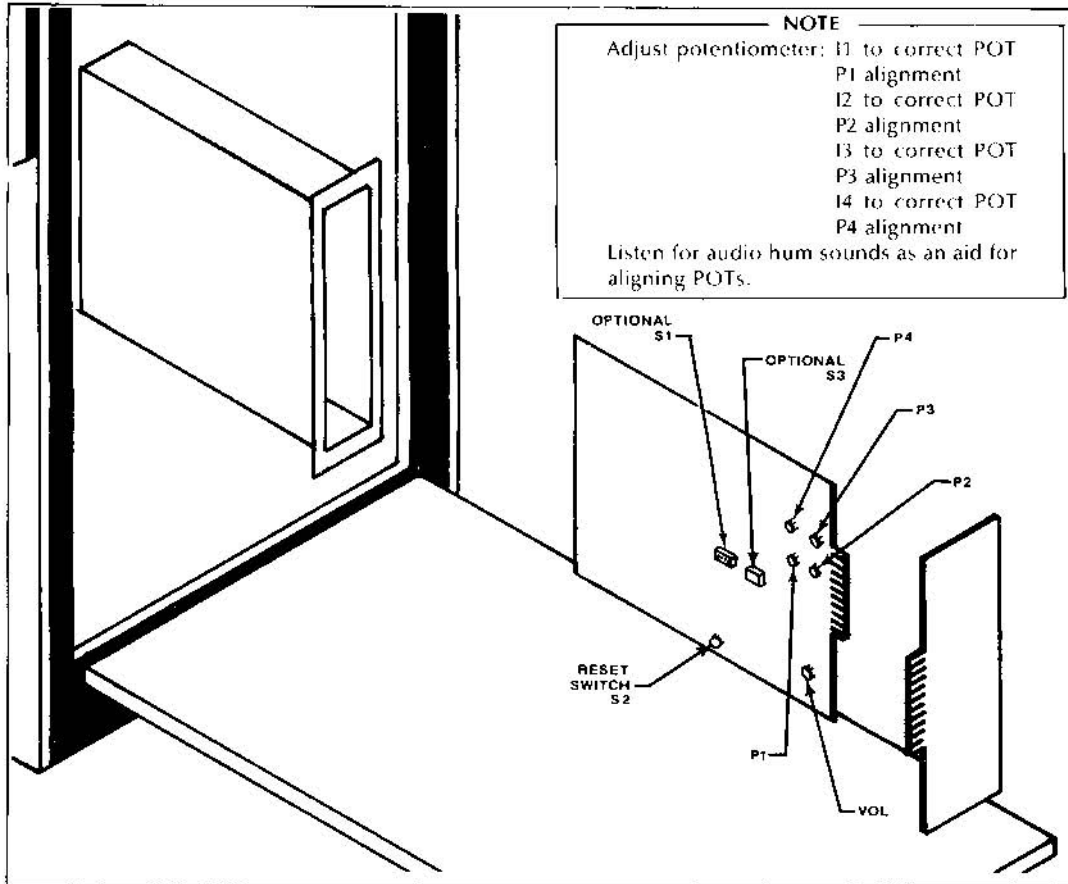

Figure 2 Removal of Poolshark PCB and Location of Switches and Alignment Pots

Table 2 Optional Settings of Switch S1 on Poolshark PCB

Switch S1 Toggle No.				Video Picture of Racks Per Game	Video Picture of Coins Per Game
1	2	3	4		
OFF	OFF				1 COIN EACH
OFF	ON				1 COIN 1 GAME
ON	OFF				1 COIN 2 GAMES
ON	ON				2 COINS EACH
		OFF	OFF	2 RACK GAME	
		OFF	ON	3 RACK GAML	
		ON	OFF	4 RACK GAME	
		ON	ON	5 RACK GAME	

Note: The on position for Switch S1 is toward IC location J5.



## GAME PLAY

During use, Poolshark can be described as operating in four modes: attract, ready-to-play, play, or self-test.

### A. ATTRACT MODE

The attract mode begins with the application of power. During this mode, the TV monitor picture, as illustrated in Figure 3, shows a pool table set with a rack of balls and a cue ball. The TV monitor picture also shows the number of coins necessary for a game and the number of racks per game.

The only controls the game will respond to during this mode are the coin mechanism coin acceptors and the self-test switch. Depositing the proper number of coins (as shown on the TV monitor picture) will cause the game to change to the ready-to-play mode. Setting the self-test switch to the *on* position will cause the game to change to the self-test mode. There is no sound during this mode.



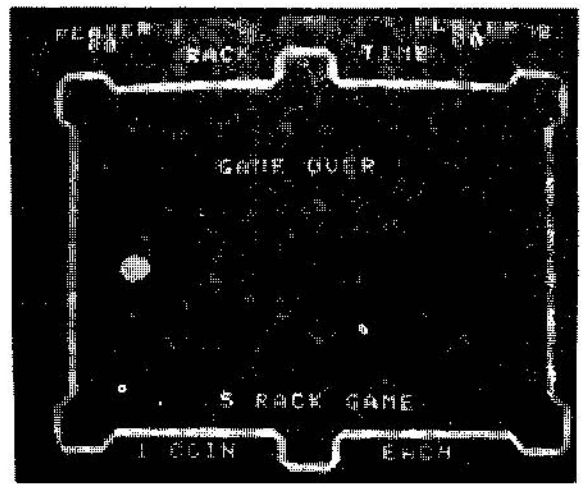
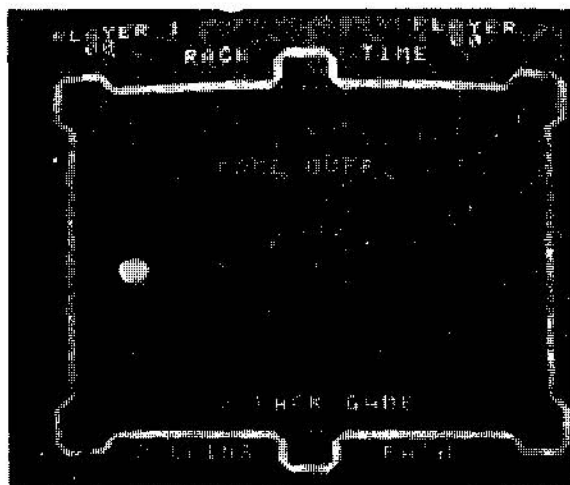
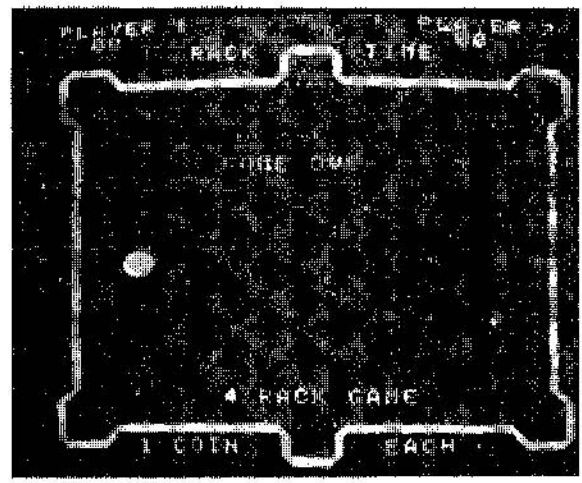
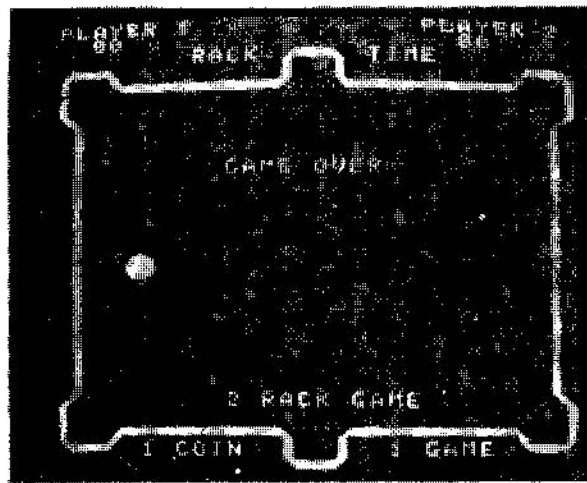
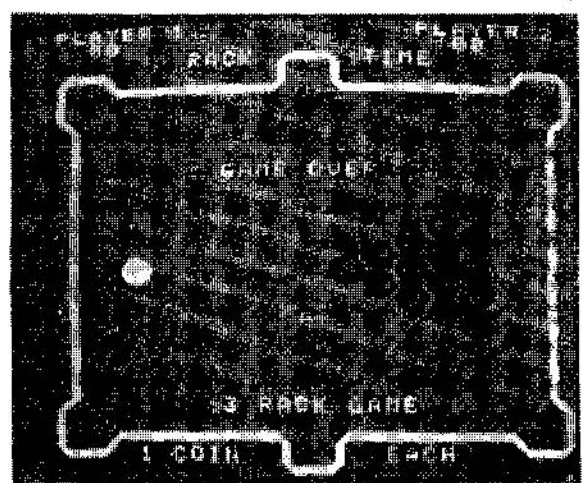
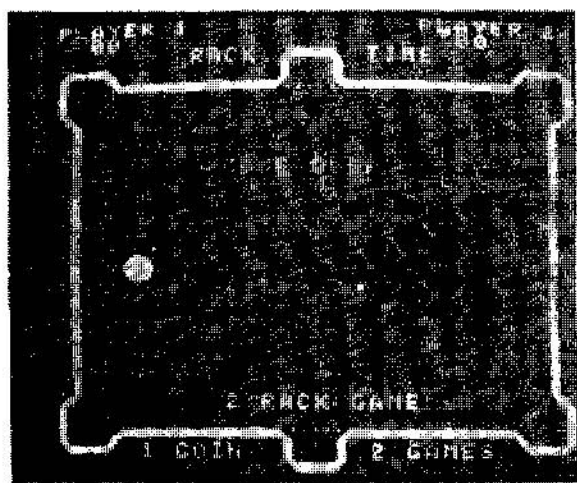

## B. READY-TO-PLAY MODE

The ready-to-play mode begins with the depositing of the necessary coins as indicated in the attract mode. During this mode, the TV monitor picture, as illustrated in Figure 4, "tells" the player or players which START pushbutton to push. This statement replaces the GAME OVER statement of the attract mode. Otherwise the TV monitor picture of this mode is exactly the same as the attract mode.



Figure 4 Ready-To-Play Mode TV Monitor Picture

Once the game enters this mode, it will not react to any controls other than the START pushbuttons. Pushing the appropriate START pushbutton will cause the game to change to the play mode. There is no sound during this mode.

## C. PLAY MODE

The play mode begins with a player pushing one of the two START pushbuttons. During this mode, the TV monitor picture, as illustrated in Figure 5, "tells" the player or players which joystick is presently active (arrow at bottom of picture points towards active joystick), how much time is left in the rack, and each player's score.

During this mode the coin acceptors will not accept any coins, the START pushbuttons are inactive (after being pushed to enter this mode), and the self-test switch has no effect. The sounds of this mode are "bump" when the balls strike the bumper boundary of the pool table, "score" when a ball drops into a pocket, "click" when a ball hits another ball, and "scratch" sound when the cue ball drops into a pocket.

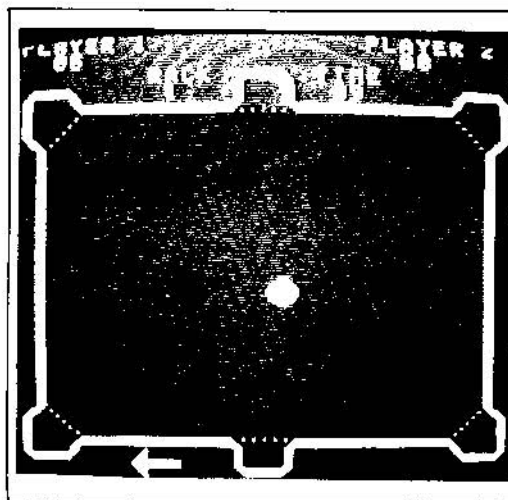

Figure 5 Play Mode TV Monitor Picture

## D. SELF-TEST MODE

The self-test mode begins with the setting of the self-test switch to the on position. During this mode, the TV monitor pictures, as illustrated in Table 2 of Chapter 1, provide data to communicate with the operator that the game's circuitry and controls are or are not operating properly. This mode can only be entered from the attract mode.

Once this mode is entered, Poolshark's self-test must be continued by the operator. This is done by you, the operator, pushing the START 2 pushbutton. At the end of the self-test procedure, the operator then has the responsibility of listening for a sound (same sound used for "score", as mentioned in Play Mode) while pressing the START pushbuttons and tripping the coin acceptors.



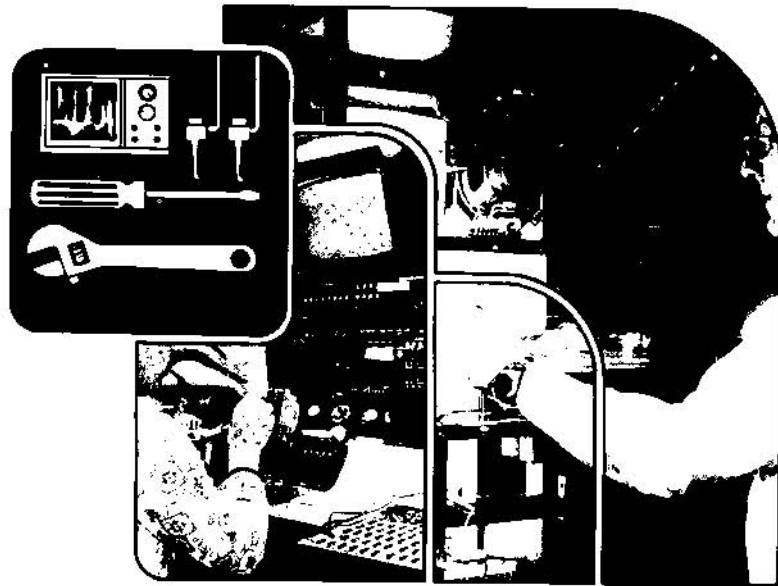

## MAINTENANCE AND ADJUSTMENTS

Due to its solid-state electronic circuitry, this Atari game should require very little maintenance and only occasional adjustment. Information given in this chapter and elsewhere in the manual is intended to cover most servicing situations that may be encountered at the game site. The procedures given are in sufficient detail to be understood by a person with moderate technical ability.

### NOTE

*If reading through the manual does not lead to solving the specific maintenance problem, you can reach Atari's Customer Service Department by telephone (open Monday through Friday, 7:30 am to 4:30 pm Pacific Standard Time):*

*from outside California (800) 538-6892  
(toll-free)*

*from inside California (408) 984-1900*

*For those interested in gaining more information on video game technology, especially the electronics, we recommend reading the **Video Game Operator's Handbook**, manual no. TM-043. This book is available from Atari, Inc., attn. Customer Service Dept., 2175 Martin Avenue, Santa Clara, CA 95050 for \$5.00 each, or from your distributor.*



## A. CLEANING

The exteriors of game cabinets and plex panels may be cleaned with any non-abrasive household cleaner. If desired, special coin machine cleaners that leave no residue can be obtained from distributors. Do *not* dry-wipe the plex panels because any dust on the surface can scratch the surface and results in fogging the plastic.

## B. COIN MECHANISM

### Components On Coin Door

Figure 6 shows the back side of the coin door assembly where the game's two coin mechanisms are mounted. Included is the lock-out coil assembly; the lock-out wires are connected to this assembly but are hidden behind the coin mechs. During the attract mode the microcomputer energizes the lock-out coil, causing the lock-out wires to retract far enough to allow genuine coins to reach the coin box. But during the ready-to-play mode when the LED is lighted and during the play mode (and also when AC power to the game has been turned off)

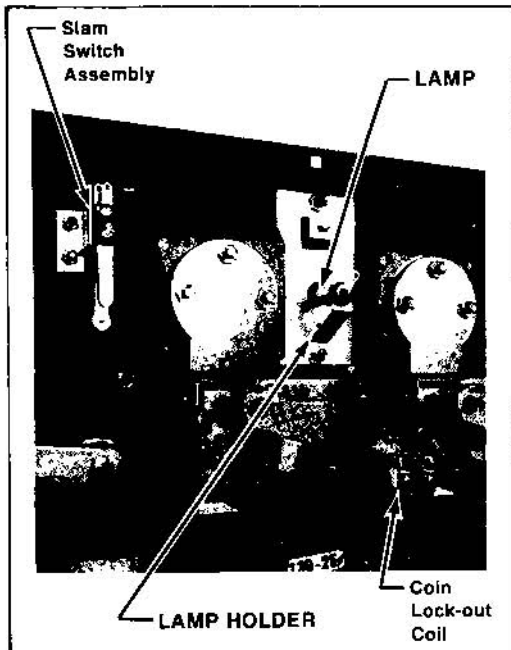

Figure 6 Coin Door Assembly

the lock-out coil is de-energized, causing the lock-out wires to move out far enough to divert coins over to the return chute.

Directly below each coin mechanism is a secondary coin chute and a coin switch with a trip wire extending out to the front edge of the chute. When the trip wire is positioned correctly, a coin passing down the secondary chute and into the coin box will momentarily push the trip wire down and cause the switch contacts to close.

Also shown in the photograph is a slam switch assembly. It has been included to defeat any players who might try to obtain free game plays by violently pounding on the coin door to momentarily close the contacts on a coin switch. The slam switch contacts connect to the microcomputer system, which will ignore coin switch signals whenever the slam switch contacts are closed.

### Access To Coin Mechanisms

To remove jammed coins, and for maintenance cleaning, each magnet gate assembly can be hinged open without removing it from the door, as shown in Figure 7. Or, if necessary, each coin mechanism can be entirely removed from the door merely by pulling



Figure 7 Hinging Open the Magnet Gate Assembly

back on a release lever and simultaneously tilting the mechanism back, then lifting it up and out. This is shown in Figure 8.



Figure 8 Removal of Coin Mechanism

#### Cleaning of Coin Paths

**CAUTION:**

*The use of an abrasive (such as steel wool or a wire brush) or a lubrication on a coin mechanism will result in a rapid build-up of residue.*

By talking to many operators, we have found that the best method of cleaning a coin mechanism is by using hot or boiling water and a mild detergent. A toothbrush may be used for those stubborn buildups of residue. After cleaning, flush thoroughly with hot or boiling water, then blow out all water with compressed air.

Figure 9 shows the surfaces to clean inside the coin mechanism. These include the inside surface of the mainplate, and the corresponding surface of the gate assembly. There may also be metal particles clinging to the magnet itself. To remove these you can guide the point of a screwdriver or similar tool along the edge of the magnet.

If coins are not traveling as far as the coin mechanisms, you will need to clean the channel beneath the coin slot. To gain access to this channel, use a  $\frac{3}{8}$ -inch wrench and remove all three nuts that secure the cover plate (refer to Figure 10). Removing the plate will provide access to the entire channel.



Figure 9 Surfaces to Clean Inside the Coin Mechanism



Figure 10 Removal of Plate Covering Rear of Coin Slot

Also clean the inside surfaces of the secondary coin chutes, but when doing this be careful not to damage or bend the trip wires on the coin switches.

#### LUBRICATION

Lubrication. Do not apply lubrication to the coin mechanisms. The only points that may need lubrication (and only rarely) are the shafts of the scavenger buttons (coin rejection buttons) where they pass through the coin door. Apply only one drop of light machine oil, and be positive that no oil drops down onto a coin mechanism. Figure 11 shows this lubrication point.

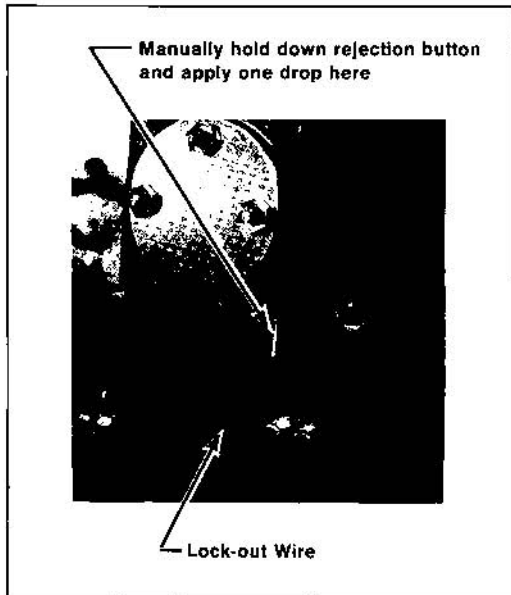

Figure 11 Close-up View of Lubrication Point

#### Adjustment of Coin Switch Trip Wire

In order for a coin switch to operate reliably when a coin travels down the secondary coin chute, the rest position of its trip wire should be as shown in Figure 12. Use extreme care when handling or touching these wires.

#### Mechanical Adjustments on Coin Mechanism

Coin mechanisms are adjusted prior to shipment from the factory and normally will retain these adjustments for many months. If, due to wear or other causes, it becomes necessary to make new adjustments, remove the coin mechanism from the coin door. Then take it to a clean, well lighted area where it can be placed in a vertical position on a level surface (such as a bench top). Besides a screwdriver, you will need a set of several coins, including both new and old, worn ones. Figure 13 shows an exploded view of the mechanism and gives procedures for adjusting the kicker, separator, and the magnet gate. These adjustments should only be done by someone who has experience in servicing coin mechanisms and who understands their operation.

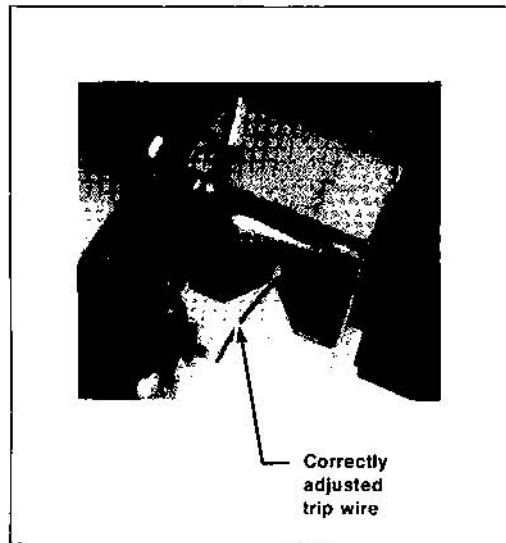

Figure 12 Detail View of Coin Switch and Trip Wire

#### General Troubleshooting Hints

The first action is to look for jammed coins. After these have been removed, examine the coin path for presence of foreign material or loose objects (such as chewing gum, small metallic objects, paper wads, etc.). In cases where game usage is heavy, it may be necessary to clean the entire coin path periodically, in order to prevent build-up of contaminants that can hinder the movement of coins through the mechanisms. Also confirm that the trip wire on each coin switch is intact, and is properly adjusted. If troubles still persist, check the conditions and positions of the lock-out wires, and the mechanical adjustments on the coin mechanisms, before suspecting the electronics. If a coin mechanism rejects genuine coins, try to readjust it. If this is not successful, then replace it with a working mechanism.

#### C. ADJUSTMENTS ON TV MONITOR

##### NOTE

*The TV monitor is accessible only from inside the game cabinet and these adjustments have to be done while the game is energized. Therefore only persons familiar with safety measures and repair procedures on electrical equipment should perform them.*

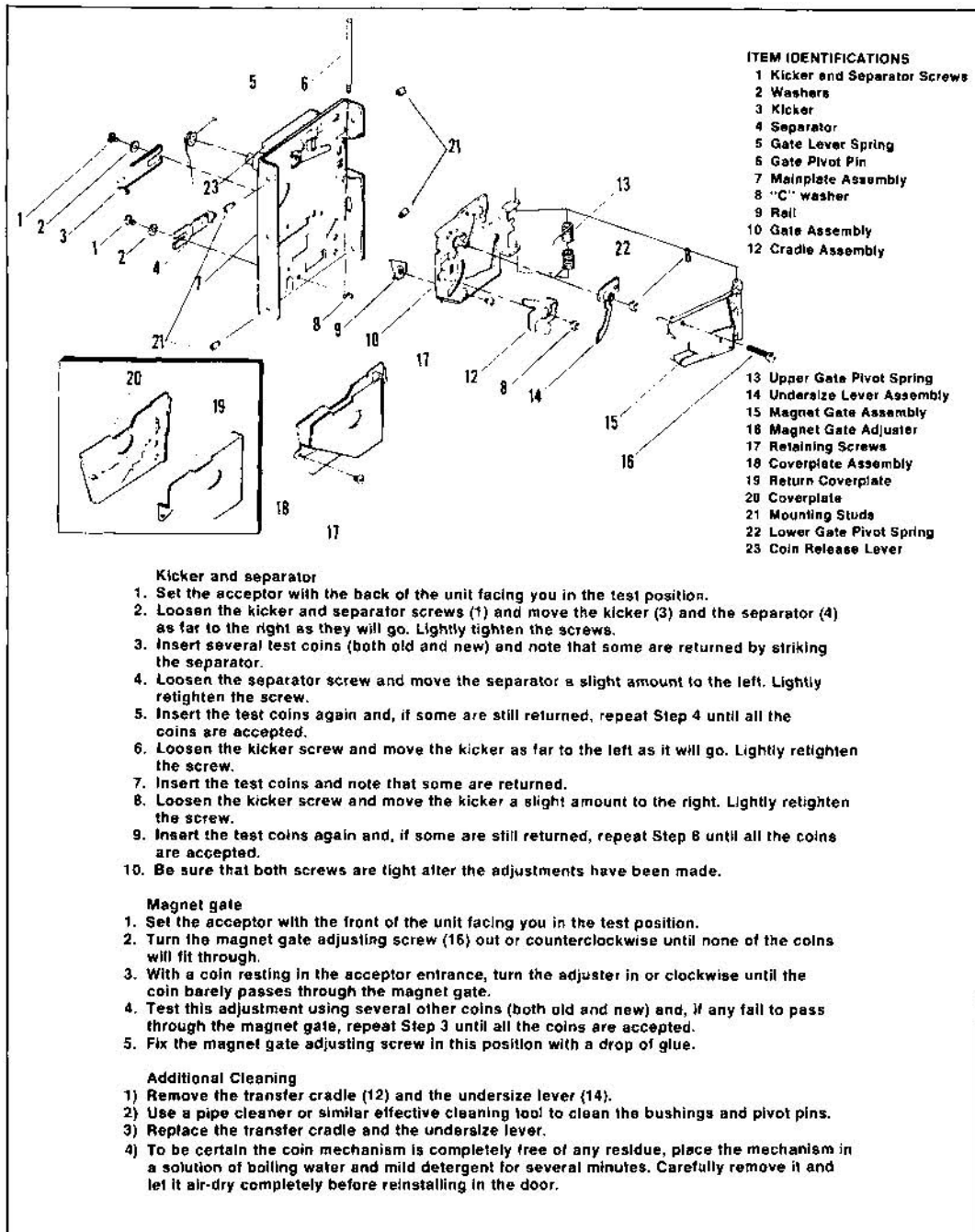

Figure 13 Adjustments on Coin Mechanism

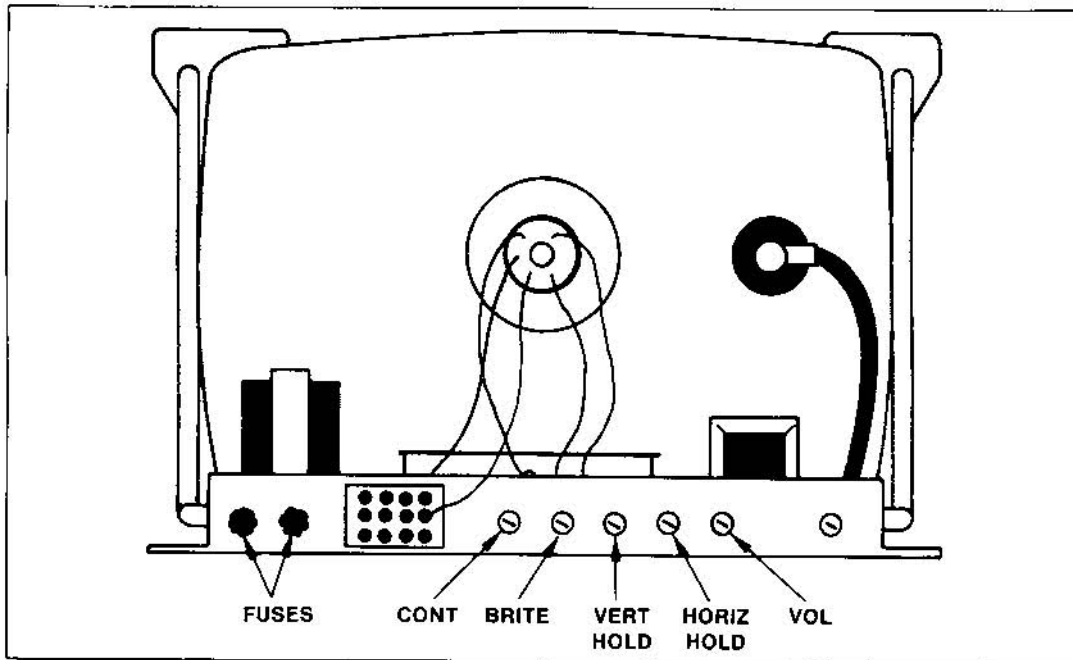

Figure 14 Locations of Adjustments on TV Chassis

The TV monitor need be adjusted *only* when the picture is distorted, or if the contrast or brightness seem out of adjustment.

The monitor's adjustments function like those of a conventional commercial television set, except that the volume adjustment has no effect. Instead the game produces its sound in circuits separate from the TV monitor. Figure 14 shows the location of the adjustments on the rear of the chassis. When making the adjustments, follow these general guidelines:

- BRITE (Brightness)**—Perform this adjustment before the contrast. Adjust so that the white lines covering the screen just barely disappear, when the brightness is turned up.
- CONT (Contrast)**—Adjust so that the images are as bright as possible against the dark background without being blurred.
- HORIZ HOLD (Horizontal Hold)**—Adjust if the picture is slightly off-center horizontally, if the images appear warped, or if the picture is broken up into a series of diagonal lines. Adjust for a stable, centered picture.

**VERT HOLD (Vertical Hold)**: -This needs adjustment only if the picture appears to be rolling up or down the screen. Adjust for a stable, centered picture.

**D. TV MONITOR REMOVAL**

If the TV monitor proves to be at fault, remove the monitor as shown in Figure 15.

**E. FUSE REPLACEMENT**

Poolshark contains four fuses, two on the power supply assembly and two on the TV monitor assembly. These fuses are all easily accessible through the rear access door. Replace fuses only with the same type of fuse as follows:

- TV Monitor Fuses**  
3AG 1-amp slow-blow, 250 volts
- Power Supply Fuses**  
3AG 2-amp slow-blow, 250 volts

**F. LAMP REPLACEMENT**

Poolshark contains only two lamps, a type #47 incandescent lamp in the coin door and an eighteen-

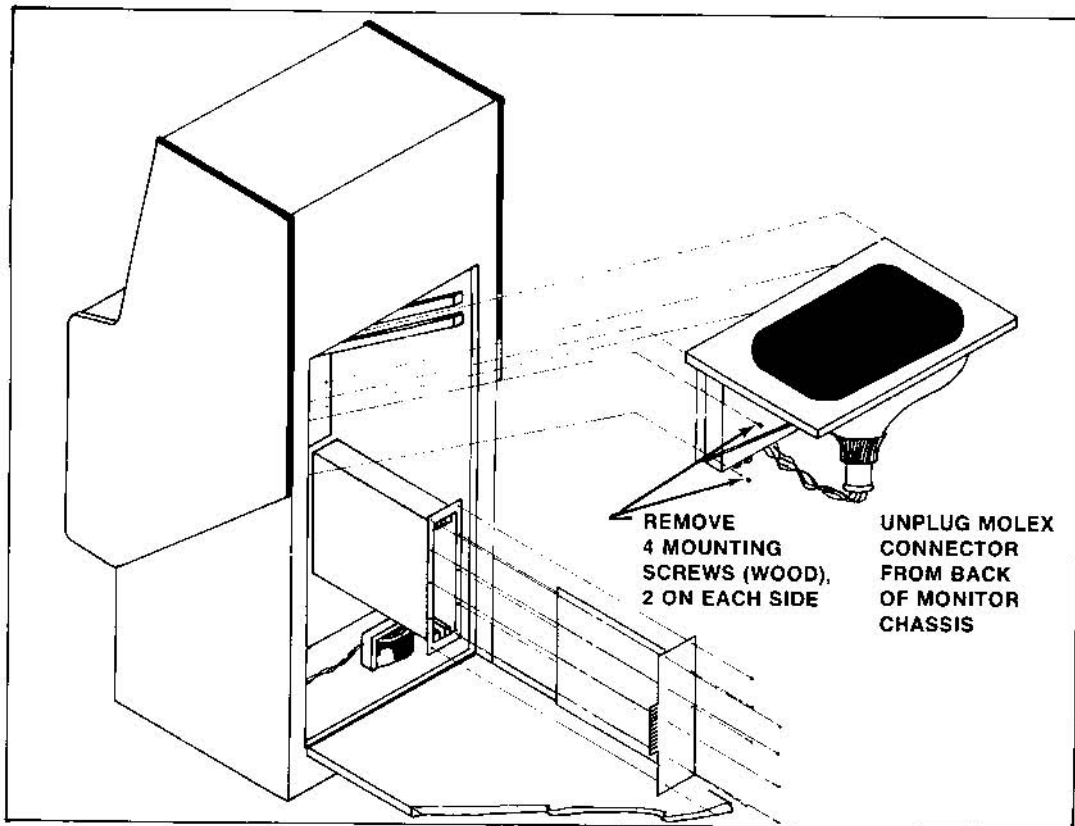

Figure 15 Removal of TV Monitor

inch fluorescent lamp inside the top of the game cabinet assembly. Refer to Figure 16 for instructions to replace the fluorescent lamp. To replace the coin door light bulb, remove the lamp holder mounting nut, replace the lamp, then remount the lamp holder (see Figure 6).

### G. START SWITCHES

There are two sets of identical game controls. These controls are both mounted on the front of the game cabinet directly in front of the TV monitor. The controls consist of two pushbutton switches and two joysticks.

The START pushbutton switches are backlit by light-emitting diodes (LEDs). These switches generally have a low failure rate. Therefore, before changing one, make sure that the switch or LED is bad.

To change a START pushbutton, unlock and open the coin mechanism door. Remove the wires from the defective switch. From the inside of the game cabinet, turn the switch counterclockwise while holding switch's cone-shaped nut on outside of cabinet. Install new switch using the reverse procedure. Connect harness wires as shown in Figure 17.

### H. JOYSTICKS

The joysticks in Poolshark contain two potentiometers. The potentiometers are made with a carbon resistive material.

Have you ever turned the volume up on a well-used radio and heard a static noise? That noise was the result of a worn carbon resistive volume control. What happens is that after turning the volume control up and down many times, it begins rubbing carbon

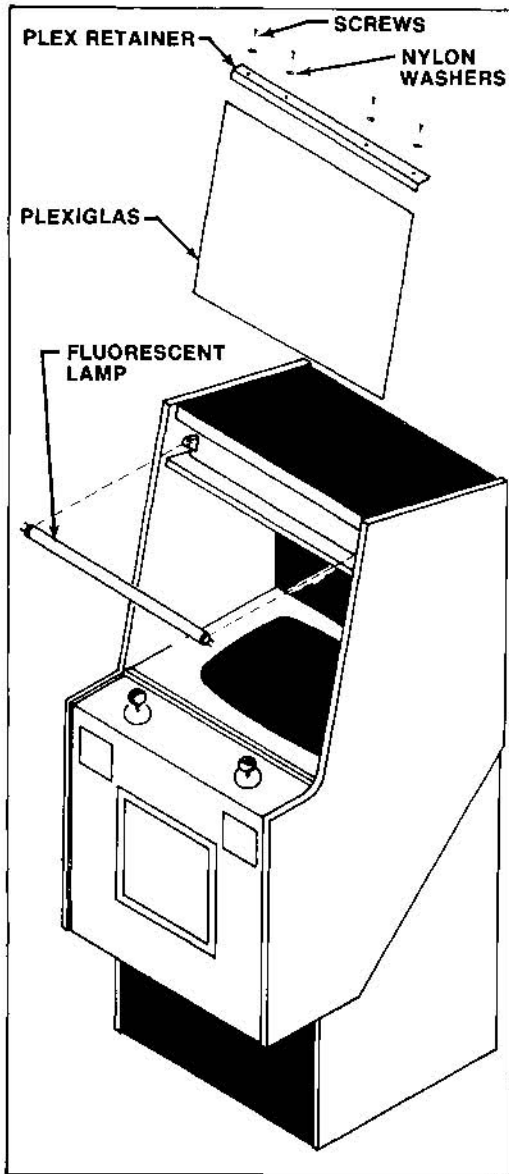

Figure 16 Removal of Fluorescent Lamp

material off of the potentiometer. This results in a fine carbon dust that causes the noise.

As in your radio, the Poolshark potentiometers can also begin to be noisy with use. The symptom of this noise in Poolshark is that the cue ball will jump (rather than an even movement) when the joystick is moved.

There are two ways to solve the problem of a noisy potentiometer: 1) Replace the joystick or 2) clean the potentiometer. Economically, cleaning is a better way of solving the problem. However, if some clown pours coffee or pop onto the control panel and the liquid seeps into the potentiometer, it is questionable whether cleaning will solve the problem. But it is worth a try. If cleaning the potentiometers doesn't solve the problem, then change the joystick as shown in Figure 18.

Cleaning the potentiometer is simple. All you will need is a spray can of tuner cleaner. Tuner cleaner is available at most radio and TV supply houses. When you buy a can of tuner cleaner, make sure you buy the little tube that plugs into the spray nozzle.

Clean each of the four joystick potentiometers as follows:

1. Unlock and open coin mechanism door.
2. Plug little spray tube of tuner cleaner into tuner cleaner spray nozzle.
3. Insert the other end of the little spray tube of tuner cleaner up into the potentiometer as shown in Figure 19.
4. Spray the potentiometer *once* for no longer than it takes to say the word "tick." Clean, don't drown the potentiometer.
5. Move the joystick lever in a rapid circular motion for about five seconds.
6. Repeat steps 3, 4, and 5 once for the same potentiometer.
7. Repeat steps 3 through 6 for each of the other three potentiometers.
8. Play a game of Poolshark and determine if problem is solved.



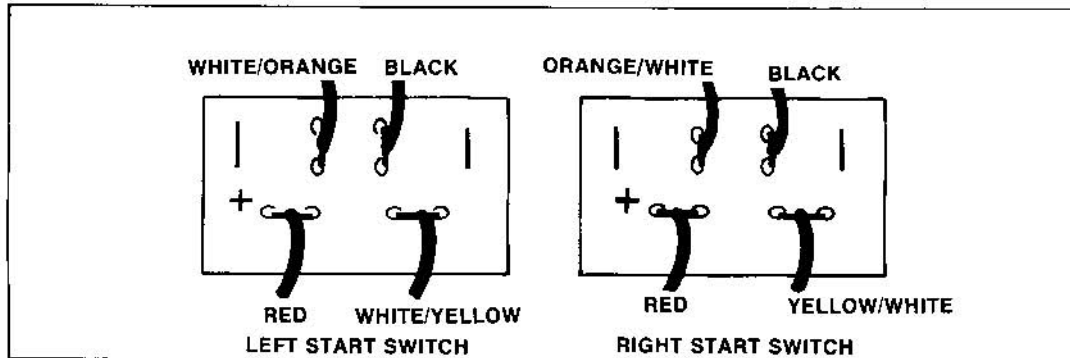

Figure 17 Harness Wire Connections on Start Switches

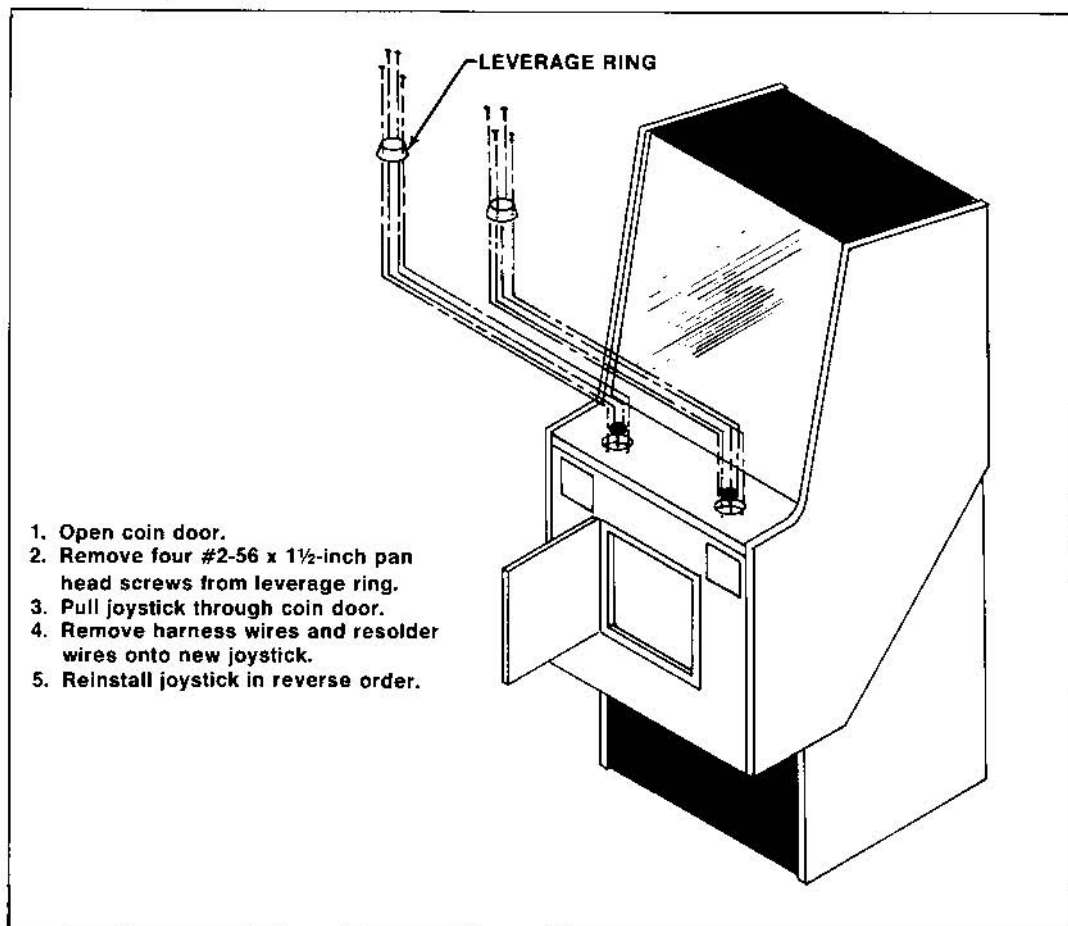

Figure 18 Removal of Joysticks

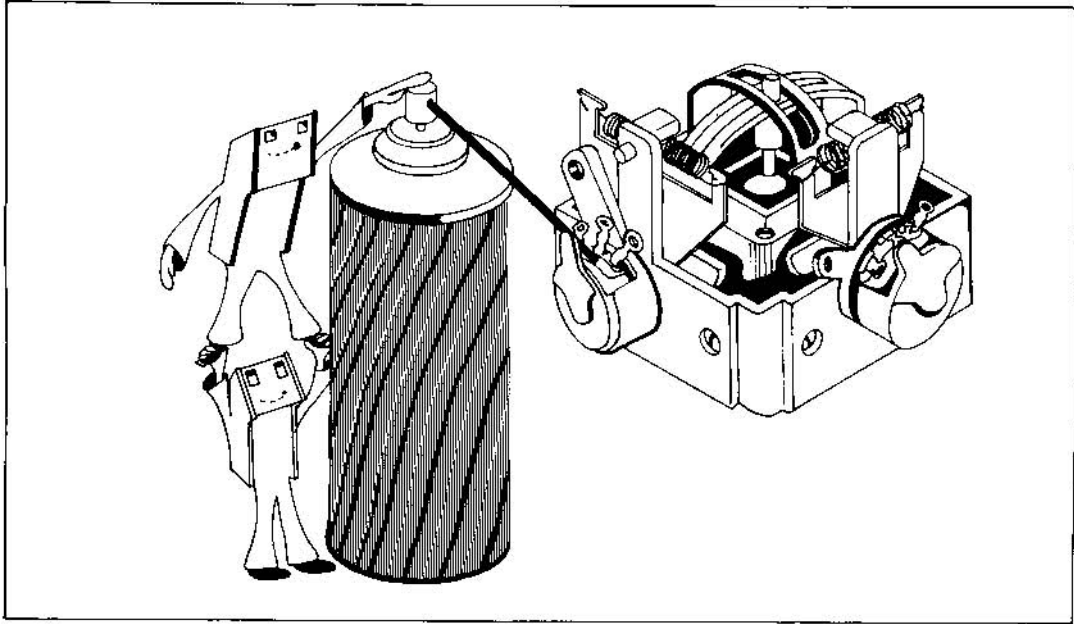

Figure 19 Cleaning Potentiometers with Tuner Cleaner



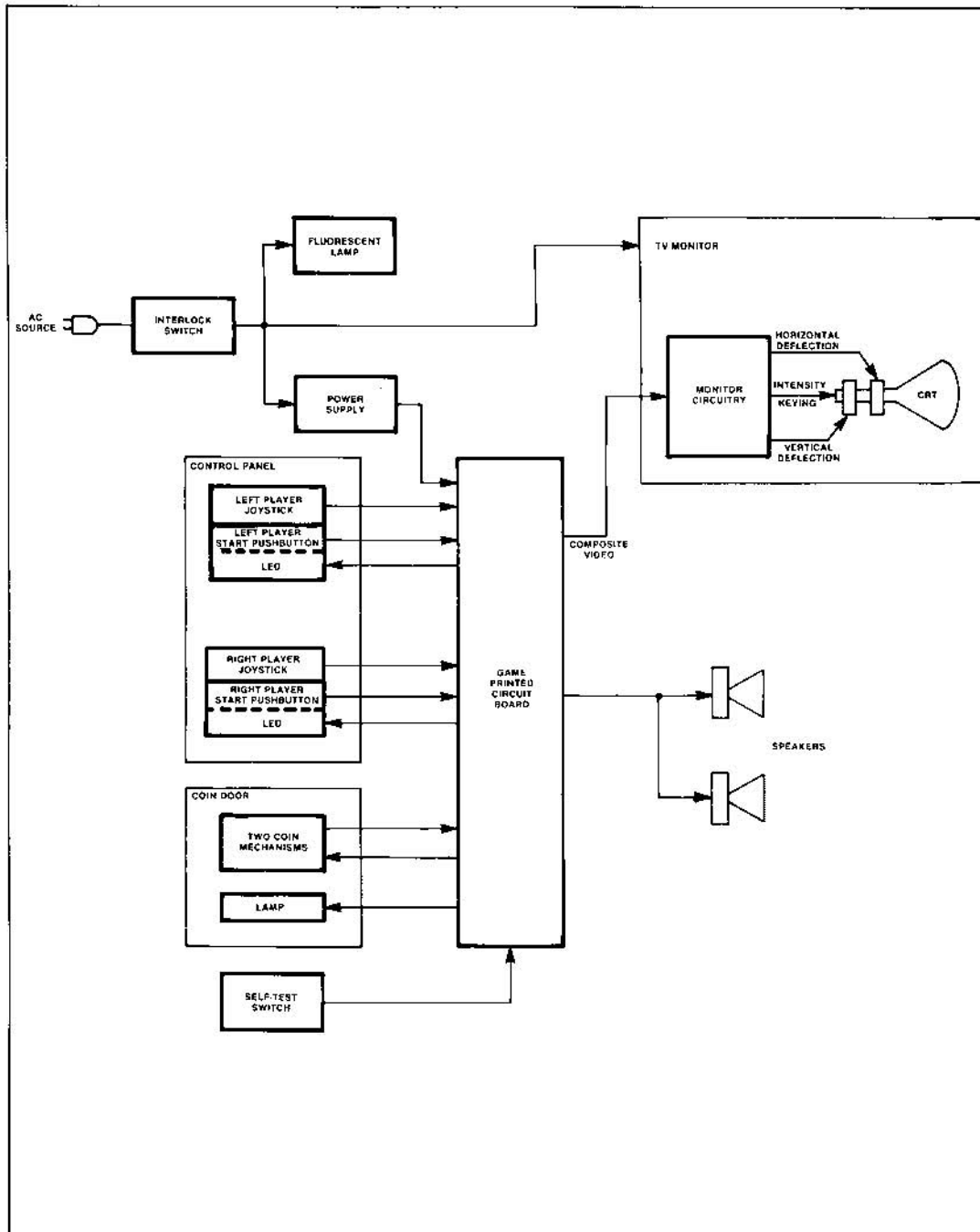

Figure 20 Poolshark Game Block Diagram

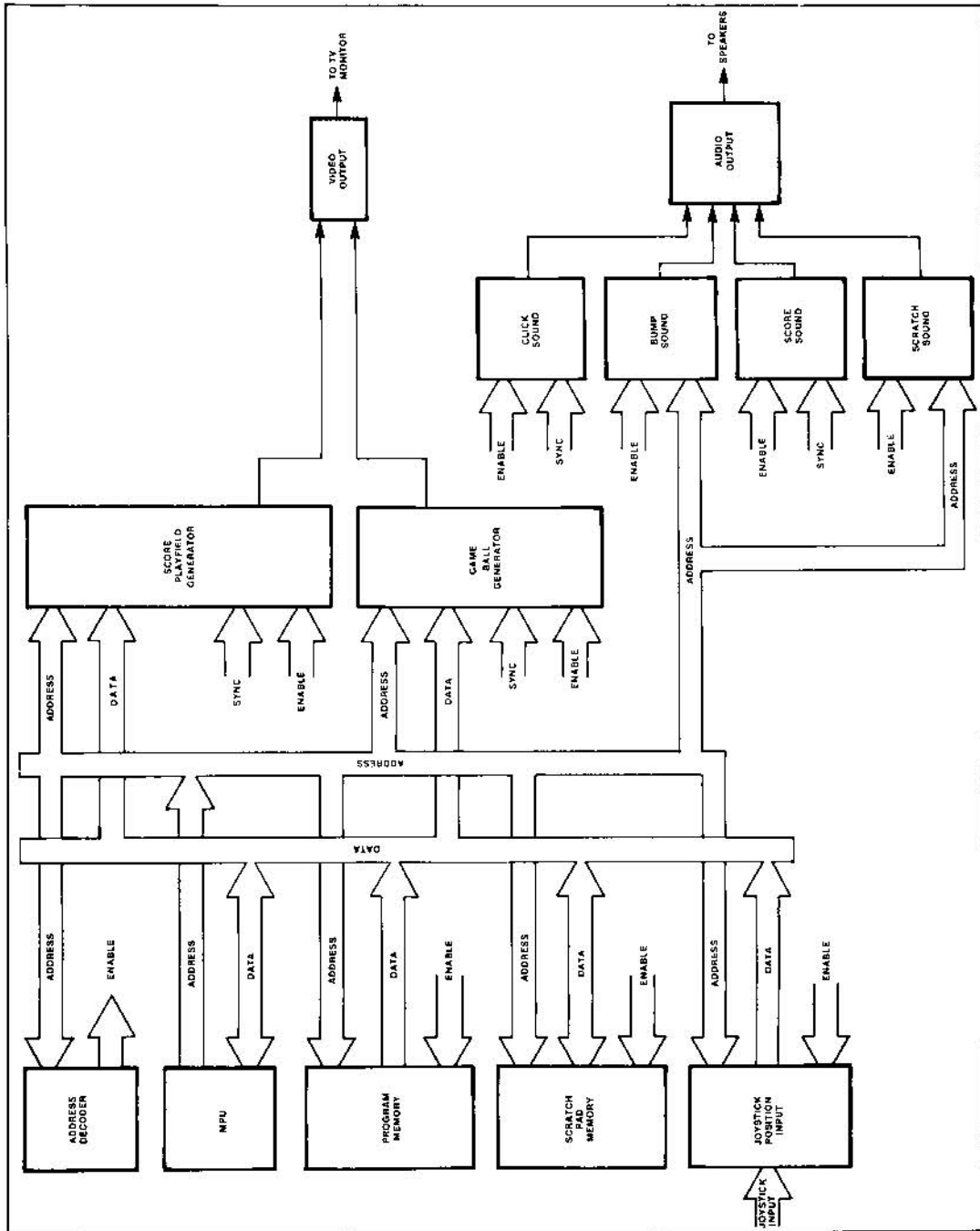

Figure 21 Poolshark PCB Block Diagram

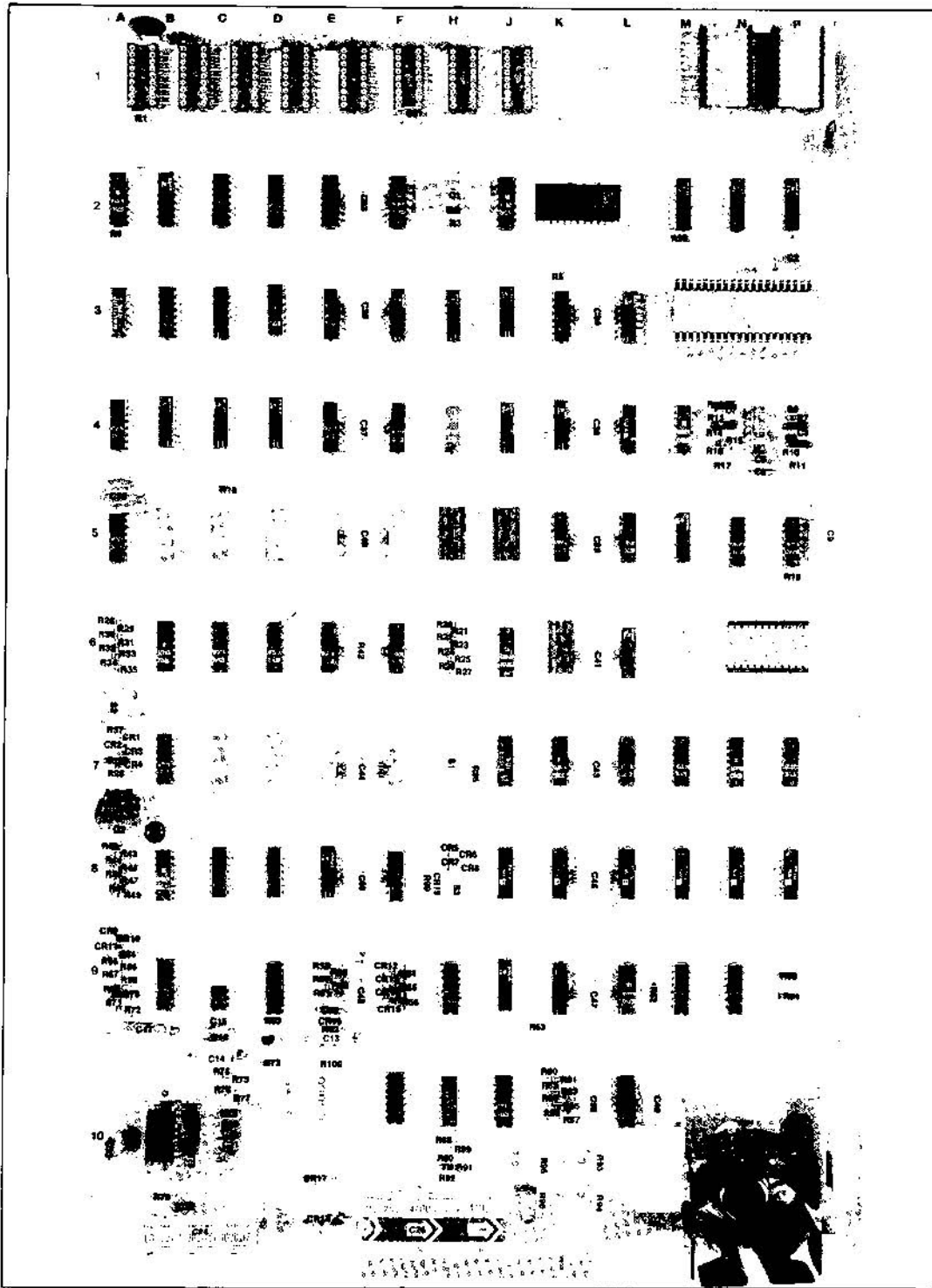

Figure 22 Poolshark Printed Circuit Board

Table 3 Aid for Locating Discrete Components  
in Figure 22

COMPONENT SCHEMATIC REFERENCE DESIGNATION	POOLSHARK PCB GRID LOCATION	COMPONENT SCHEMATIC REFERENCE DESIGNATION	POOLSHARK PCB GRID LOCATION
C1	H2	C49	L/M10
C2	P2/3	C50	K/L10
C3	P4		
C4	P4	CR1	A7
C5	N4	CR2	A7
C6	N4	CR3	A7
C7	M.N4	CR4	A7
C8	M.N4	CR5	H8
C9	P5	CR6	H8
C10	A7	CR7	H8
		CR8	H8
C11	A7	CR9	A9
C12	F9	CR10	A9
C13	E9:10		
C14	C9:10	CR11	A9
C15	C9	CR12	F9
C16	C9	CR13	F9
C17	A:B9	CR14	F9
C18	C10	CR15	F9
C19	C10	CR16	E9
C20	C10	CR17	D:E10
		CR18	D:E10
		CR19	F:H8
C21	C10		
C22	B:C10		
C23	A10	LM 323	N10
C24	B:C10		
C25	F:H10	Q1	B7:8
C30	P1	Q2	A7:8
C31	F1	Q3	D9
C32	A:B1		
C33	F:F2	R1	A:B1
C34	K:L3	R2	H2
		R3	H2
C35	E:F3	R4	A2
C36	K:L4	R5	K3
C37	E/F4	R6	P4
C38	A4:5	R7	P4
C39	K/L5	R8	P4
C40	E/F5	R9	P4
C41	K/L6	R10	P4
C42	E/F6		
C43	K/L7	R11	P4
C44	L:F7	R12	N4
C45	K/L8	R13	N4
C46	E/F8	R14	N4
C47	K/L9	R15	N4
C48	E/F9	R16	N4

Table 3 (continued)  
Aid for Locating Discrete Components in Figure 22

COMPONENT SCHEMATIC REFERENCE DESIGNATION	POOLSHARK PCB GRID LOCATION	COMPONENT SCHEMATIC REFERENCE DESIGNATION	POOLSHARK PCB GRID LOCATION
R17	N4	R61	E9
R18	C4/5	R62	E9
R19	P5	R63	D9
R20	H6	R64	A9
		R65	A9
R21	H6	R66	A9
R22	H6	R67	A9
R23	H6	R68	A9
R24	H6	R69	A9
R25	H6	R70	A9
R26	H6		
R27	H6	R71	A9
R28	A6	R72	A9
R29	A6	R73	D9/10
R30	A6	R74	C9/10
		R75	C9/10
R31	A6	R76	C10
R32	A6	R77	C10
R33	A6	R78	C10
R34	A6	R79	B10
R35	A6	R80	K9/10
R36	A7		
R37	A7	R81	K9/10
R38	A7	R82	K10
R39	A7	R83	K10
R40	A7	R84	K10
		R85	K10
R41	A7	R86	K10
R42	A8	R87	K10
R43	A8	R88	H10
R44	A8	R89	H10
R45	A8	R90	H10
R46	A8		
R47	A8	R91	H10
R48	A8	R92	H10
R49	A8	R93	L10
R50	P9	R94	L10
		R95	J/K10
R51	P9	R96	J/K10
R52	L/M9	R97	P10
R53	J/K9	R98	M2
R54	F9	R99	F/H8
R55	F9	R100	E9/10
R56	F9		
R57	E9	S1	H7
R58	E9	S2	A6/7
R59	E9	S3	H8
R60	E9		
		Y1	H2



### Poolshark PCB Overview (see Figure 22)

For easy reference, the PCB is divided into 130 sections. These sections are identified by letters A through P (skipping letters G, I, and O because they may be easily confused with numbers 6, 7, and 0 respectively) for the short side of the PCB. The long side of the PCB is identified by numbers 1 through 10. The letters and numbers create a grid and all ICs are located on the PCB along the grid lines. For example, identify the IC at location E3. This IC is located on the PCB schematic diagram, Figure 23 (sheet 1, top left-hand corner) as IC E3.

Discrete components (resistors, capacitors, diodes, transistors, etc.) are not identified on the PCB schematic diagrams. Therefore, Table 3 is provided as an aid to be used with Figure 22 to locate discrettes on the PCB.

Note that in location M/N/P 10 there is an LM232 regulator (located in large black heat sink) and a 4Ω 10-watt power resistor. These components produce a good deal of heat during normal operation. The temperature is not extreme, but touching sensitive skin will produce an OUCH!

Another item we would like to bring to your attention is power distribution. Note that on top of the PCB, *most* of the wide traces are DC ground. On the back of the board the wide trace (along the long end of the board) is +5 VDC.

### C. POOLSHARK PCB POWER (see Figure 23, Sheet 1 of 4)

The PCB receives its power from the power supply in two forms: approximately 8 volts full-wave-rectified DC and 25 volts AC. The 8 VDC is regulated by an LM323 to a stable +5 VDC. The 5 VDC is then distributed throughout the board to power all circuits, excluding the audio output IC. The audio output IC (TDA 1004 in location B10) receives its power through full-wave rectifier CR17 + CR18 and filter C25.

The +5 VDC regulated voltage is also fed through 1kΩ resistors R1, R4, R18, R19, R36, and R65. This voltage is a pull-up voltage labeled P on the schematics. A pull-up voltage is used in output circuitry that is too heavily loaded to get to the high logic state by itself.

### D. POOLSHARK MICROCOMPUTER (see Figure 23, Sheet 3 of 4)

The microcomputer consists of the microprocessor or program memory, and scratch pad memory. The microprocessing unit or MPU (location M/N/P 3) is the controller of the microcomputer. From the MPU, a sixteen-bit address bus addresses program memory, scratch pad memory. An eight-bit bi-directional data bus serves as a path for transferring data to the MPU from program memory, from the switch circuits, and to and from scratch pad memory.

The address lines (BA0 through BA14) are buffered to eliminate signal loading. The lower-numbered lines (BA0 through BA8) address the program memory ROMs (K1 and L1 or A1, B1, C1, D1, E1, F1, H1 and J1). Scratch-pad memory RAMs (N1 and P1) are also addressed by these same eight address bits.

The higher-numbered address bits (BA10 through BA13) address the address decoder. The address decoder's outputs enable the section of program memory or the scratch-pad memories—as commanded by address bits BA10, BA11, BA12 and BA14. The LEGIT signal from the MPU and address bits BA13 and BA14 enable the address decoder.

The LEGIT signal from the MPU is derived from phase 2 (Ø2) and VMA. Phase 1 and phase 2 (as illustrated in Figure 24) are constant signals, derived from CLOCK. The VMA signal is an output of the MPU and only exists when the MPU expects a data transfer. Therefore, when the MPU wants a data transfer, it sets up the address lines and sends out a VMA signal; then, when phase 2 goes high, the address decoder is enabled by LEGIT. The output of the address decoder enables the appropriate memory and the transfer is made.

The outputs of the address decoder also enable the score/playfield RAMs, the sound circuits, the object and match RAMs, the START LEDs, and the D-A Latch.

### E. MICROCOMPUTER INTERFACE

The Poolshark game's microcomputer interfaces with the following circuits: motion circuit, switch distribution circuit, score/playfield circuit, sound circuits, lamp circuits, and joystick circuits.

#### Motion Circuit (see Figure 23, sheets 1 and 2)

During the vertical blanking period, the microcomputer directly accesses the vertical and horizon-

tal position RAMs (C7, D7, E7, F7). Data (BD0 through BD7) is written into the position RAMs at address locations BA0 through BA3 (signals PA1 through PA4 – PSA1 through PSA4 = BA0 through BA3). This is the only period during which the microcomputer has access to the motion circuit.

During the horizontal blanking period, the vertical position of each scan line is determined by full adders (E6, F6). When the vertical position (VP4 through VP8) of an object is equal to the vertical sync count, the output of full adder F6 becomes all high logic. This results in a low read/write line of the object RAMs (C5, D5, E5, F5) and match RAM (B5). The data written into the RAMs is the object code data (PA1 through PA4) for each horizontal position address location (HP1 through HP8).

In review, the microcomputer instructs the motion circuitry where the objects are to be displayed during vertical blanking. During horizontal blanking, the stored object horizontal location information is accessed and the object code is written into the object and match RAMs before the next horizontal scan line. This defines where that object is to appear on this scan line.

Now remember, horizontal position data was written into the object RAMs and match RAM during the horizontal blanking period, before the scan line began. During horizontal scan time, the object and match RAMs are addressed by horizontal sync 2H through 256H. When the horizontal sync count reaches an address location where match data was stored, a MATCH pulse appears at the output of the match RAM (B5). The pulse is clocked through flip-flop A5 and latches an object code (OBJ1 through OBJ4) at the output of flip-flop B6. The MATCH pulse is fed back to the read/write line of the match RAM to clear the current MATCH pulse.

Ball ROM J5 (sheet 2 of Figure 23) is enabled for balls zero (the cue ball) through ball seven, and ROM H5 for ball eight through ball fifteen. Object code bits OBJ1 through OBJ3 are address inputs A6, A7, and A8 of the ball ROMs. The vertical data code (VD1 through VD4) comes from full adder E6 (sheet 1 of Figure 23). The full adder outputs a vertical data code from zero to fifteen that instructs the ball ROMs which of the sixteen ball picture lines is being scanned. This code is address inputs A2 through A5 of the ball ROM.

The least significant address bits of the ball ROMs are horizontal data bits HD3 and HD4. These

along with HD1 and HD2 are generated by counter J3 at a sync rate of 1H and initiated by the MATCH pulse. The counter counts up to sixteen and inhibits itself by the terminal count signal OBJ DISP. Horizontal data bits HD1 and HD2 are gated into the PE input of shift register K4 (pin 9). The gating of these two bits shifts the ball ROM data out of the register once for every four counts of 1H. Since horizontal data code HD3 and HD4 changes every four counts of 1H, the results is a ball picture that is sixteen bits wide.

If the ball object code is 0000, the cue ball is displayed. In this situation an additional circuit is utilized. This circuit is that relating to flop-flop B3 (located above the ball ROMs on sheet 2). A cue ball object code produces a high Q BALL output at AND gate C3 for each high OBJ BALLS bit that is shifted out of register K4. This produces a white cue ball video when OBJ BALL signal is gated with the Q BALL signal at the video summer (sheet 1). Balls one through fifteen are scanned in black video.

#### Switch Distribution Circuit (see Figure 23, sheet 3 and 4)

During the attract and ready-to-play modes, the microcomputer enables the switch distribution circuit with a SWITCHES (J7, pin 1) signal and addresses (BA0 and BA1) the circuit for a resulting DIST 1, 2, or 3 signal. Then the microcomputer looks for a returning SW1, 2, 7, or 8 signal. If the logic is high, the switch is open, if low, the switch is closed.

During the play mode, the microcomputer enables this circuit to determine the position of the joysticks.

#### Score/Playfield Circuit (see Figure 23, sheet 2 of 4)

During the vertical blanking period, this circuit is addressed (BA0 through BA9) by the microcomputer. The address is passed through multiplexers L7, M7, and P7 to the address inputs of RAMs J8, K8, M8, N8, and P8. At this time data (BD0 through BD5) for each address location is written into the RAMs.

During scan time, the RAMs are addressed by vertical sync (A5 through A9) and horizontal sync (A9 through A4). When the vertical sync reaches an address location in which data was written, the horizontal data for that scan line is clocked through flip-flops K7 and N7. The horizontal data addresses the score/playfield ROM. The output of the ROM is multiplexed, one bit at a time, then clocked through flip-flop D3 at a rate of 1H.

#### **Sound Circuits (see Figure 23, sheet 4 of 4)**

There are four sound circuits: scratch, click, score, and bump. All four of these signals are summed at the input of audio amplifier B10. The scratch sound is generated by the microcomputer and clocked through flip-flop N9 (output pin 5). Bump is generated by the microcomputer and gated with vertical sync signal 128V.

Score sound begins with  $\overline{\text{SCORE}}$  enabling signal that permits counter E8 to count at a rate of 64V. The outputs of E8 are applied to a resistive network that results in the threshold of the timer C9 operating at an analog rate. At the count of sixteen, the terminal count (TC) of counter E8 is gated back to end the 64V count input. Also TC disables timer C9.

Click sound is enabled by  $\overline{\text{CLICK}}$ . The sound is derived from sixteen pulses of sync signal 2V. On the sixteenth pulse, counter J9 is inhibited by terminal count (TC).

#### **Lamp Circuits (see Figure 23, Sheet 4 of 4)**

The START lights are enabled with a  $\overline{\text{START LIGHT}}$

signal, then addressed by address bits BA1 and BA2 and clocked through flip-flops M9 by address bit BA0.

Note that the schematic illustrates two different types of START lights. Most production models of Poolshark will have the LEDs. However later models may have the incandescent lamps as shown in the dashed box on the schematic.

#### **Joystick Circuits (see Figure 23, Sheet 4 of 4)**

The voltages from the joysticks' potentiometers are applied to differential amplifiers J10. The differential outputs of J10 are applied to the positive inputs of comparators H10. The microcomputer then strobes the input of D-A latch B9 with data bits BD0 through BD3. The analog output of the D-A latch is applied to the negative input of comparator H10. When the analog conversion of data BD0 through BD9 equals the joystick position data, the output of Multiplexer F10 is a low logic signal. This tells the microcomputer where the joystick is, and the microcomputer moves the ball in the appropriate direction.

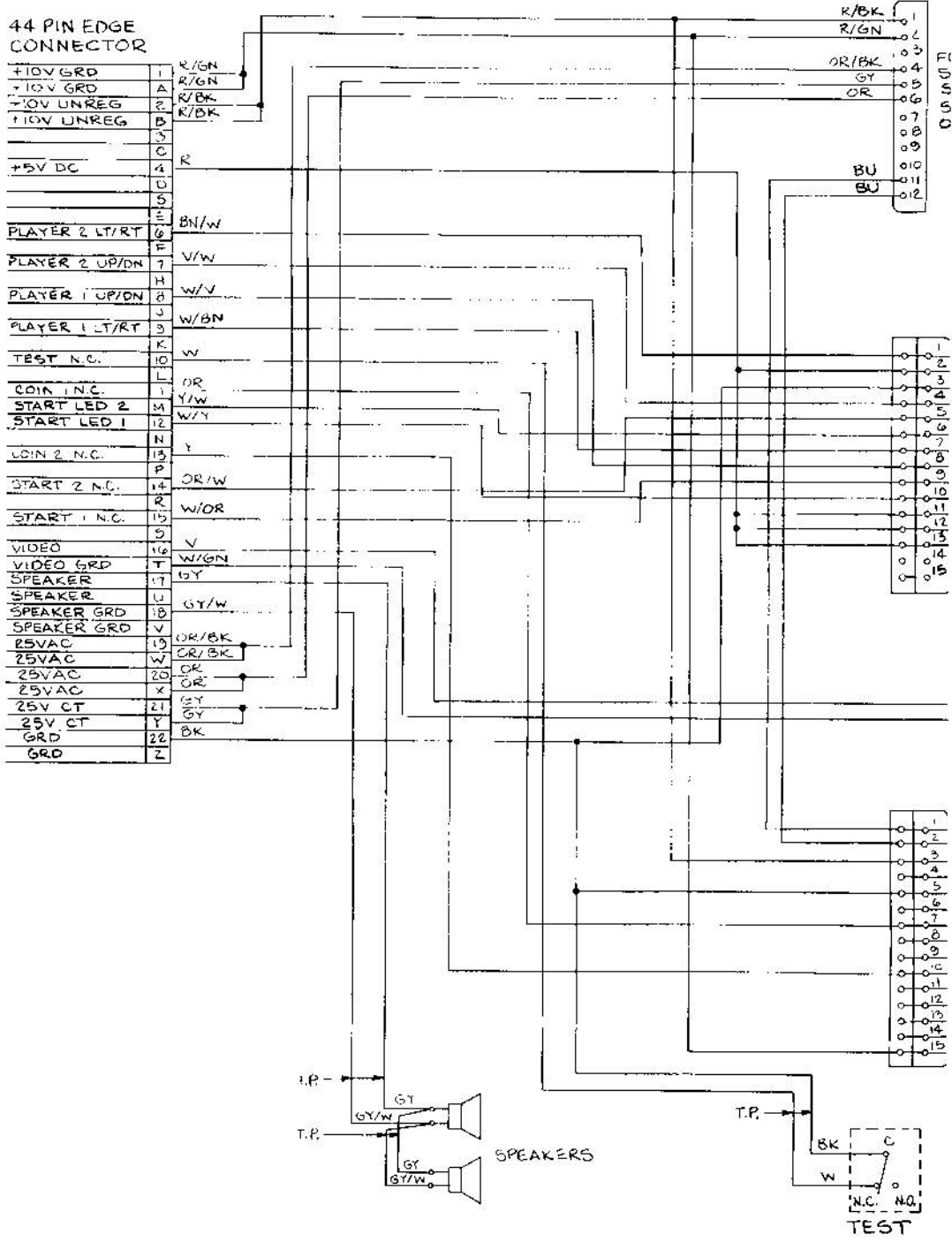

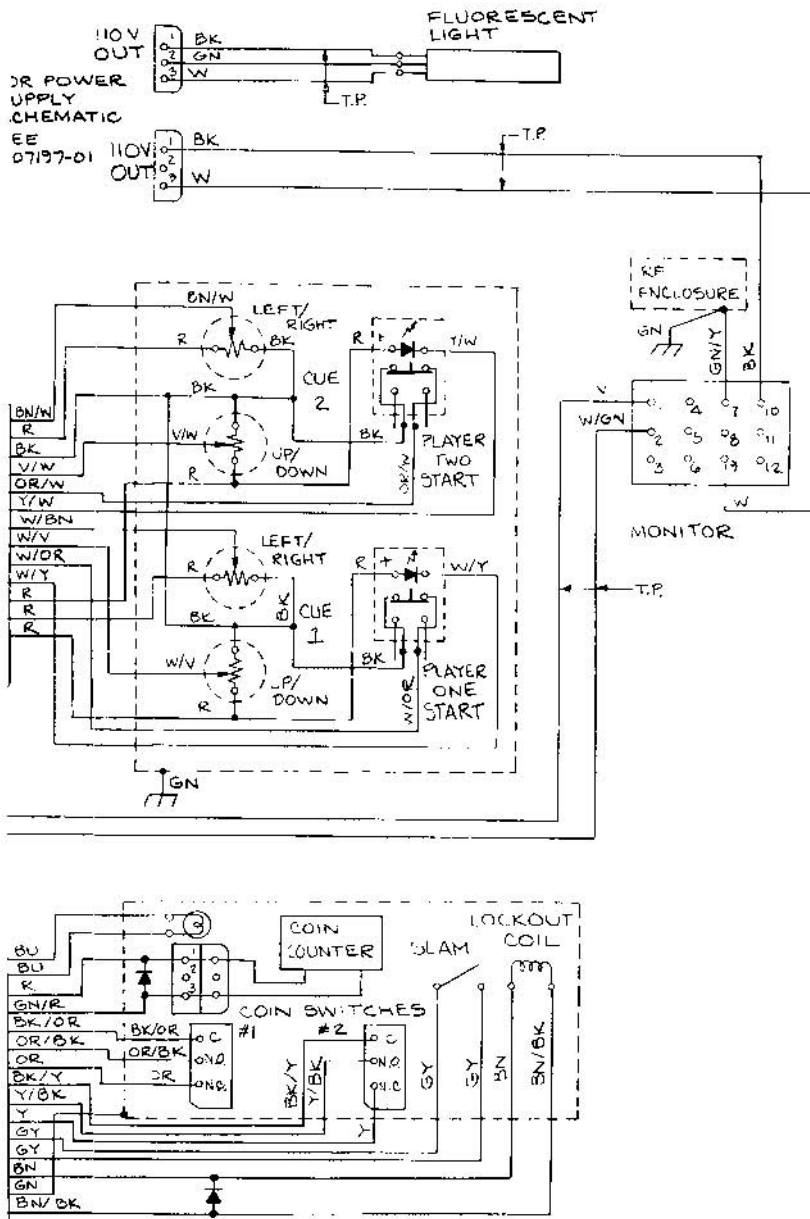

**HARNES SCHEMATIC**

Figure 23 Schematic Diagram (Sheet 1)

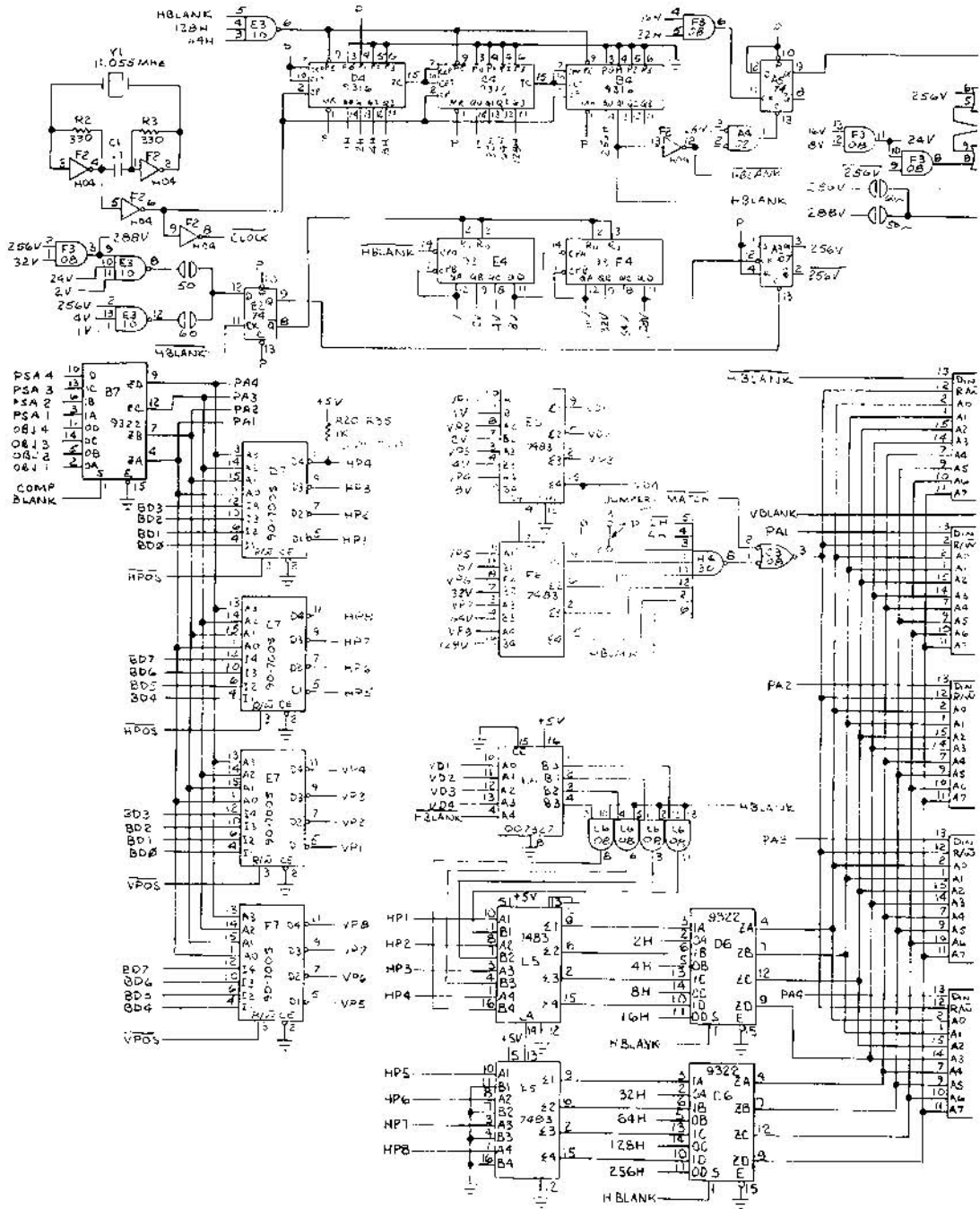



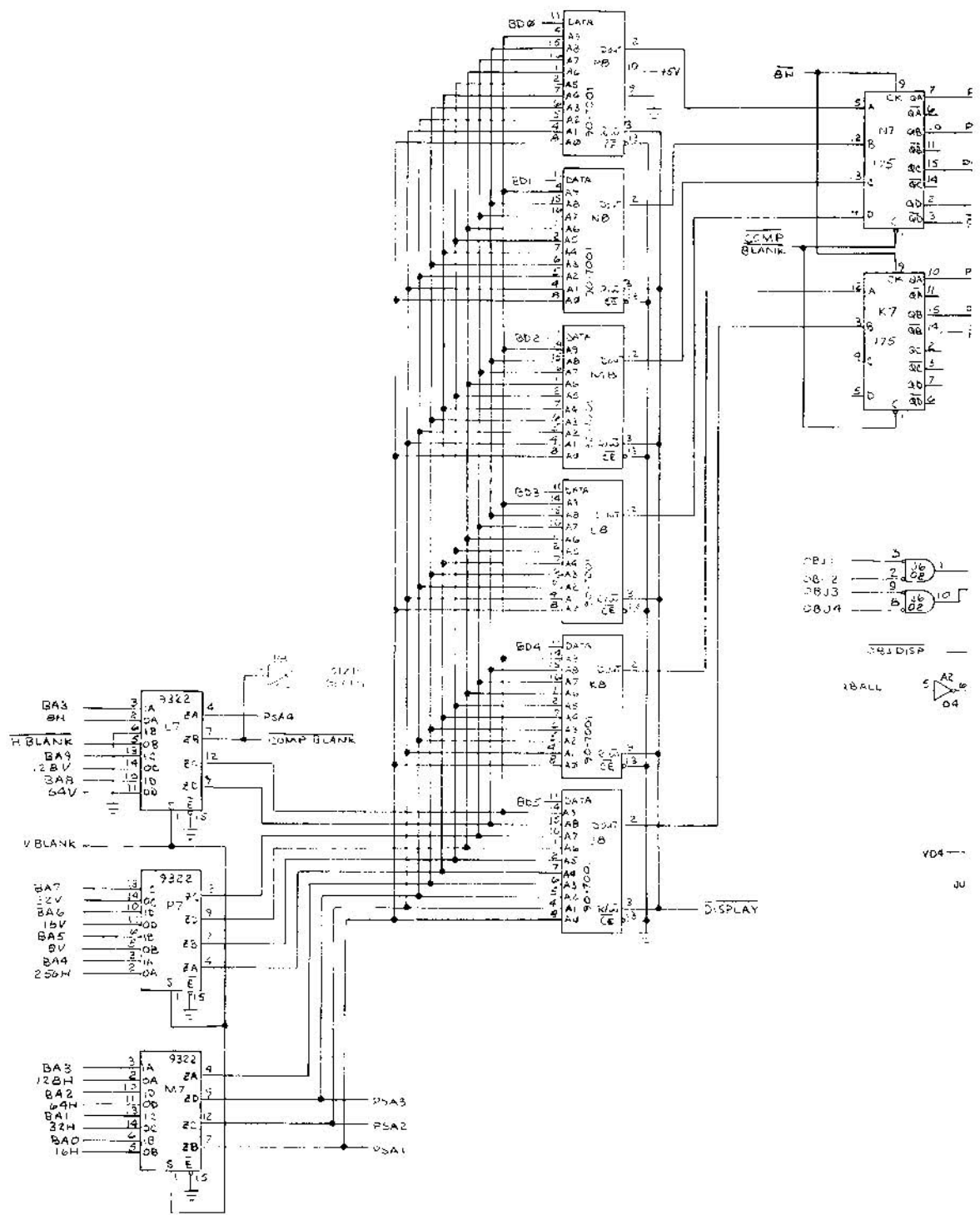







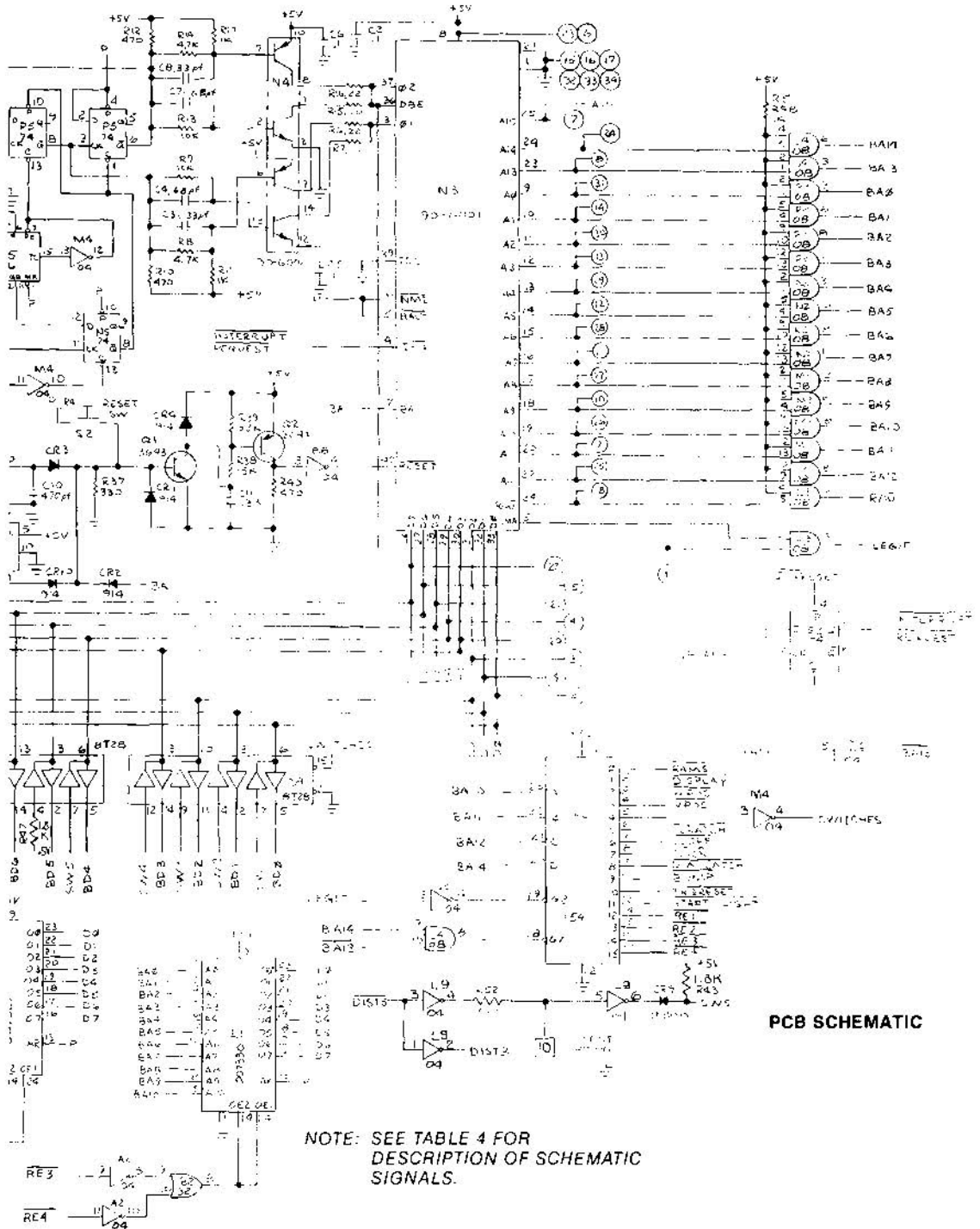

**PCB SCHEMATIC**

Figure 23 Schematic Diagram (Sheet 4)

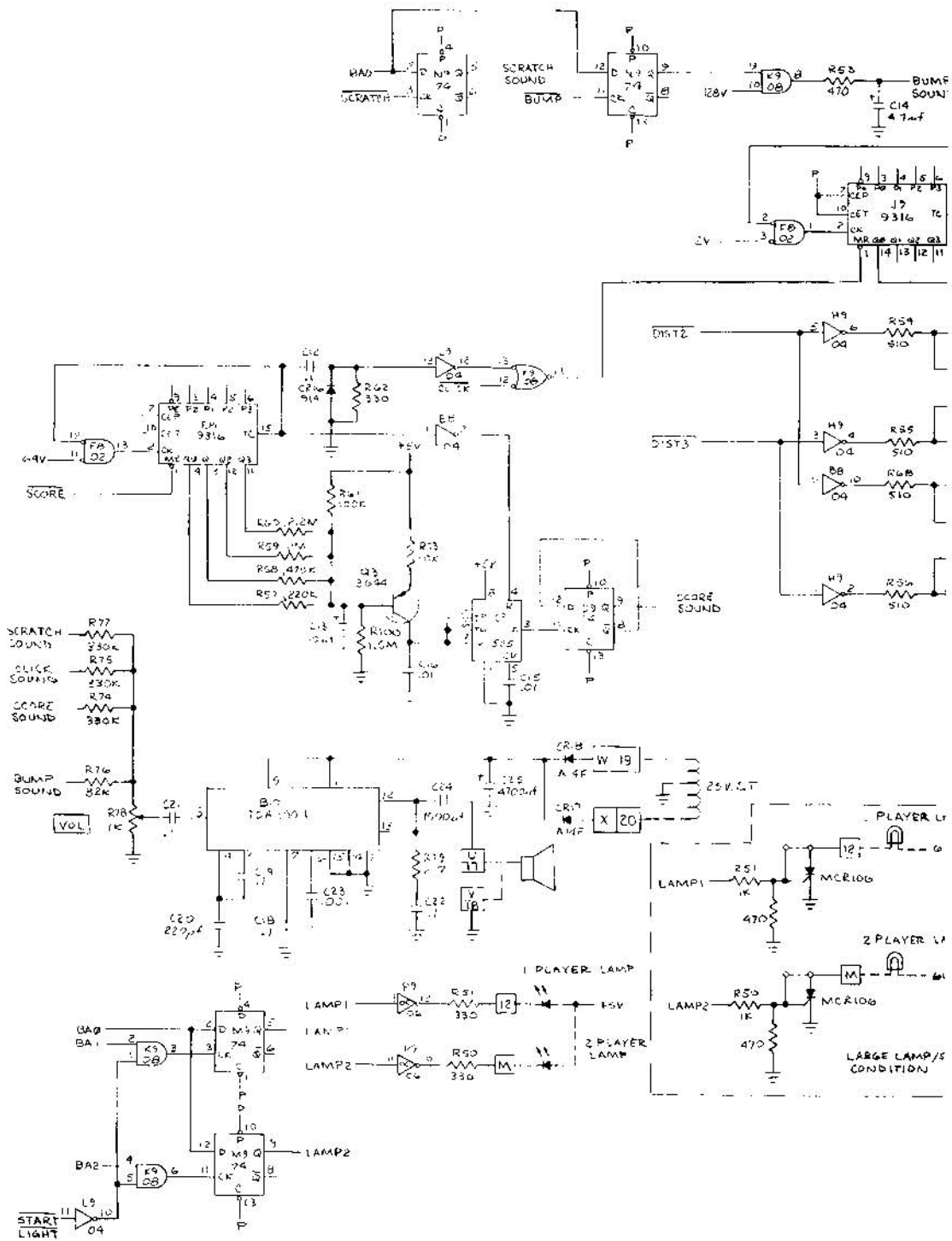



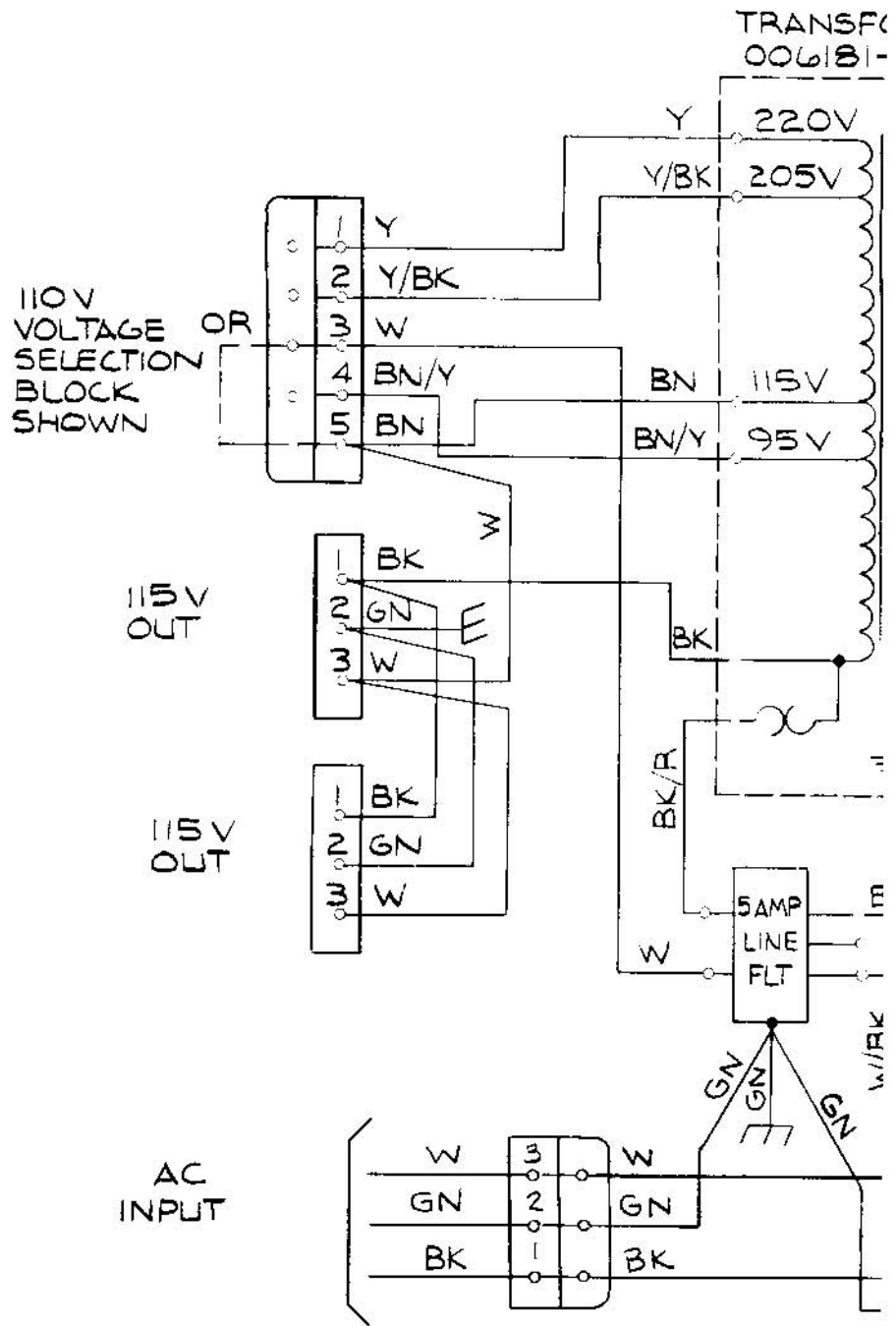

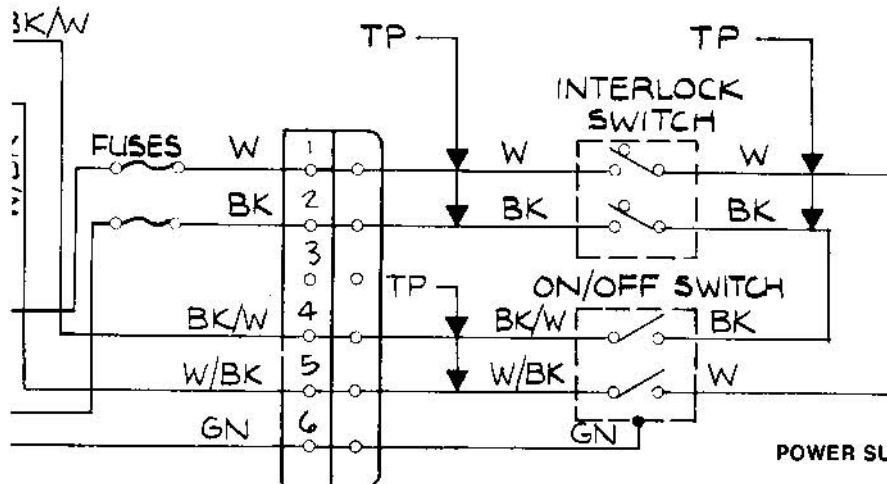
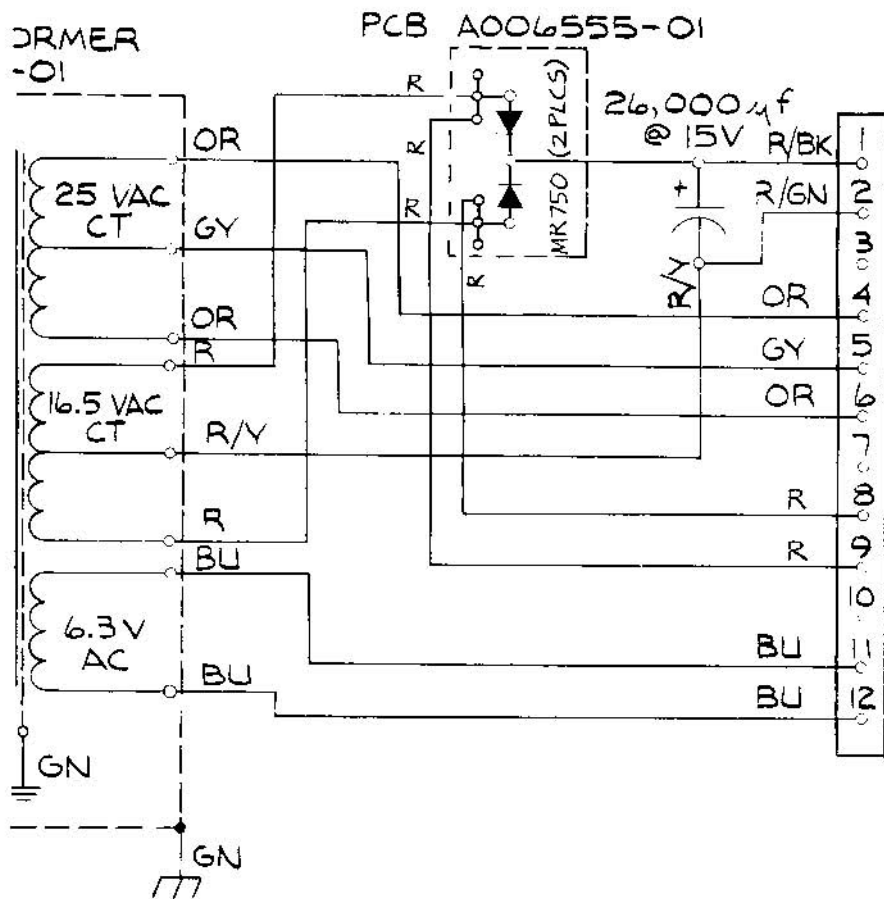

POWER SUPPLY SCHEMATIC

Figure 23 Schematic Diagram (Sheet 6)

**Table 4 Definitions of Schematic Signal Nomenclature**

Schematic Signal	Signal Description
A	Address—Address lines A0 through A15 generated by the microprocessor.
BA	Buffered Address—Address lines BA0 through BA14 generated by the microprocessor and buffered to eliminate signal loading.
BD	Buffered Data—Bi-directional buffered data lines BD0 through BD7 to and from the microprocessor.
$\overline{\text{BUMP}}$	Bump Not—Enabling signal from address decoder that enables the bump sound when signal is low.
BUMP SOUND	Bump Sound—Sound signal derived from address signal BA0 and 128V, enabled by $\overline{\text{BUMP}}$ .
$\overline{\text{CLICK}}$	Click Not—Enabling signal from address decoder that enables the click sound when signal is low.
CLICK SOUND	Click Sound—Sound signal derived from 64V and enabled by $\overline{\text{CLICK}}$ or $\overline{\text{SCORE}}$ .
$\overline{\text{CLOCK}}$	Clock Not—Master crystal-controlled timing signal that operates at a frequency of 11.055 MHz. Raw $\overline{\text{CLOCK}}$ signal is used for generating all SYNC signals. $\overline{\text{CLOCK}}$ is used to derive the timing signals $\phi 1$ (phase 1), $\phi 2$ (phase 2), and DBE (data bus enable).
$\overline{\text{COMP BLANK}}$	Composite Blanking Not—Combination of vertical and horizontal blanking (V BLANK and H BLANK) signals. Blanking occurs during period when signal is low.
D	Data—Eight lines of signal information that provides two-way communications between the microprocessor and memory.
$\overline{\text{D-A LATCH}}$	Digital to Analog Latch Not—Signal from address decoder K2 that, when low, enables the digital buffered data input to B9 to be converted to an analog output signal.
$\overline{\text{DISPLAY}}$	Display Not—Signal from address decoder K2 that, when low, enables the writing of the playfield and score information from the playfield/score RAMs. When signal is high, data is written into playfield/score RAMs.
DIST	Distribution—Signal used for interrogation of all game switches. Signal return is SW data signal.
H	Horizontal Sync—Horizontal timing signals derived from $\overline{\text{CLOCK}}$ .
H BLANK	Horizontal Blanking—The period of time beginning with the end of a scan line and ending with the beginning of the next scan line.
HD	Horizontal Display—Four signals that are clocked at a rate of 1H and represent the maximum horizontal width of any of the game balls on a horizontal scan line.



**Table 4 Definitions of Schematic Signal Nomenclature**

Schematic Signal	Signal Description
HP	Horizontal Position—Eight information signals for location of all game balls from RAMs C7 and D7 and applied to full adders K5 and L5.
$\overline{\text{INTERRUPT REQUEST}}$	Interrupt Request Not—Signal during V Blank period that commands micro-processor to finish its present routine, then go to a special routine.
IRQ RESET	Interrupt Request Reset—Low-level enabling signal from address decoder.
LAMP	Lamp—Signal that lights the start lamps when high.
LEGIT	Legitimate—When high, data is transferred through the data bus (DB).
$\overline{\text{MATCH}}$	Match Not—A low signal that is present when vertical sync is equal to vertical position code. MATCH enables the object code to be latched at the input of the ball ROMs.
OBJ	Object—Output of motion circuit that represents the digital code for the sixteen game balls.
$\overline{\text{OBJ DISP}}$	Object Display Not—A low signal that is present when counter J3 has reached the 16th count, which represents the end of the scanning of one game ball on one scan line.
$\overline{\text{OBJ BALLS}}$	Object Balls Not—Serial data that represents game balls 0 through 15 and is applied to the composite video summing circuit.
PA	Position Address—During vertical blanking, the four signals are micro-computer address bits BA0 through BA3. During horizontal blanking, these signals are horizontal sync 16H, 32H, 64H, and 8H. During scan time, these signals are object code bits OBJ1 through OBJ4.
PFD	Playfield Display—Address inputs to the playfield/score ROM.
$\overline{\text{POS H}}$	Horizontal Position Not—A low enabling signal from address decoder that enables horizontal position RAMs C7 and D7 to write in horizontal position data. When signal is high, written-in data is read out of RAMs.
$\overline{\text{POS V}}$	Vertical Position Not—Enabling signal from address decoder that enables vertical position RAMs E7 and F7 to write in vertical position data. When signal is high, written-in data is read out of RAMs.
PSA	Position Sync/Address—Address signals BA0 through BA3 during vertical blanking period and is sync signal 16H, 32H, 64H, and 8H during non-vertical blanking period.
Q BALL	Cue Ball—Signal applied to video summing circuit to produce a white video cue ball.

Table 4 Definitions of Schematic Signal Nomenclature

Schematic Signal	Signal Description
$\overline{\text{RAMS}}$	RAMs Not—Low-level enabling signal from the address decoder that enables the scratch pad RAMs.
$\overline{\text{RE}}$	ROM Not—Low-level enabling signal from the address decoder that enables program memory ROMs as instructed by the microprocessor address code.
$\overline{\text{RW}}$	Read/Write Not—When high data is read out of a RAM and low when data is written into a RAM.
$\overline{\text{SCRATCH}}$	Scratch Not—Low-level enabling signal from the address decoder that enables the scratch sound.
SCRATCH SOUND	Scratch Sound—Sound derived from BA0 signal and enabled by SCRATCH.
$\overline{\text{SCORE}}$	Score Not—Low-level enabling signal from address decoder that enables the score sound.
SCORE SOUND	Score Sound—Short duration sound that rapidly changes from low to high frequency. Enabled by $\overline{\text{SCORE}}$ .
$\overline{\text{START LIGHT}}$	Start Light Enable Not—Low-level enabling signal from address decoder that results in lighting the START LEDs.
SW	Switch—Data signal to the microcomputer that is low when switch is open and high when switch is closed.
$\overline{\text{SWITCHES}}$	Switches Interrogation Enable Not—Enabling signal from the address decoder. Signal is low when game switches are interrogated.
V	Vertical Sync—Vertical timing signal derived from CLOCK.
V BLANK	Vertical Blanking—Vertical timing signal derived from CLOCK that represents period from end of last horizontal trace to the <i>beginning</i> of the first horizontal trace. $\overline{\text{V BLANK}}$ represents time while horizontal lines are being traced.
VD	Vertical Data—Output of vertical line comparator of the motion circuit that instructs the ball ROMs which line of the ball picture is being scanned.
VP	Vertical Position—Digital code from vertical position RAMs that is compared to vertical sync at inputs to full adders E6 and F6.
$\emptyset$	Phase—Two timing signals derived from $\overline{\text{CLOCK}}$ that are used as the basic timing signals for the microprocessor.

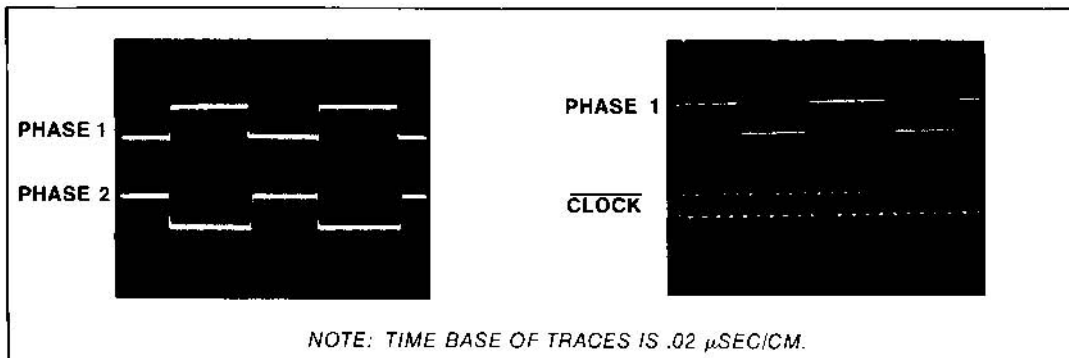
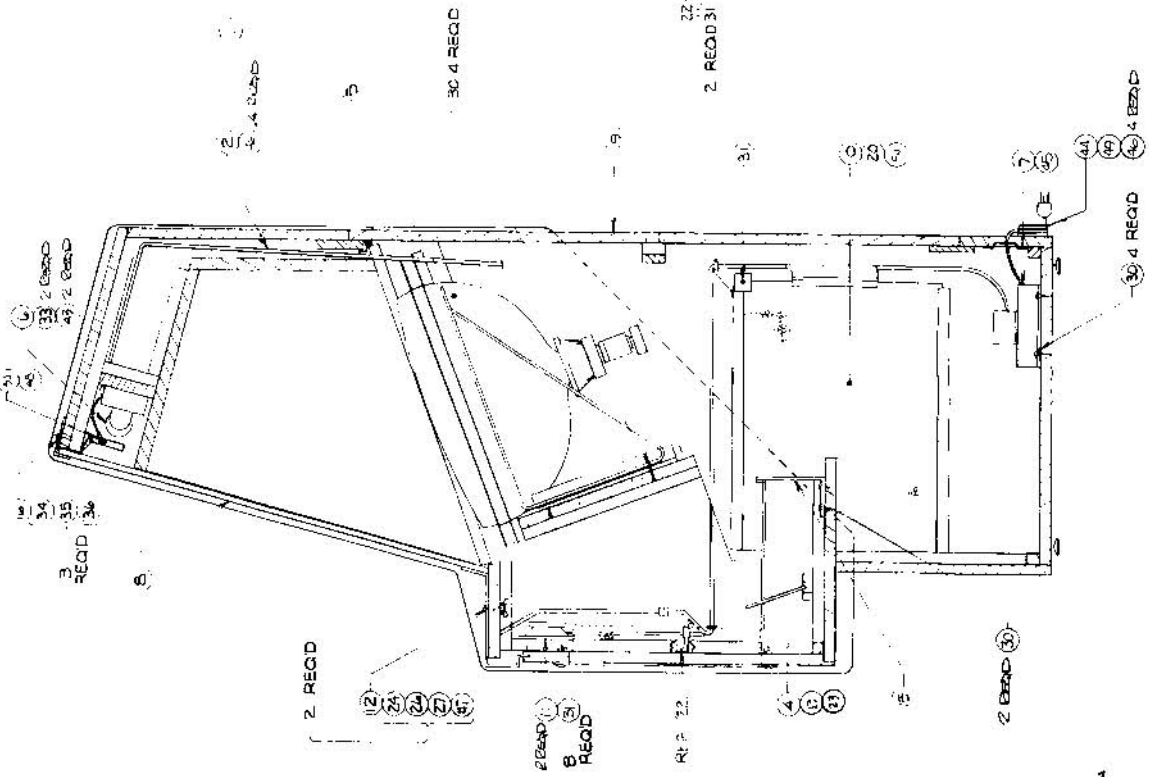
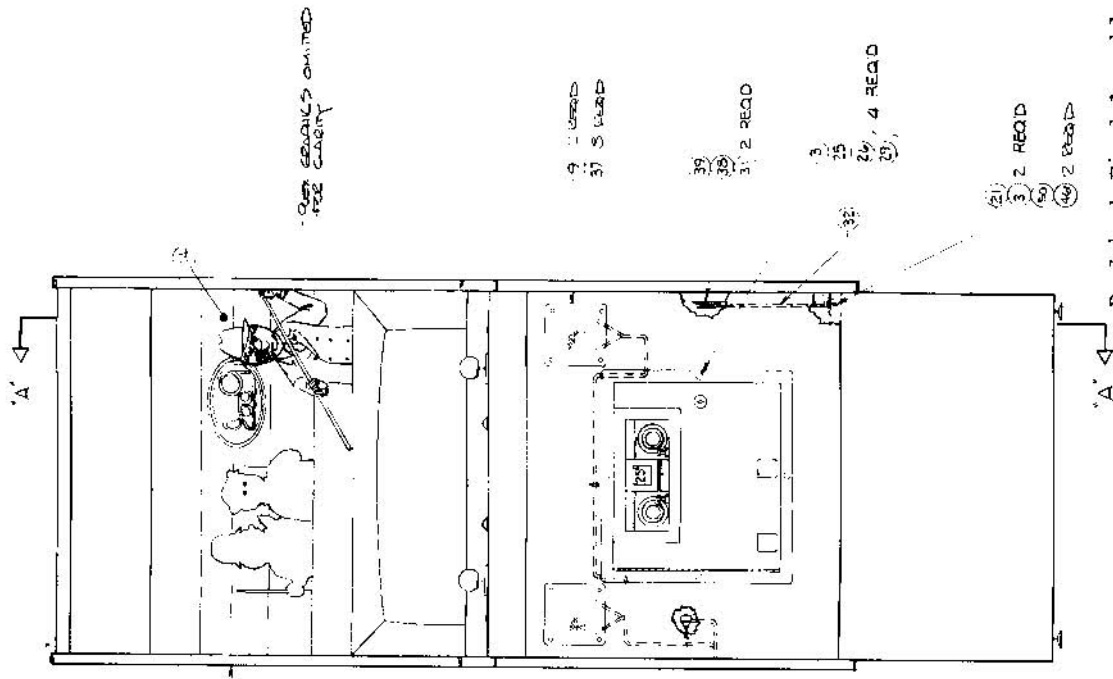

Figure 24 Oscilloscope Picture of  $\theta 1$ ,  $\theta 2$ , and  $\overline{\text{CLOCK}}$



Poolshark Final Assembly  
A007450-01 C  
Figure 1



Poolshark Final Assembly  
Parts List  
Figure 1

A007450-01  
Sheet 1 Of 2

Item	Part Number	Qty.	Description
1	A006195-XX	1	Assembly, Cabinet with Graphics
2	A007651-01	1	Assembly, Harness
			NOTE: Items 3 and 3A may be ordered together as assembly part number A009083-01.
3	A006794-01	1	Assembly, Coin Door - See Figure 2
3A	A006921-01	1	Assembly, Coin Door Harness
4	006316-01	1	Assembly, Coin Box
5	A005427-01	1	Assembly, TV Monitor - See Figure 3
6	A007458-01	1	Assembly, Fluorescent Light - See Figure 4
7	A007197-01	1	Assembly, Electronics Tray (Type "B") - See Figure 5
8	007449-01	1	Front Plexiglass W/Graphics
9	000869-01	2	Speaker Grill
10	A007354-01	1	Assembly, R.F. Shield - See Figure 6
11	48-004	2	Speaker
12	A007451-01	1	Assembly, Control Panel - See Figure 7
13	006317-01	1	Coin Box Lid
14	007452-01	1	Bezel, Cardboard W/Graphics
15	006870-01	1	Bracket, Coin Box Lock
16	003053-01	1	Plexiglass Retainer
17	006305-01	1	Poly Bag, Printed
18	TM-083	1	Tech Manual
19	A007454-01	Ref	Assembly Rear Door
20	A006281-01	1	Assembly P.C. Board - See Figure 9
21	A006449-01	1	Assembly, On/Off Switch
22	A006548-01	1	Assembly, Test Switch
23	006545-01	1	Coin Box Handle
24	75-55 20B	2	Carriage Bolt #4-20 x 1 1/4" Lg.
25	75-55 16B	4	" " #4-20 x 1" Lg.
26	75-035S	6	Washer Flat #4
27	75-045	2	Washer Split-Lock #4
28	72-6824	8	Screw, Sht. Met. Pan Hd. Phil #8 x 1 1/2" Lg.
29	75-990505S	4	Nut, Lock, Nylon, Shallow Pattern
30	72-6812	10	Screw, Sht, Met, Pan Hd, Phil., #8 x 3/4" Lg.
31	72-6608	28	Screw, Sht, Met, Pan Hd, Phil., #6 x 1/2" Lg.
32	A007717-01	1	Power Switch Harness Assy
33	72-6620	2	Screw, Sht, Met, Pan Hd, Phil., #6 x 1 1/2" LG.
34	75-99090006	3	Well-Nut Insert #10-32
35	82-8014B	3	Screw, Bottom Hd., Socket, #10-32 x 7/8 Lg, Blk
36	75-07021	3	Washer, Nylon, Blk, #10



Final Assembly  
Parts List  
Figure 1

A007450-01  
Sheet 2 Of 2

Item	Part Number	Qty.	Description
37	73-77004	8	Pop Rivet, Alum., 3/16 x .63 Lq.
38	68-002	1	Interlock Switch
39	000268-02	1	Bracket, Interlock Switch
40	006319-01	1	Copyright Decal
41	005233-01	1	Rear Door Seal
42	006199-XX	1	Shipping Container
43	75-031S	2	Washer, Flat Reg. Pattern #10
44	A007784-01	1	Power Cord Strain Relief
45	46-201202	2	2 AMP Fuse
46	72-6610S	20	Screw, Sht. Met., #6 x 5/8" Lg.
47	75-935	2	Wingnut #4-20
48	78-6601216	A/R	Alum. Foil Tape (Approx. 10")
49	78-25001	1	Screwdown Tie Wrap
50	007103-01	1	On/Off Switch Cover
51	A007461-01	1	R.F. Box Assy

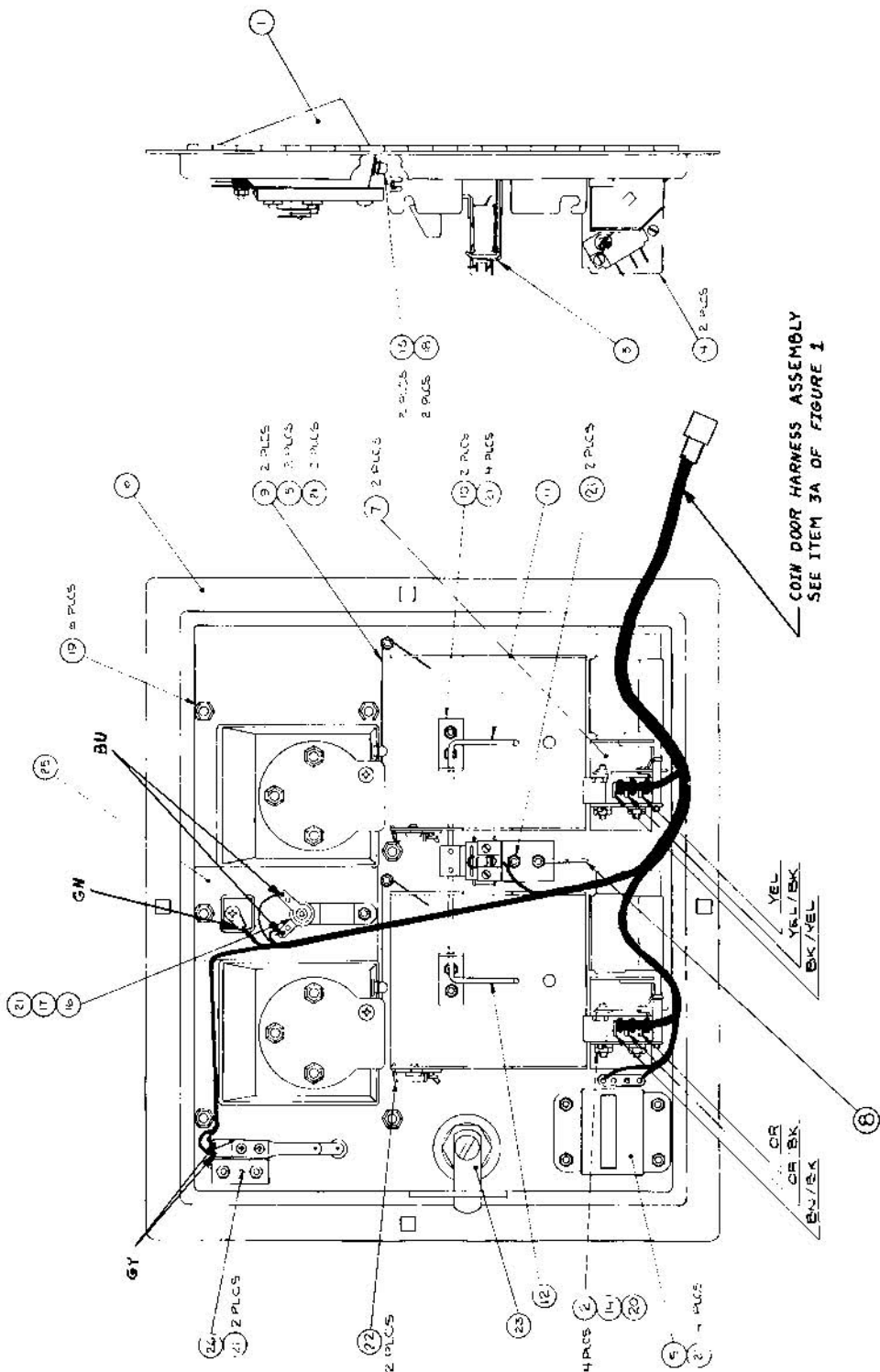

Coin Door Assembly  
A006794-01 E  
Figure 2



Coin Door Assembly  
Parts List  
Figure 2

A006794-01

Item	Part Number	Qty.	Description
1	A007637-01	1	Front Bezel Asm.
2	75-9165	4	Nut 6-32
3	A007639-01	1	Coin Lock-Out Asm.
4	A007640-01	2	Coin Switch Asm.
5	A002465-01	1	Coin Counter Asm.
6	004320-01	1	Coin Door Weldment
7	004341-01	2	Secondary Coin Chute
8	004344-01	1	Key Loop
9	004340-01	2	Spring - Return
10	004337-01	2	Bracket, Wire Form
11	004338-01	1	Lock-Out, Wire Form, R.H.
12	004336-01	1	Lock-Out, Wire Form, L.H.
13	004326-01	2	Button, Scavenger
14	75-046	4	Lck Washer #6
15	006904-01	2	Spacer
16	007359-01	1	Lamp Socket
17	70-11-47	1	Lamp
18	73-3008	2	Retaining "C" Ring, Truarc #5103-25
19	75-9914001	6	Self-Threading Nut, Tinnerman #SR188006
20	75-0268	4	Washer #6
21	75-00516	13	Keplnut, Style 842, Stl, 6-32
22	008629-01	2	Spring
23	71-2118	1	Lock Assembly, Hudson Lock
24	71-122500	2	Coin Mech., 25c
25	007753-01	1	Plate, Anti-Probe
26	A007638-01	1	Switch Assembly - Slam



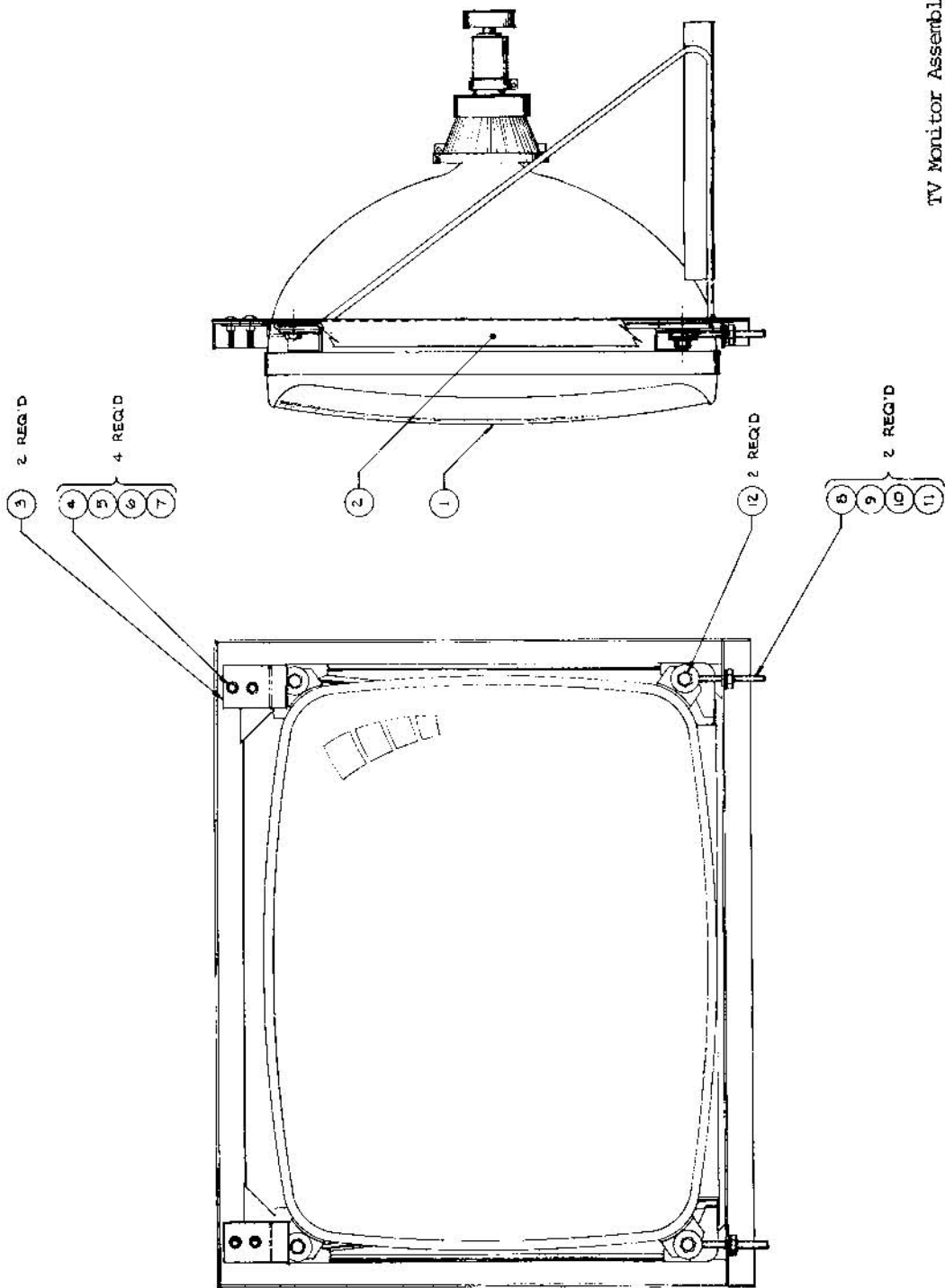

TV Monitor Assembly  
 A005427-01 C  
 Figure 3



TV Monitor Assembly  
Parts List  
Figure 3

A005427-01

Item	Part Number	Qty.	DESCRIPTION
1	92-007	1	Monitor, Motorola, 23" Dia., XM-701-10
2	A005305	1	Monitor Support Weldment
3	005377	2	Bracket, Monitor
4	75-5112	4	Carriage Bolt, #10-24 x 3/4" Lg.
5	75-010S	4	Washer, Flat, #10
6	75-040	4	Washer, Split-Lock, #10
7	75-911S	4	Nut, Hex Hd., #10-24
8	82-406	2	Eyebolt, #4-20 x 2" Lg.
9	75-015S	2	Washer, Flat #4"
10	75-045	2	Washer, Split-Lock, #4"
11	75-915S	2	Nut, Hex Hd., #4-20
12	72-6012	2	Screw, S.M. #10 x 3/4

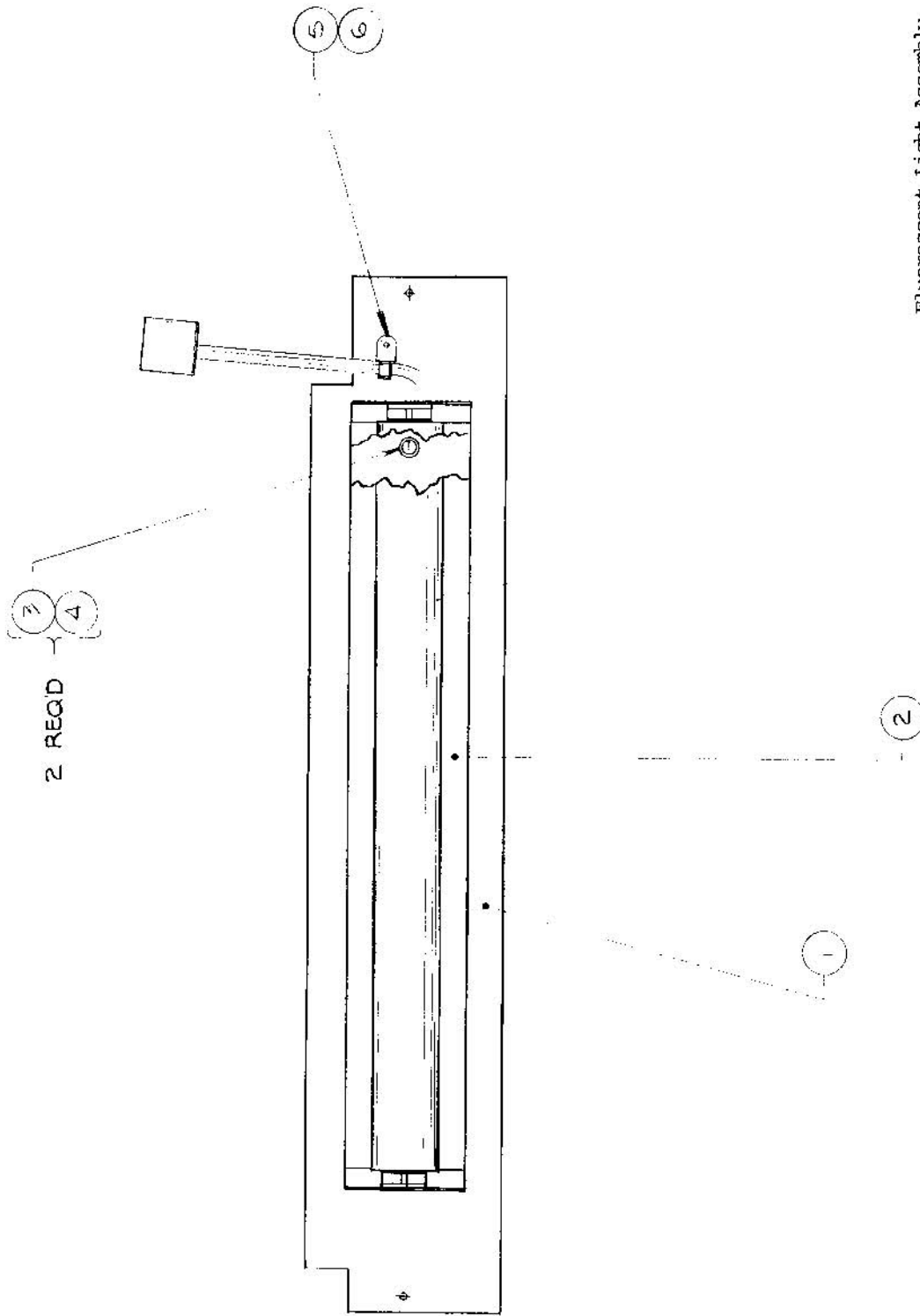

Fluorescent Light Assembly  
A007458-01 B  
Figure 4



Fluorescent Light Assembly  
Parts List  
Figure 4

A007458-01

Item	Part Number	Qty.	Description
1	006161-01	1	Board, Mount, Light
2	A006917-07	1	Fluorescent Light Assy (100" Lq. Harness)
3	75-6808	2	Screw Sht Met #8 x 1/2 Lg
4	75-018S	2	Washer, Flat, Plain, Reg. Pat. #8
5	72-6610	1	Screw, Sht. Met., #6 x 5/8" Lg.
6	78-25001	1	Screw, Down, Tie Wrap

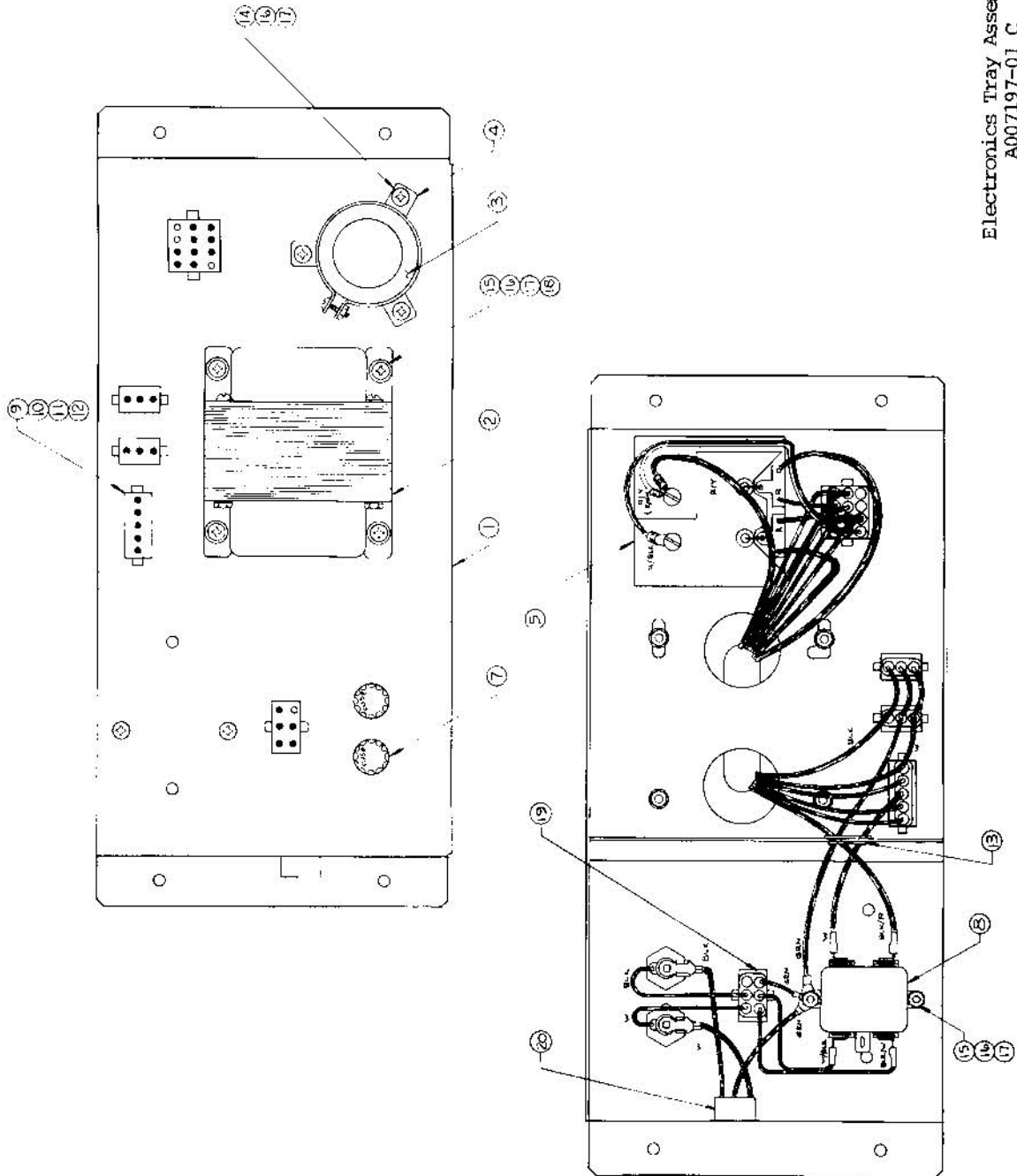

Electronics Tray Assembly  
 A007197-01 C  
 Figure 5



Electronics Tray Assembly  
Parts List  
Figure 5

A007197-01

Item	Part Number	Qty.	Description
1	A009266-01	1	Power Supply Base Weldment Assembly
2	A006886-01	1	Transformer Termination Assembly
3	29-053	1	Cap., Sprague Electrolytic 26,000uf @ 15V
4	78-70501SC	1	Brkt., Cap. Mtg. Sprague #4586-48
5	A006555-01	1	P.C. Board Rectifier
6			
7	79-4411003	2	Fuse Holder, Panel Mounting
8	41-2003	1	Filter, Power Line, 5 AMP
9	A006958-01	A/R	Volt Sel Block 95V
10	A006958-02	"	Volt Sel Block 110V
11	A006958-03	"	Volt Sel Block 205V
12	A006958-04	"	Volt Sel Block 220V
13	78-2708	1	Grommet, Plastic
14	72-1808S	3	Screw Pan Hd., #8-32 x 1/2" Lg.
15	72-1812S	6	Screw Pan Hd., #8-32 x 3/4" Lg.
16	75-058	9	Washer, Lock, Internal Star #8
17	75-918S	9	Nut Hex #8
18	75-018S	4	Washer Flat #8
19	A007192-01	1	Power Switch Termination
20	A007444-01	1	Power In Harness





RF Shield Assembly  
Parts List  
Figure 6

A007354-01

Item	Part Number	Qty.	Description
1	006549-01	1	Printed Circuit Board
2	79-517222	1	Connector, 44 Pin P.C. Mount
3	27-250104	6	Cap, Cer Disc, 0.1uf, 25V
4	41-3003	5	Inductor, 100uh
5	52-004	8	Jumper, 1/3 Center
6	52-003	2	Jumper, 1/6 Center
7	27-A250104	6	Cap, Cer Disc, 0.1uf, 25V







Control Panel Assembly  
Parts List  
Figure 7

A007451-01

Item	Part Number	Qty.	Description
1	007448-01	1	Control Panel with Graphics
2	001856-01	2	Bezel Switch
3	62-002	2	Switch, Licon with LED
4	A007647-01	2	Assy, Control Stick - See Figure 8
5	007648-01	2	Bezel Control Stick
6	72-1208S	8	Screw, Mach. Pan Head, #2-56 x 1/2" Lg. (Steel)
7	A007657-01	1	Assy, Harness
8	99-060020	2	Bezel, Joystick

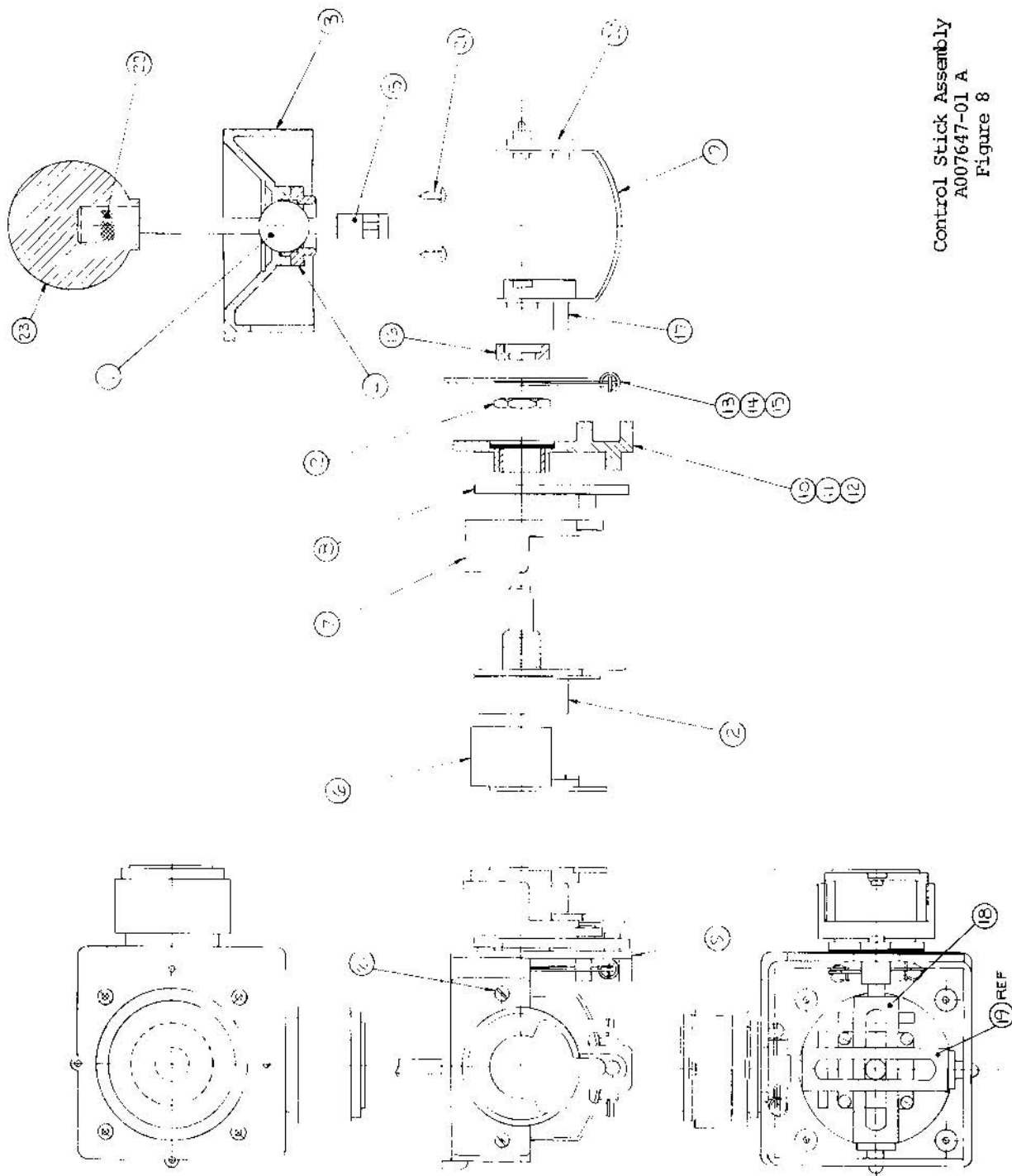

Control Stick Assembly  
 A007647-01 A  
 Figure 8



Control Stick Assembly  
Parts List  
Figure 8

A007647-01

Item	Part Number	Qty.	Description
1	A007476-01	1	Ball & Stick Assembly
2	19-9024	2	Potentiometer
3	99-060001	1	Housing #850-015
4	99-060002	1	Ball Retainer #850-017
5	99-060016	1	Stick Guide #850-028
6	99-060003	2	Pot Rear Housing #850-006
7	99-060004	2	Pot Front Housing #850-005
8	99-060022	2	Trimless Lever #850-033
9	99-060007	1	Pot Mounting Plate #1 #850-020
10	99-060008	1	Pot Mounting Plate #2 #850-021
11	99-060006	2	Brass Bushing #850-008
12	99-060005	2	Washer, Flat, 5/8 O.D. x 3/8 I.D. x .025 Thk #500-054-1
13	99-060011	4	Dog Stop #850-007
14	99-060012	2	Washer Teflon, 1/2 O.D. x 1/4 I.D. x .005 Thk #850-010
15	99-060019	2	Spring Extension #500-027
16	99-060010	2	Spacer #850-024
17	99-060013	2	Coupling #850-025
18	99-060014	1	Inside Bail #850-026
19	99-060015	1	Outside Bail #850-030
20	99-060018	2	Bail Pivot Hinge #850-027
21	75-6204	8	Screw, #2, Sheetmetal
22	78-13002	A/R	Loctite #88-21
23	73-822	1	Ball Knob

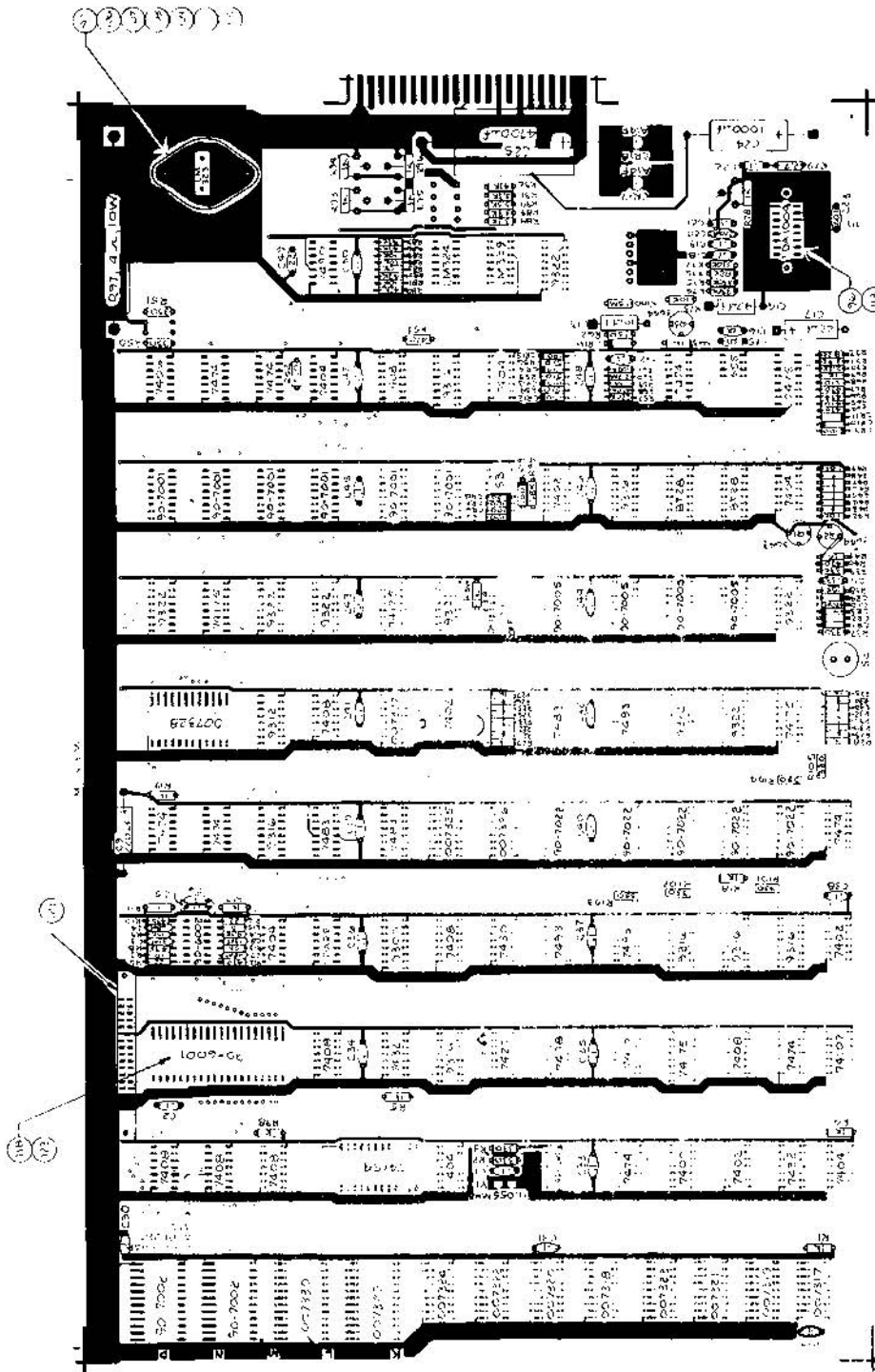

Poolshark PCB Assembly  
 A006281-01 A  
 Figure 9



Poolshark PCB Assembly  
Parts List  
Figure 9

A006281-01  
Sheet 1 Of 4

Item	Part Number	Qty.	Description
1	006282-01	1	PRINTED CIRCUIT BOARD
2	10-5100	2	RES., CARBON, 5%, 1/4W, 10 OHM R7,15
3			
4	10-5102	28	" " " " 1K OHM R1,4,5,11,17,18,19,20-35,36,41,63,69,98
5	10-5103	7	" " " " 10K OHM R9,13,73,81,83-85
6	10-5104	1	" " " " 100K OHM R61
7	10-5105	1	" " " " 1M OHM R59
8	10-5153	1	" " " " 15K OHM R38
9	10-5182	9	" " " " 1.8K OHM R42-49,99
10	10-5220	2	" " " " 22 OHM R6,16
11	10-52P7	1	" " " " 2.7 OHM R79
12	10-5222	1	" " " " 2.2K OHM R70
13	10-5224	1	" " " " 220K OHM R57
14	10-5225	1	" " " " 2.2M OHM R60
15	10-5331	11	" " " " 330 OHM R50,51,2,3,37,62,101-105
16	10-5332	4	" " " " 3.3K OHM R88-91
17	10-5392	1	" " " " 3.9K OHM R71
18	10-5333	1	" " " " 33K OHM R39
19	10-5334	3	" " " " 330K OHM R74,75,77
20	10-5471	8	" " " " 470 OHM R10,12,40,53,64-67
21	10-5472	2	" " " " 4.7K OHM R8,14
22	10-5473	5	" " " " 47K OHM R80,82,86,87,92
23	10-5474	1	" " " " 470K OHM R58
24	10-5822	1	" " " " 8.2K OHM R72
25	10-5823	1	RES., CARBON, 5%, 1/4W, 82K OHM R76
26	19-805W4P0	1	" " " " 10W, 4 OHM R97



Pool Shark P.C. Bd. Assembly  
Parts List  
Figure 9

A006281-01  
Sheet 2 Of 4

Item	Part Number	Qty.	Description	
27	19-315102	5	TRIMPOT, 1K	R78,93-96
28	10-5511	4	Res, Carbon, 5%, 1/4W, 510 OHM	R54-56,68,52
29	10-5155	1	Res, Carbon, 5% 1/4W, 1.5 MEG OHM	R100
32	24-250475	1	CAP., ELECTROLYTIC, 4.7uf, 25V	C14
33	24-250106	1	" " 10uf, 25V	C13
34	24-250226	1	" " 22uf, 25V	C17
35	24-250227	1	" " 220uf, 25V	C9
36	24-250108	1	" " 1000uf, 25V	C24
37	24-250478	1	" " 4700uf, 25V	C25
40	27-250102	1	CAP, CERAMIC DISC .001uf, 25V	C23
41	27-250103	2	" " " .01uf, 25V	C15,16
42	27-250334	1	" " " .33uf, 25V	C11
43	27-250104	29	" " " .1uf, 25V	C1,2,5,6,12,18,1 21,22,30-48,50
44	27-250224	1	" " " .22uf 25V	C49
46	28-101330	2	CAP, DIPPED MICA, 33pf, 100V	C3,8
47	28-101680	2	" " " 68pf, 100V	C4,7
48	28-101221	1	" " " 220pf, 100V	C20
49	28-101471	1	" " " 470pf, 100V	C10
54	31-A14F	2	DIODE, A14F	CR17,18
55	31-1N100	10	" 1N100	CR5-9,12-15,19
56	31-1N914	7	" 1N914	CR1-4,10,11,16
61	33-2N3643	1	TRANSISTOR, 2N3643	Q1
62	33-2N3644	2	" 2N3644	Q2,3
67	37-7400	1	INTEGRATED CIRCUIT, 7400	D2
68	37-7402	4	" " 7402	A4,C2,J6,F8
69	37-7404	6	" " 7404	A2, J2,M4,B8,L9,H9
70	37-7408	9	" " 7408	M2,N2,P2,C3,F3,L3, J4,L6,K9



Poolshark PCB Assembly  
Parts List  
Figure 9

A006281-01  
Sheet 3 Of 4

Item	Part Number	Qty.	Description
71	37-7410	1	" " 7410 E3,
72	37-7406	1	" " 7406 P9
73	37-7427	1	" " 7427 H3
74	37-7430	1	" " 7430 H4
75	37-7432	2	" " 7432 B2, K3
76	37-7474	8	" " 7474 A5, B3, E2, N5, P5, D9, M9, N9
77	37-7475	1	" " 7475 B9
78	37-7483	4	" " 7483 K5, L5, E6, F6
79	37-7490	1	" " 7490 L10
80	37-7493	2	" " 7493 E4, F4
81	37-74107	1	" " 74107 A3
82	37-74154	1	" " 74154 K2
83	37-74175	4	" " 74175 D3, B6, K7, N7
84	37-8T28	2	" " 8T28 C8, D8
88	37-9300	1	" " 9300 K4
89	37-9312	1	" " 9312 M6
90	37-9316	7	" " 9316 J3, B4, C4, D4, M5, E8, J9
91	37-9321	1	" " 9321 J7
92	37-9322	7	" " 9322 C6, D6, B7, L7, M7, P7, F10
93	37-555	1	" " 555 C9
94	37-LM324	1	" " LM324 J10
95	37-LM339	1	" " LM339 H10
96	37-TDA -1004	1	I.C. AUDIO TDA-1004 B10
97	37-LM323	1	REGULATOR N10
98	37-74H04	1	I.C. 74H04 F2
102	62-001	1	SWITCH, SPST, MOMENTARY S2
103	66-114PIT	2	" SPST, x4 DIP S1, S3





Poolshark PCB Assembly  
Parts List  
Figure 9

A006281-01  
Sheet 4 of 4

Item	Part Number	Qty.	Description
106	72-1608C	2	SCREWS, PAN HD. PHIL, 6-32x $\frac{1}{2}$ LG, CRFS
107	75-016	2	WASHER, FLAT #6
108	75-056	2	" LOCK, 1/4T STAR, #6
109	75-916C	2	NUT, HEX, #6-32 CRFS
112	78-06001	1	HEATSINK (LM323)
113	78-060 22	1	" (TDA-1004)
114	78-13016	AR	CEMENT (TDA-1004 HEATSINK)
115	78-16005	1	SILPAD (LM323)
118	79-42040	1	SOCKET, 40 PIN, Med. INSERTION N3
121	79-14002	1	HEADER, 34 PIN
122	90-105	1	CRYSTAL, 11.055 MHZ Y1
123	90-6001	1	INTEGRATED CIRCUIT N3
124	90-6002	1	" " N4
125	90-7002	2	RAM, 6810L P1,N1
126	90-7001	6	" 2102-1 J8,K8,L8,M8,N8,P8
127	90-7005	4	" 82S25 C7,D7,E7,F7
128	90-7022	5	" 82S17 B5,C5,D5,E5,F5
129			
130	007325	1	PROM, BALL PICTURE 1 J5
131	007326	1	PROM, BALL PICTURE 2 H5
132	007327	1	PROM, BALL WINDOW K6
133	007328	1	PROM, CHARACTER N6
134	007329	1	PROGRAM ROM 1 K1
135	007330	1	PROGRAM ROM 2 L1