

DINE LIKE A SWINE!

PIGGOUT™



SERVICE
MANUAL

LELAND

Troubleshooting

A Note About Power

DC Power

The microprocessor in this machine operates most efficiently when the power supply is providing a steady +5.00 VDC to 5.05 VDC. When checking the DC power, always put your leads across the +5 VDC test points on the top board (**NOT** at the power supply, DC input connector or any IC) and be sure that the +5 volt supply is between +5.00 VDC and +5.05 VDC. Also, be sure that there is less than .005 volts AC riding on the +5 volt line. If you do find AC on the DC line, inspect the filter capacitor or the rectifier on the power supply. Low voltage and AC on the DC lines are the main causes of the following problems:

- "Garbage" on the monitor screen
- Computer freeze-up
- Coin or coin meter malfunction
- A variety of seemingly unrelated problems

AC Power

Connect this game only to a grounded three-wire outlet which provides between 108 and 132 volts AC. If you have only a two-wire outlet, we recommend that you hire a licensed electrician to install a grounded outlet. This will reduce the possibility of a player receiving a shock. The possibility exists that players may receive an electrical shock if this system is not properly grounded.

Our Service Department

For parts, service, and technical information, first contact your authorized Leland Corporation Distributor. If additional technical aid is required, please contact the Leland Corporation Customer Service Department at (619) 562-7000, Monday through Friday, 8:00 a.m. to 5:00 p.m. Pacific Time.

To provide you with the quickest possible response to your questions, please have the following information ready when you call:

- Your game name and serial number
- Any reference materials and a list of observations

NOTE: Schematics for this game are available in the form of a service manual. Contact our service department and order publication number B-703-00007-00.

Troubleshooting Tips

General Troubleshooting

Monitor screen filled with "garbage"—

- Check power supply voltages.
- Check closed switches on the control panel or coin door.
- Look for loose connections, loose ICs, or bent pins on the board.
- Measure the voltage on Pins 3, 4, 5, 6, & 7 on Connector P-4. If the voltage is less than +5 VDC, suspect U114 or U119.

No sound—

- Check for loose connections.
- Low +12 VDC supply.
- Bad speaker or volume pot.

No control or function switches (Includes coin switches)—

- Check all connections (especially ground).
- Check wire continuity between board and switch.
- Look for closed or broken switches.
- Check the input buffers (see "Buffers" below).

Monitor Troubleshooting

No picture—

- Check all power connections.
- Check monitor fuses.
- Check all video connections for continuity.

Sync problems—

- Check sync and ground connections (see wiring diagrams on Pages 18 - 20).
- Check sync polarity.
- Check the video output buffer.

Buffers

An input or output (I/O) buffer is the component that connects the actual game computer to the outside world. It is for that reason that it is the part most likely to fail. Check the following list when attempting to isolate possible problems.

Important Note: Any unauthorized board repair or attempted repair will void your warranty! Refer to the Leland Corporation Limited Warranty statement at the back of this manual for restrictions and or limitations.

Troubleshooting Tips (cont'd)

M = Main Board

I/O = Multi-Function Board

Problem Area	Component	PCB Location
Video (Color or Sync)	7405 or 74S05	M-U24
Player Controls and/or Coin Controls	150Ω resistor pack or 74LS257	See wiring diagrams for specific switch
Audio (Bad Channel)	7524 or 7533	I/O-U46 (ch 0) through U51 (ch 5) or I/O-U64
	TDA 2002	M-U122

About Mechanical Coin Counters

We have not installed mechanical coin counters on this game for the following reasons:

- The bookkeeping program for this game is extremely accurate and includes not only the number of coins dropped and the dollars earned, but also keeps track of the number of tests and coins in a given period. (See "Bookkeeping" in the Diagnostics Section.)
- Mechanical coin counters can produce an inductive "kick" that could damage circuit board components, checkerboard video being the most common problem. Should the checkerboard video problem occur, observe the "NMI not" signal on the master Z80 chip (pin 17). If a low output is observed, try replacing U114 (74LS08) and/or U119 (74LS257).

If your situation required mechanical coin counters, please use the follow diagram. (Diodes may be 1N4001 to 1N4004.)

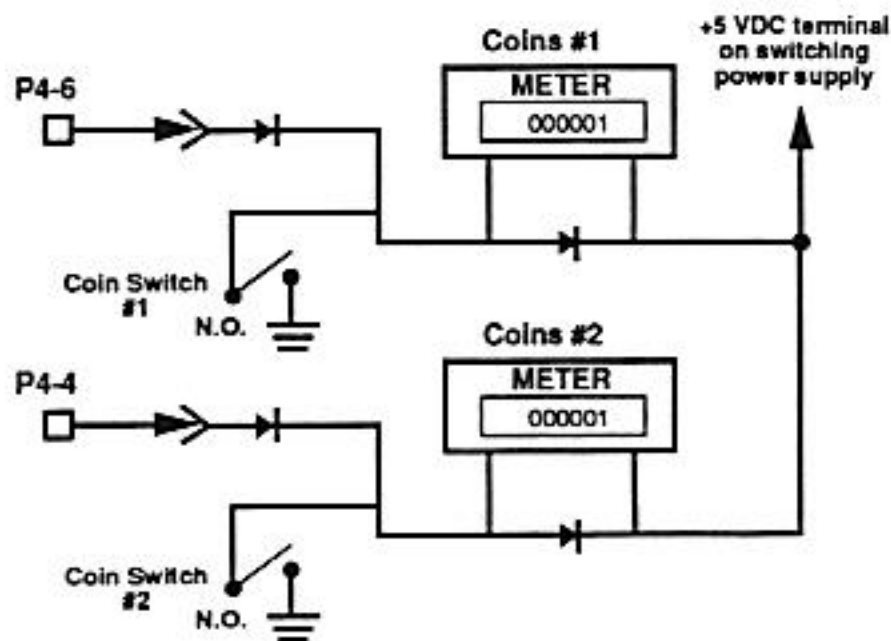

Cabinet Wiring Diagram

AC Power
 108 - 132 VAC
 2.5 A Max

DC Power
 +5 VDC @ 11A
 +12 VDC @ 2A
 -5 VDC @ 1A

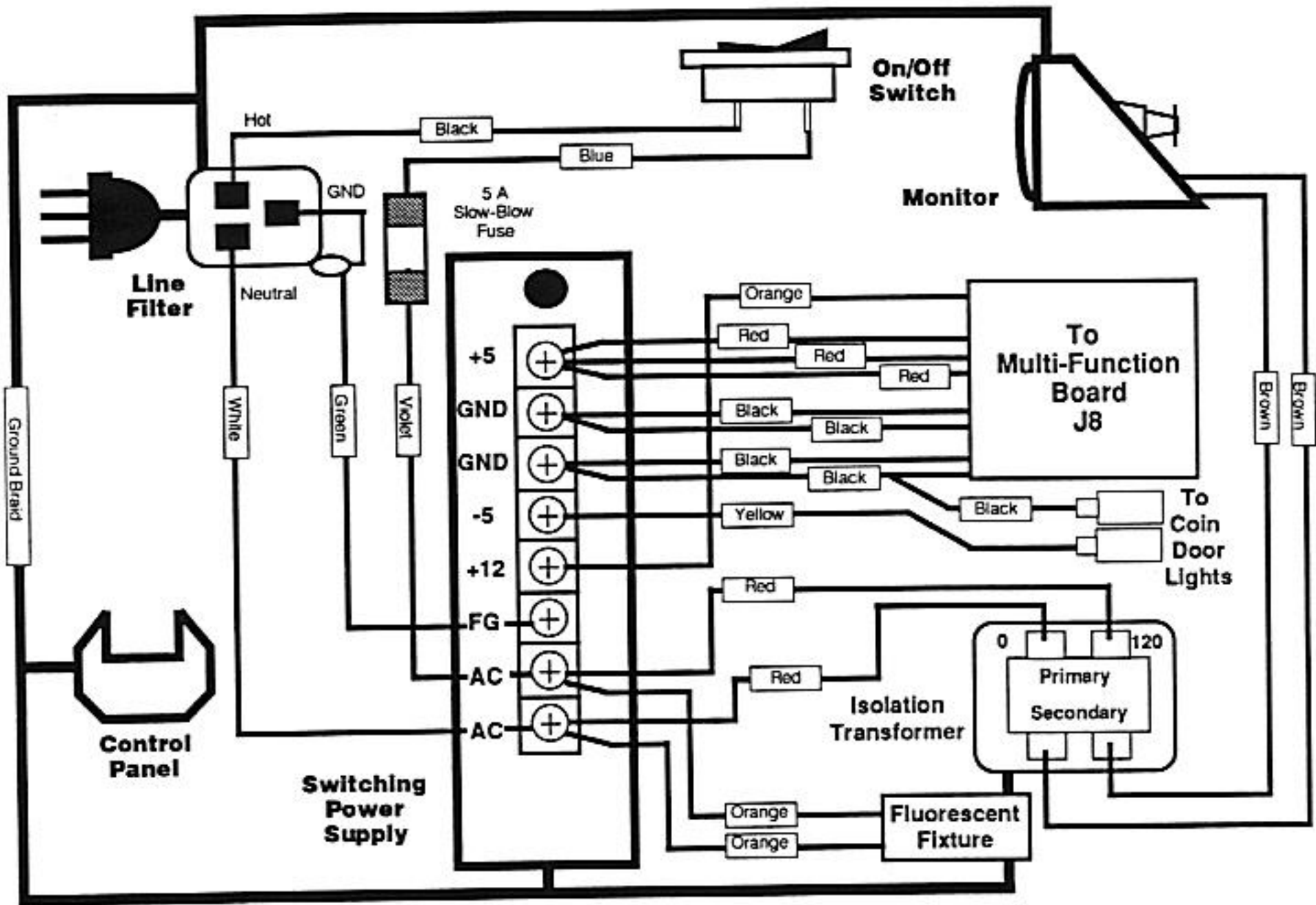

Player Control Wiring

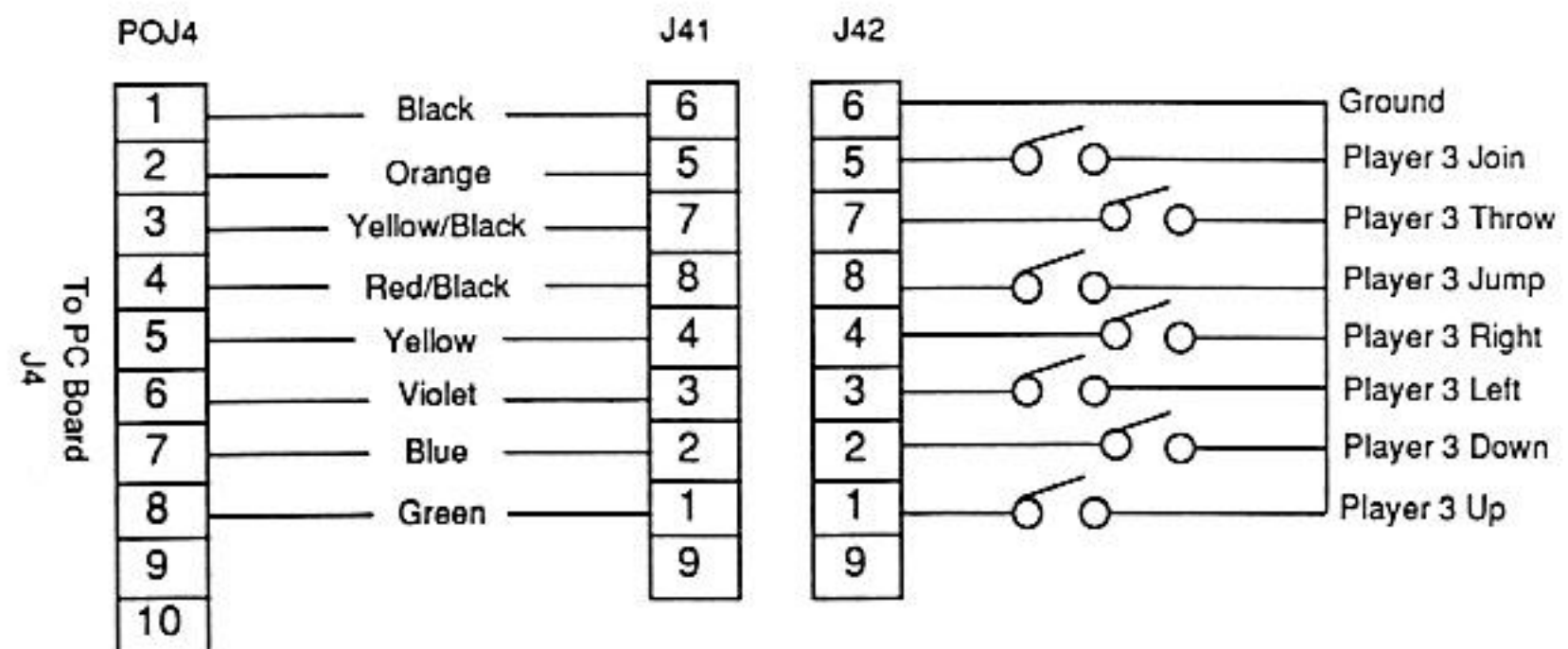
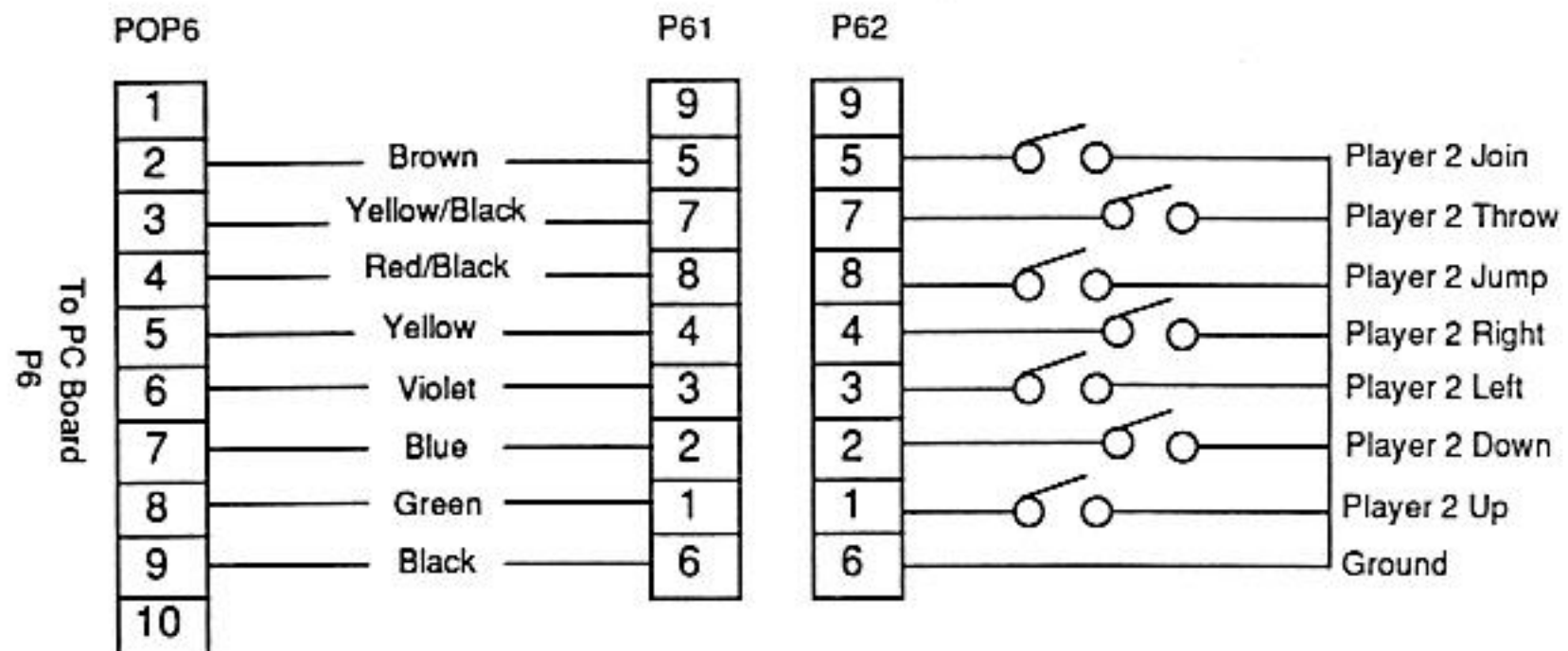
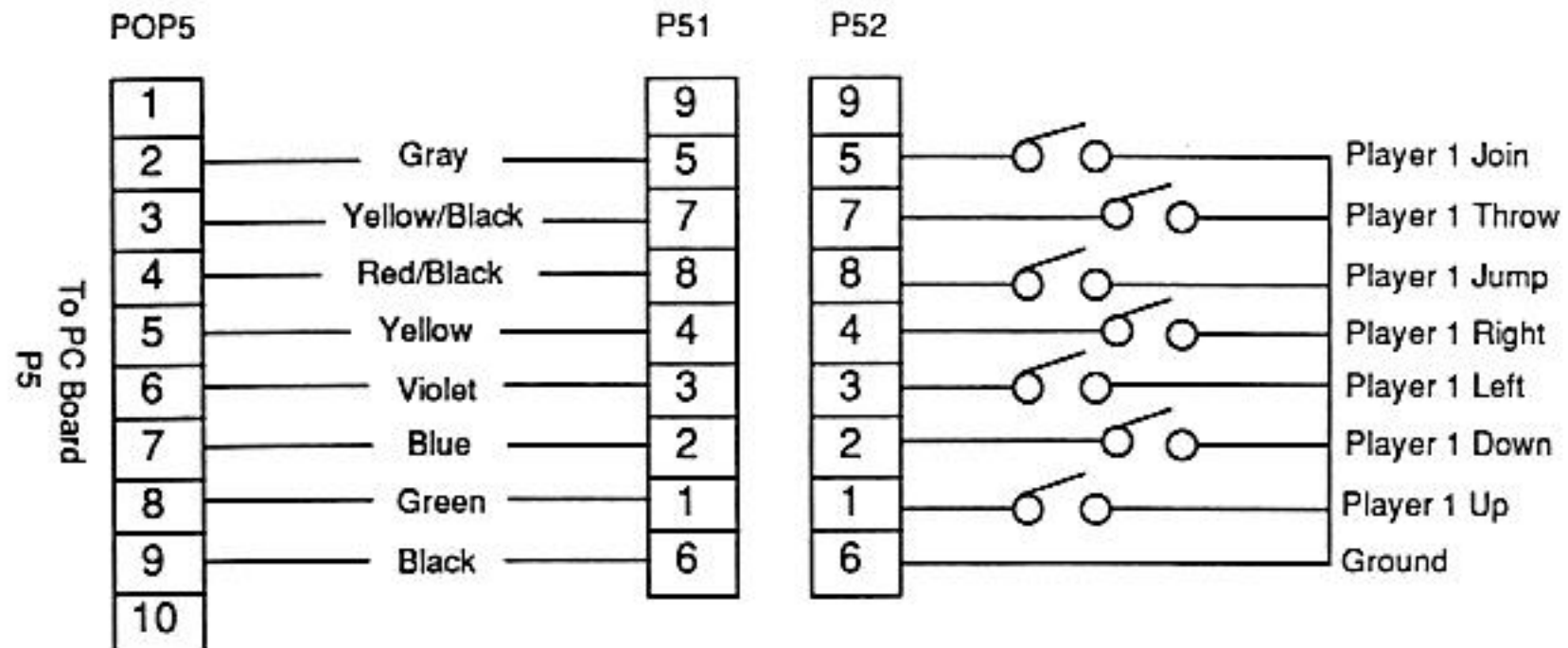

Coin, Video, Power Wiring

