

PAC-MANIA

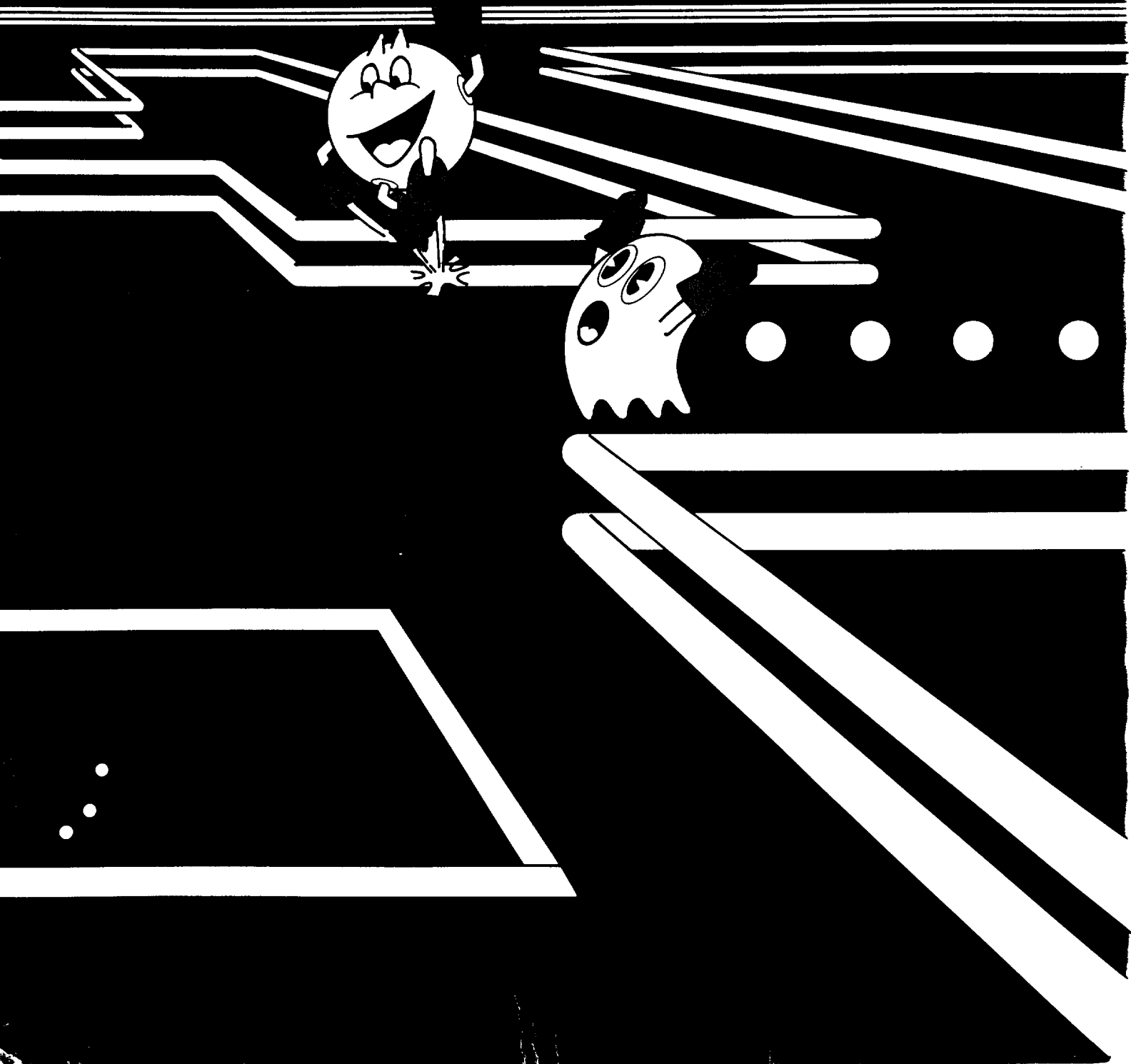

For technical assistance:

If reading through this manual does not lead to solving a maintenance or repair problem, call TELEHELP® at one of these Atari Games Customer Service offices:

UNITED STATES

Atari Games Corporation
California Customer Service Office
737 Sycamore Drive
P.O. Box 361110
Milpitas, CA 95035
Fax (408) 434-3945
Telex 5101007850

☎ (408) 434-3950
(Monday-Friday, 7:30-4:00 pm Pacific Time)

EUROPE

Atari Games Ireland Limited
European Customer Service Office
Tipperary Town, Ireland
Fax 062-51702
Telex 70665

☎ 062-52155
(Monday-Friday, 9:00-5:30 pm GMT)

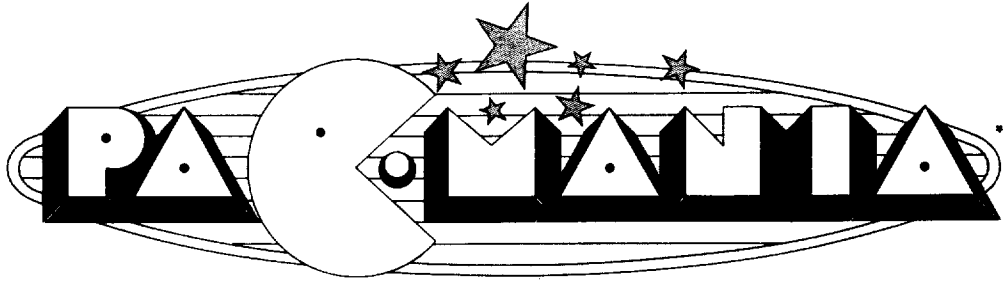

Operators Manual

with Illustrated Parts Lists



**Pac-Mania is engineered and designed by Namco Ltd.
Manufactured by Atari Games. Trademark and © Namco 1987.*

© 1987 by Atari Games Corporation

All rights reserved

No part of this publication may be reproduced by any mechanical, photographic, or electronic process, or in the form of a phonographic recording, nor may it be stored in a retrieval system, transmitted, or otherwise copied for public or private use, without permission from the publisher.

The game play, all graphic designs, this technical manual, its accompanying schematic diagrams, and the display manual are protected by the U.S. Copyright Act of 1976.

This Act provides for increased penalties for violating federal copyright laws. Courts *can impound* infringing articles while legal action is pending. If infringers are convicted, courts can *order destruction* of the infringing articles.

In addition, the Act provides for payment of statutory damages of up to \$250,000 in certain cases. Infringers may also have to pay costs and attorneys' fees and face an imprisonment of up to five years.

Atari Games Corporation will aggressively enforce its copyrights against any infringers. *We will use all legal means* to immediately halt any manufacture, distribution, or operation of a copy of video games made by us. Anyone who purchases such copies risks forfeiting such a game.

Published by:

Atari Games Corporation
675 Sycamore Drive
P.O. Box 361110
Milpitas, California 95035

Printed in the U.S.A. 11R

Notice Regarding Non-ATARI® Parts

▲ WARNING ▲

Use of non-ATARI parts or modifications of any ATARI game circuitry may adversely affect the safety of your game, and may cause injury to you and your players.

You may void the game warranty (printed on the inside back cover of this manual) if you do any of the following:

- Substitute non-ATARI parts in the game.
- Modify or alter any circuits in the game by using kits or parts *not* supplied by Atari Games Corporation.

NOTE

This equipment generates, uses, and can radiate radio frequency energy, and if not installed and used in accordance with the instruction manual, may cause interference to radio communications. It has been tested and found to comply with the limits for a Class A computing device pursuant to Subpart J of Part 15 of Federal Communications Commission (FCC) Rules, which are designed to provide reasonable protection against such interference when operated in a commercial environment. Operation of this equipment in a residential area or modification to this equipment is likely to cause interference, in which case the user, at his own expense, will be required to take whatever measures may be required to correct the interference. If you suspect interference from an ATARI® game at your location, check the following:

- All ground wires in the game are properly connected as shown in the game wiring diagram.
- The power cord is properly plugged into a grounded three-wire outlet.
- On games provided with an Electromagnetic Interference (EMI) ground plane, be sure the game printed-circuit boards (PCBs) are properly installed on the EMI Ground Plane. If you are still unable to solve the interference problem, please contact Customer Service at Atari Games Corporation. See the inside front cover of this manual for service in your area.

Table of Contents

1	Set-Up	
	How to Use This Manual	1-1
	Inspecting the Game	1-2
	Control and Switch Locations	1-2
	Setting the Coin and Game Option Settings	1-3
	Game Play	1-3
2	Self-Test	
	Self-Test Switches	2-2
	Service Switch	2-2
	Types of Self-Tests	2-2
	RAM/ROM Test	2-2
	Game Options Screen	2-2
	Switch Test	2-4
	Sound Test	2-5
	Crosshatch Test	2-5
	Color Test	2-6
	A.D.S. (Auto Data Sampling) Table Screen	2-6
3	Maintenance	
	Preventive Maintenance	3-2
	Preventive Maintenance Intervals	3-2
	Removing the Control Panel	3-2
	Cleaning the Push-Button Leaf Switches	3-2
	Cleaning the Coin Mechanism	3-2
	Cleaning the Interior Components	3-2
	Joystick Control	3-3
	Corrective Maintenance	3-3
	Removing the Game PCB	3-4
	Removing the Video Display	3-4
	Replacing the Video Display	3-5
	Removing the Speaker	3-6
4	Illustrated Parts Lists	
	See List of Illustrations that follows.	

List of Illustrations

Figure 1-1	Control and Switch Locations	1-2
Figure 2-1	Game Options Screen	2-3
Figure 2-2	Switch Test Screen	2-4
Figure 2-3	Sound Test Screen	2-5
Figure 2-4	Crosshatch Test Screen	2-6
Figure 2-5	Color Test Screen	2-6
Figure 2-6	A.D.S. Table Screen	2-6
Figure 3-1	Leaf Switch and Joystick Removal	3-3
Figure 3-2	Joystick Lubrication	3-4
Figure 3-3	Control Panel, Video Display, and Speaker Removal	3-5
Figure 4-1	Cabinet-Mounted Assemblies	4-2
Figure 4-2	Control Panel Assembly	4-5
Figure 4-3	Joystick Assembly	4-6
Figure 4-4	Switching/Linear (SL) Power Supply Assembly	4-8
Figure 4-5	Coin Acceptors, Inc. Coin Door Assembly	4-12
Figure 4-6A	Pac-Mania CPU PCB Assembly	4-16
Figure 4-6B	Pac-Mania ROM PCB Assembly	4-19
Figure 4-7	Pac-Mania End PCB Assembly	4-23

List of Tables

Table 1-1	Game Specifications	1-3
Table 2-1	RAM/ROM Error Messages	2-2
Table 2-2	Game Option Settings	2-3
Table 2-3	Special Settings on DIP Switch	2-7
Table 3-1	Recommended Preventive Maintenance Intervals	3-2

Safety Summary

The following safety precautions apply to all game operators and service personnel. Specific warnings and cautions will be found throughout this manual where they apply.

▲ WARNING ▲

Properly Ground the Game. Players may receive an electrical shock if this game is not properly grounded! To avoid electrical shock, do not plug in the game until it has been inspected and properly grounded. This game should only be plugged into a grounded three-wire outlet. If you have only a 2-wire outlet, we recommend you hire a licensed electrician to install a grounded outlet. Players may receive an electrical shock if the control panel is not properly grounded! After servicing any parts on the control panel, check that the grounding wire is firmly secured to the inside of the control panel. Only then should you lock up the game.

AC Power Connection. Before connecting the game to the AC power source, verify that the game's power supply is properly configured for the line voltage in your location.

Disconnect Power During Repairs. To avoid electrical shock, disconnect the game from the AC power source before removing or repairing any part of the game. When removing or repairing the video display, extra precautions must be taken to avoid electrical shock because high voltages may exist within the display circuitry and cathode-ray tube (CRT) even after power has been disconnected. Do not touch internal parts of the display with your hands or with metal objects! Always discharge the high voltage from the CRT before servicing this area of the game. To discharge the CRT: Attach one end of a large, well-insulated, 18-gauge jumper wire to ground. Momentarily touch the free end of the grounded jumper to the CRT anode by sliding it under the anode cap. Wait two minutes and discharge the anode again.

Use Only ATARI Parts. To maintain the safety integrity of your ATARI game, do not use non-ATARI parts when repairing the game. Use of non-ATARI parts or other modifications to the game circuitry may adversely affect the safety of your game, and injure you or your players.

Handle the CRT With Care. If you drop the CRT and it breaks, it may implode! Shattered glass can fly six feet or more from the implosion.

Use the Proper Fuses. To avoid electrical shock, use replacement fuses which are specified in the parts list for this game. Replacement fuses must match those replaced in fuse type, voltage rating, and current rating. In addition, the fuse cover must be in place during game operation.

CAUTION

Properly Attach All Connectors. Make sure that the connectors on each printed-circuit board (PCB) are properly plugged in. Note that they are keyed to fit only one way. If they do not slip on easily, do not force them. A reversed connector may damage your game and void the warranty.

Ensure the Proper AC Line Frequency. Video games manufactured for operation on 60 Hz line power (i.e., United States) must not be operated in countries with 50 Hz line power (i.e., Europe). The fluorescent light ballast transformer will overheat, causing a potential fire hazard if 60 Hz games are operated on power lines using 50 Hz. Check the product identification label of your game for the line frequency required.

ABOUT NOTES, CAUTIONS, AND WARNINGS

In all Atari publications, notes, cautions, and warnings have the following meaning:

NOTE—A highlighted piece of information.

CAUTION—Equipment and/or parts can be damaged or destroyed if instructions are not followed. You will void the warranty on Atari printed-circuit boards, parts thereon, and video displays if equipment or parts are damaged or destroyed due to failure of following instructions.

WARNING—Players and/or technicians can be injured or killed if instructions are not followed. (The word *WARNING* is always surrounded by international warning symbols—triangles with exclamation marks inside of them.)

Set-Up

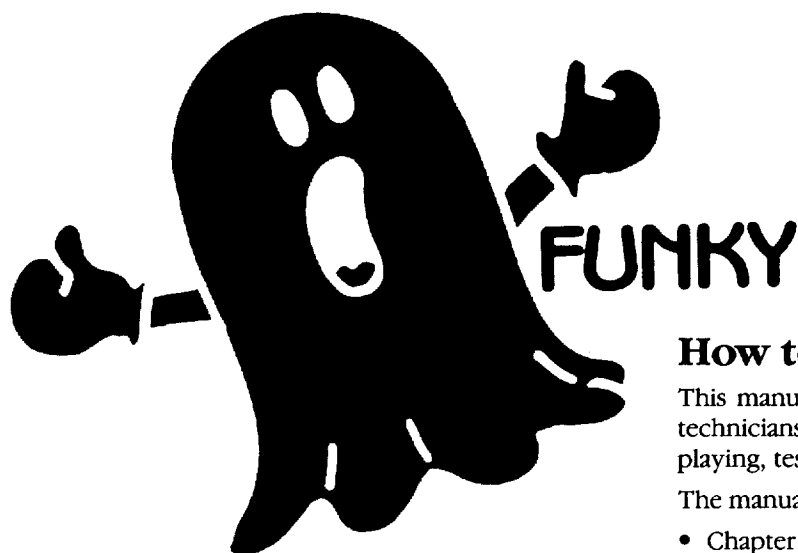

How to Use This Manual

This manual is written for game operators and service technicians, and provides information for setting up, playing, testing, and maintaining your Pac-Mania* game.

The manual is divided into the following chapters:

- Chapter 1 contains set-up and game play information.
- Chapter 2 contains self-test procedures.
- Chapter 3 contains preventive and corrective maintenance procedures.
- Chapter 4 contains illustrated parts lists.

Schematic diagrams for the Pac-Mania game circuitry are contained in the *Schematic Package Supplement* (SP-315) included with your game.

This chapter includes information required to set up and play your Pac-Mania game. Carefully read this information before applying power to the game.

▲ WARNING ▲

To avoid electrical shock, do not plug in the cabinet until it has been properly inspected and set up for the line voltage in your area.

This cabinet should only be connected to a grounded three-wire outlet. If you have only a two-wire outlet, we recommend you hire a licensed electrician to install a grounded outlet. Players can receive an electrical shock if the game is not properly grounded.

Do not touch internal parts of the display with your hands or with metal objects.



*Pac-Mania is engineered and designed by Namco Ltd. Manufactured by Atari Games. Trademark and © Namco 1987.

Inspecting the Game

CAUTION

Do not plug in the game until you have completed the following inspection steps.

Please inspect your Pac-Mania game carefully to ensure that the game is complete and delivered to you in good condition. Figure 4-1 shows the locations of the component parts of the game. Table 1-1 lists space, power, and environmental requirements.

1. Examine the exterior of the cabinet and the control panel for dents, chips, or broken parts.
2. Unlock and open both coin doors. Inspect the interior of the cabinet as follows:
 - a. Ensure that all plug-in connectors (on the cabinet harnesses) are firmly plugged in. Do not force connectors together. The connectors are keyed so they only fit in the proper orientation.

- b. Ensure that all plug-in integrated circuits on each PCB are firmly plugged into their sockets.
- c. Inspect the power cord for any cuts or dents in the insulation.
- d. Inspect the power supply. Make sure that the correct fuses are installed. Check that the harness is plugged in correctly and that the fuse-block cover is mounted in place. Check that the green ground wire is connected.
- e. Inspect other major subassemblies, such as the video display, printed-circuit boards (PCBs), control, and speaker. Make sure that they are mounted securely and that the green ground wires are connected.
- f. Make sure that the game power source and operating environment is within the limits specified in Table 1-1, Game Specifications.

Control and Switch Locations

The following control and switch descriptions are for the Pac-Mania game. Refer to Figure 1-1 for the locations of the controls and switches.

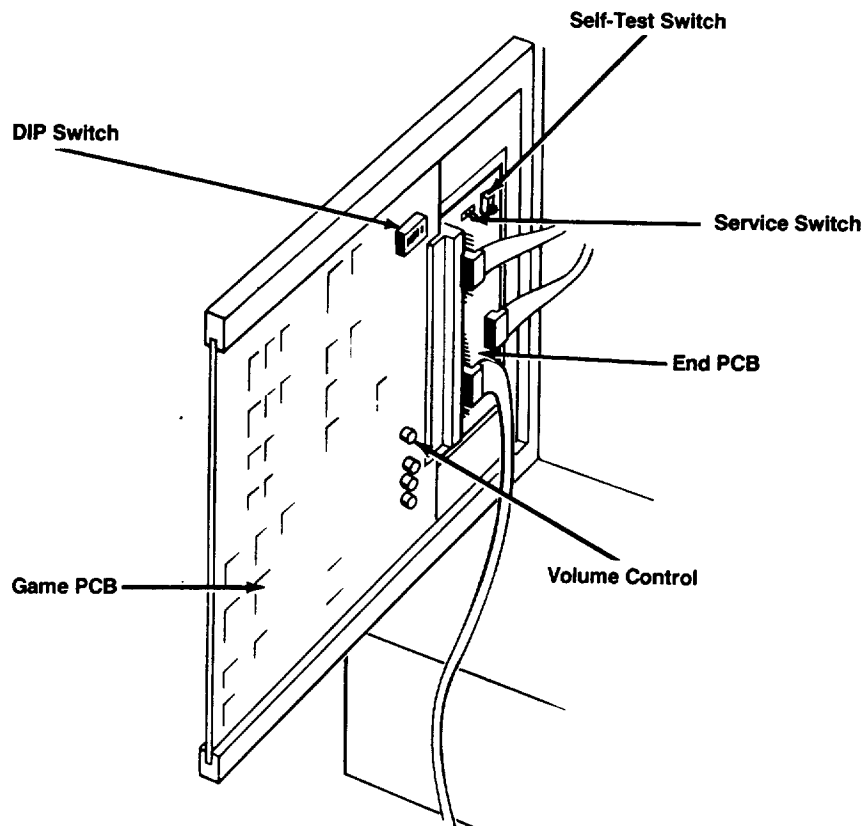

Figure 1-1 Control and Switch Locations

Table 1-1 Game Specifications

Characteristic	Specification
Power Consumption	164 V-A, 118 W RMS maximum
Temperature	+ 5° to + 38° C (+ 37° to + 100° F)
Humidity	Not to exceed 95% relative
Line Voltage	102 to 132 VAC (U.S. games)
Width	23 ¹ / ₁₆ in. (61 cm)
Depth	32 ¹ / ₈ in. (81 cm)
Height	70 ³ / ₁₆ in. (178 cm)
Weight	265 lbs. (120 kg)

Power On/Off Switch

The power on/off switch is located at the bottom rear of the cabinet. (See Figure 4-1.)

Volume Control

The volume control is located in the lower right corner of the Game PCB. The PCB is attached to the lower right side of the cabinet. The volume control adjusts the level of sound produced by the game.

Coin Counter

The coin counter is located on the shelf behind the upper coin door. The coin counter records the number of coins deposited.

Self-Test Switch

The game can be put in the Self-Test Mode to check game operation by turning on one of the two existing self-test switches. One self-test switch is located on the End PCB, connected to the front of the Game PCB. Both PCBs are attached to the lower right side of the cabinet.

A second self-test switch (switch 1) is located on the dual-inline-package (DIP) switch in the upper right corner of the Game PCB. Turning on switch 1 also selects the Self-Test Mode. (With the PCB installed in the cabinet, slide the button down for *on*.) Refer to Chapter 2 for a complete description of self-test operation.

Service Switch

The push-button service switch is located next to the self-test switch on the End PCB. The End PCB is connected to the front of the Game PCB, and both PCBs are attached to the lower right side of the cabinet. This switch has three functions, depending on whether the game is in the Self-Test Mode:

1. The switch is used as a coin switch when the game is not in the Self-Test Mode. Pressing the push-button gives the game one credit.

2. In the Self-Test Mode, press the push-button to advance to the next test screen.
3. To reach the A.D.S. (Auto Data Sampling) main menu, press the push-button service switch while turning off the self-test switch.

Setting the Coin and Game Option Settings

The Pac-Mania coin and game options are set in the Self-Test Mode. Refer to Chapter 2 for the recommended settings and the procedure for setting the options.

Game Play

This section of the manual describes the theme of the Pac-Mania game and the game play features.

Introduction

Pac-Mania is a one- or two-player (alternating) game in which players maneuver the new Pac-Man through a world of 3-D mazes. He's back in action . . . but with a new twist, BOUNCE power! Ready for a new generation of Pac-Man players, he can't wait for the chance to show off his new aerial maneuvers to the crowd! The "boss" ghost Clyde has recruited the talents of two new ghosts, Sue and Funky. Pac-Man must use his speed and cunning to outwit these annoying pests.

Pac-Man now faces new challenges as he enters the worlds of Block Town, Pac-Man's Park, Sandbox Land, and Jungly Steps. Fortunately for Pac-Man, he has the help of two "special items"—a green and red power pill. The green pill adds temporary speed, and the red awards double points. It's a whole new ball game for Pac-Maniacs!

Game Play

Game play begins with the opportunity for players to level select among one of three playfield worlds: Block Town, Pac-Man's Park or Sandbox Land. With Block Town being the easiest and Sandbox Land being the harder, players are accordingly rewarded for selecting and completing the challenges in this mode.

The player's main objective is to eat all dots and power pills in the mazes while avoiding persistent ghosts. Using the new BOUNCE button, players can bounce their way over the ghosts to avoid being caught. But two new ghosts have been added to insure that Pac-Man doesn't have it too easy. In fact, one of them can also bounce in the air like Pac-Man. Fortunately, these rivals of Pac-Man are only found in the more demanding worlds and mazes.

During play, the appearance of fruit and green/red power pills will trigger the bell. This alerts players immersed in the game who might otherwise miss these valuable items

the points range from 1,000 to 10,000. A green power pill awards extra speed; it is good until a yellow or red power pill is eaten and expires or a game life is lost. Red power pills award double points, and continue to do so until a game life is lost.

An optional continue feature is offered to allow players to continue their progress without having to start back at the beginning. It's a great way for Pac-Maniacs to learn and

practice strategies without having to re-start games from the beginning.

Bonus thresholds are offered at various score values, and are easily adjustable. Four difficulty settings are offered for maximum income. A unique A.D.S. (Auto Data Sampling) bookkeeping system is included to monitor length of play time, where game lives are lost, and where individual games end. The A.D.S. system is described in detail in Chapter 2 of this manual.

Self-Test

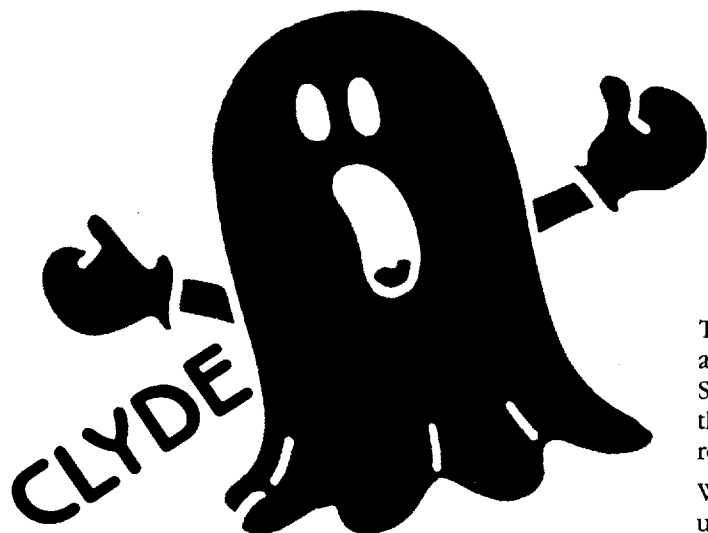

The Pac-Mania* game tests itself and provides visual and audible indications of the condition of the game circuitry. Self-test information is displayed on the screen and through the sound system. No additional equipment is required.

We suggest that you perform a self-test when you first set up the game, each time you collect the money, or when you suspect game failure. Coin and game options are selected in the Self-Test Mode.

Five self-test screens provide information pertaining to the game circuits. The tests are arranged in the sequence in which they occur after the self-test switch is turned on.

When the self-test switch is turned on, and then the game power is turned on, the game enters the full Self-Test Mode. During this full self-test, a complete RAM/ROM test is performed before displaying the Game Options screen. If the self-test switch is turned on when the game is in the Attract Mode, the game enters a shorter Self-Test Mode. Turning the self-test switch off at any time during the Self-Test Mode causes the game to return to the Attract Mode.



*Pac-Mania is engineered and designed by Namco Ltd. Manufactured by Atari Games. Trademark and © Namco 1987.

Self-Test Switches

The game can be put in the Self-Test Mode to check game operation by turning on one of two existing self-test switches. One self-test switch is located on the End PCB, connected to the front of the Game PCB. Both PCBs are attached to the lower right side of the cabinet. (See Figure 1-1.)

A second self-test switch (switch 1) is located on the dual-inline-package (DIP) switch in the upper right corner of the Game PCB. Turning on switch 1 also selects the Self-Test Mode. (With the PCB installed in the cabinet, slide the button down for *on*.)

Service Switch

The push-button service switch is located next to the self-test switch on the End PCB. The End PCB is connected to the front of the Game PCB, and both PCBs are attached to the lower right side of the cabinet. This switch has two functions, depending on whether the game is in the Self-Test Mode:

1. The switch is used as a coin switch when the game is not in the Self-Test Mode. Pressing the push-button gives the game one credit.
2. In the Self-Test Mode, press the push-button to advance to the next test screen.
3. To reach the A.D.S. main menu, press the push-button service switch while turning off the self-test switch.

Types of Self-Tests

The Pac-Mania self-test consists of the following screens: Game Options, Switch Test, Sound Test, Crosshatch Test, and Color Test.

NOTE

For all subsequent tests in the self-test, the following summarizes the functions of the joystick control and switches:

- The joystick up/down movement selects different choices.
- The joystick left/right movement changes that item's setting.
- The push-button service switch sequences the game to the next self-test screen.
- The Bounce button starts the selected sound in the Sound Test.

RAM/ROM Test

When the self-test switch is turned on, and then the game power is turned on, the game enters the full Self-Test Mode. During this mode a complete RAM/ROM test is performed.

The RAM Test indicates the condition of the game RAM and the custom integrated circuits (ICs). The ROM Test

indicates the condition of the game's ROM circuitry. If these tests pass, no screen message is displayed, and the game proceeds directly to the Game Options Screen.

If the RAM or any of the custom ICs fail, the message *RAM x ERROR* or *I/O ERROR 64* is displayed. If any of the ROMs fail, the screen displays the message *ROM x ERROR* (see Table 2-1 for all RAM/ROM error messages).

Game Options Screen

The Game Options screen is shown in Figure 2-1. This screen indicates the current settings of the coin and game options, and is also used to change these settings. Table 2-2 lists the available options and the default (recommended) settings.

Table 2-1 RAM/ROM Error Messages

NOTE

ROM PCB is the larger circuit board.
CPU PCB is the smaller circuit board.

Error Message	Possible Bad Integrated Circuit
ROM 0 ERROR	ROM at location H10 on the ROM PCB
ROM 1 ERROR	ROM at location K10 on the ROM PCB
ROM 2 ERROR	ROM at location L10 on the ROM PCB
ROM 3 ERROR	ROM at location M10 on the ROM PCB
ROM 4 ERROR	ROM at location N10 on the ROM PCB
ROM 5 ERROR	ROM at location P10 on the ROM PCB
ROM 6 ERROR	ROM at location S10 on the ROM PCB
ROM 7 ERROR	ROM at location T10 on the ROM PCB
RAM 1 ERROR*	RAM at location B2, D2, or E2 on the CPU PCB
RAM 2 ERROR	RAM at location D6 or E6 on the CPU PCB
RAM 3 ERROR	RAM at location S5 on the CPU PCB
RAM 4 ERROR	RAM at location H1 on the CPU PCB
RAM 5 ERROR	RAM at location L5 on the CPU PCB
RAM 6 ERROR*	RAM at location B2, D2, or E2 on the CPU PCB
RAM 7 ERROR	RAM at location D6, or E6 on the CPU PCB
I/O ERROR 64**	RAM at location H1 on the CPU PCB, or the I/O Processor at location M4 on the ROM PCB

*Either of these error messages may be accompanied by a four-digit number. Look at the first of the four lines and ignore the bottom three lines. Also ignore the fact that the entire screen may be upside down. This four-digit number may indicate one specific integrated circuit is bad, as follows:

If the number is between 0002 and 0802, this indicates location B2.
If ABCD is between 0804 and 1002, this indicates location D2.
If ABCD is between 1004 and 1802, this indicates location E2.

**If this error message is accompanied by a four-digit number, look at its left two digits. If those digits are 02, this indicates the RAM at location H1 is bad. If those digits are not 02, this indicates the I/O Processor at location M4 is bad.

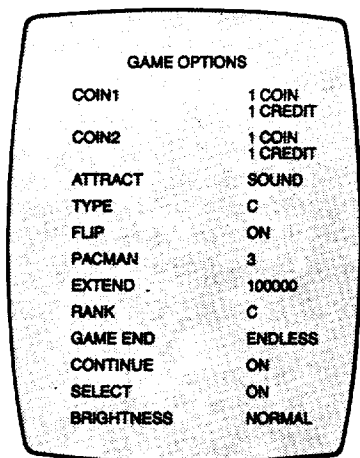

Figure 2-1 Game Options Screen

Coin and Credit Options

The current coin and credit option settings are displayed on the screen as:

```
COIN1  1 COIN
        1 CREDIT

COIN2  1 COIN
        1 CREDIT
```

These are the default (recommended) settings for coin mechanisms 1 (left) and 2 (right). The available coin and credit options are as follows:

Coin 1: 1 to 9 Coin(s) for 1 to 9 Credit(s)
 Coin 2: 1 to 9 Coin(s) for 1 to 9 Credit(s)

The coin and credit options can be changed by moving the joystick left/right.

Attract Mode Music Setting

The Attract Mode Music setting indicates that music is selected when the game is in the attract mode. This setting is displayed on the screen as:

```
ATTRACT  SOUND
```

The default (recommended) setting has the sound on. The sound can be turned off by moving the joystick left/right.

Table 2-2 Game Option Settings

Option Name	Available Settings
Coins to start (Coin Mech 1 or left one)	1 ◀, 2, 3, 4, 5, 6, 7, 8, 9 Coin(s) for 1 ◀, 2, 3, 4, 5, 6, 7, 8, 9 Credit(s)
Coins to start (Coin Mech 2 or right one)	1 ◀, 2, 3, 4, 5, 6, 7, 8, 9 Coin(s) for 1 ◀, 2, 3, 4, 5, 6, 7, 8, 9 Credit(s)
Music in attract mode	Sound on ◀ Sound off
Cabinet type	A B C ◀
Video display orientation ("flip")	On ◀ Off
Starting lives ("Pac-Man") per game	1 2 3 ◀ 4 5
Extended play granted at . . .	50,000 points 100,000 points ◀ 150,000 points No extended play
Game difficulty ("rank")	A (Easy) B (Standard) C (Hard) ◀ D (Very Hard)
Game end	7 rounds 19 rounds Endless game ◀
Game continuation with add-a-coin	On ◀ Off
Level select	On ◀ Off
Monitor brightness	Normal ◀ High

◀ *Manufacturer's recommended settings*

Cabinet Type Setting

The Cabinet Type setting indicates that the cabinet is the normal, upright type with one set of player controls. This setting is displayed on the screen as:

```
TYPE  C
```

Do not change this default (recommended) setting.

Video Display Orientation Setting

The Video Display Orientation setting is displayed on the screen as:

```
FLIP  ON
```

Do not change this default (recommended) setting.

Starting Lives Setting

The Starting Lives setting indicates the number of lives granted when game play begins, and is displayed on the screen as:

PACMAN 3

3 lives is the default (recommended) setting. The setting can be changed to 1–5 lives by moving the joystick left/right.

Extended Play Setting

The Extended Play setting indicates at what point score an extra life is granted, and is displayed on the screen as:

EXTEND 10000

100,000 points is the default (recommended) setting. The setting can be changed to 50,000, 100,000, 150,000 points or nothing (no extended play) by moving the joystick left/right.

Game Difficulty Setting

The Game Difficulty setting indicates the difficulty level of the game, and is displayed on the screen as:

RANK C

C (hard) is the default (recommended) setting. The setting can be changed to A (easy), B (standard), or D (very hard) by moving the joystick left/right.

Final Round Setting

The Final Round setting indicates how long players can play before the game will automatically end. This setting is displayed on the screen as:

GAME END ENDLESS

An endless game (provided the player makes no mistakes) is the default setting. The setting can be changed to 7 rounds or 19 rounds by moving the joystick left/right.

Game Continuation Setting

The Game Continuation setting indicates game continuation with the add-a-coin feature. This setting is displayed on the screen as:

CONTINUE ON

On is the default (recommended) setting. The setting can be changed to Off by moving the joystick left/right.

Level Select Setting

The Level Select setting indicates whether this function is turned on. If turned on, it lets players choose from among

three points at which they may begin the game—round 1, 2, or 4. This setting is displayed on the screen as:

SELECT ON

On is the default (recommended) setting. The setting can be changed to off by moving the joystick left/right.

Brightness

The Brightness setting adjusts the brightness of various types of displays. This setting is displayed on the screen as:

BRIGHTNESS NORMAL

Do not change this default (recommended) setting.

Switch Test

The Switch Test screen is shown in Figure 2-2. This test indicates the current DIP switch settings, and tests the self-test switch, start switches, coin mechanisms, player control, and buttons.

NOTE

When the switch/control is displayed in red, the switch/control is on. White indicates that the switch/control is off.

DIP Switch Settings

The Pac-Mania game has one DIP option switch at location 3A on the Game PCB. (See Figure 1-1.) The DIP Switch settings indicate the current settings of the DIP Switch, and are displayed on the screen as:

DIPSW 12345678

The row of numbers refers to switches 1 through 8 on Switch A. When the switch number is displayed in red,

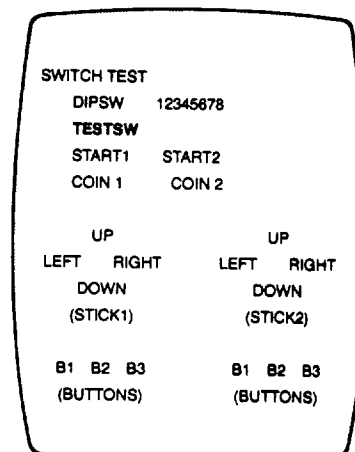

Figure 2-2 Switch Test Screen

the switch is on. When the number is white, the switch is off.

NOTE

Switches 1-4 and 6-8 should be turned off for game play. Switch 1 should be turned on only when using it as the self-test switch to enter the Self-Test Mode. Switch 5 should be turned on to allow the A.D.S. bookkeeping system to record player data.

To change the settings, use a pen or a sharp-pointed instrument to slide the appropriate small buttons to different settings. With the Game PCB installed in the cabinet, slide the button down for *on* and up for *off*.

Self-Test Switch

The Self-Test Switch setting indicates the condition of the self-test switch and is displayed on the screen as:

TESTSW (This switch is always on in the Self-Test Mode.)

Start Switch

The Start Switch setting indicates the condition of the two black-cap LED Start switches, and is displayed on the screen as:

START1 *START2*

Coin Mechanisms

The Coin Mechanisms setting indicates the condition of the left and right coin mechanisms and is displayed on the screen as:

COIN1 *COIN2*

COIN1 refers to the left mechanism and *COIN2* the right mechanism.

Joystick

The Joystick setting indicates the condition of the joystick and is displayed on the screen as:

UP
LEFT RIGHT
DOWN
(*STICK1*)

Moving the joystick up/down or left/right displays that position in red. *STICK2* or joystick 2 is not used in Pac-Mania.

Buttons

The Buttons setting indicates the condition of the buttons and is displayed on the screen as:

B1 B2 B3
(*BUTTONS*)

B1 is the red Bounce button. B2 and B3 are not used in Pac-Mania.

Sound Test

The Sound Test screen is shown in Figure 2-3. This screen indicates the condition of the sound-effects circuitry (when sound is selected in the Attract Mode setting). This test is displayed on the screen as:

VOICE NUMBER 000

PSG NUMBER 00

FM NUMBER 00

AUDIO

3D TEST

VOICE NUMBER indicates the one voice phrase in the game. *PSG NUMBER* indicates sound effect, and *FM NUMBER* indicates music. *AUDIO* tests the channels. (In Pac-Mania one speaker is used for both channels.) The 3D Test is not used.

Moving the joystick up/down or left/right selects the different item number. Pressing the Bounce button starts the selected sound.

Crosshatch Test

The Crosshatch screen is shown in Figure 2-4. This screen indicates the condition of the video display size, linearity, and convergence, and is used to adjust all three.

The grid pattern should be white. Check this pattern for the following characteristics:

- The four corners of the frame around the grid pattern should touch all four corners of the screen.

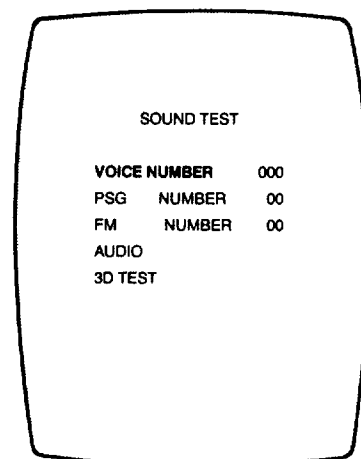

Figure 2-3 Sound Test Screen

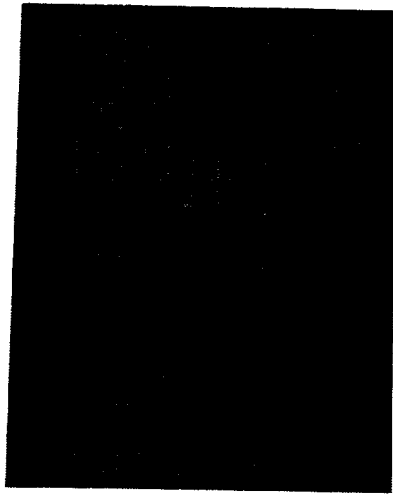

Figure 2-4 Crosshatch Test Screen

- The grid lines should exhibit no pincushioning or barreling.

Refer to the display manual included with your game for more detailed adjustment procedures or to determine possible cause of failure.

Color Test

The Color Test screen is shown in Figure 2-5. This screen indicates the condition of the video display color circuits, and is used to adjust the color and brightness.

There should be four vertical bars of white, blue, green, and red. The bars should be brightest at the top of the screen, and darkest (black) at the bottom. The middle of the bars should be dim.

If the display characteristics are not correct, refer to the display manual included with your game for the color-gun adjustment procedure, or to determine the possible cause of failure.

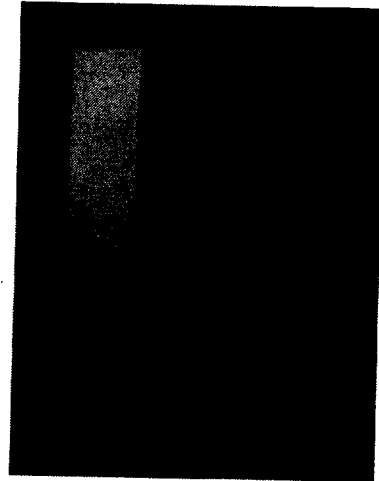

Figure 2-5 Color Test Screen

A.D.S. Table Screen

The A.D.S. (Auto Data Sampling) main menu is shown in Figure 2-6. To reach this screen, press and hold down the push-button service switch, then turn *off* the Self-Test switch. The A.D.S. bookkeeping function will gather player data only if toggle 5 of the DIP switch on the ROM PCB is turned on; *be sure it is on if you want to collect player data*. Refer to Table 2-3 for details about the special option settings available on this DIP switch.

On the A.D.S. Table main menu, you can select from three different screens. Move the joystick up or down until the desired screen name turns red; then press the BOUNCE button to view that screen. The three screens are as follows:

- **PLAY TIME RECORD:** Shows the number of games that were ended during each 30-second time span, from games of 30 seconds and under, to games 19½ minutes or longer in length.

- **MISS ROUND RECORD:** Shows the number of Pac-Man lives lost during each of the 24 available rounds.
- **OVER ROUND RECORD:** Shows the number of games ended during each of the 24 available rounds.

To zero out or reset the data in all three screens, on the main menu select the **DATA RESET ALL** phrase and press the BOUNCE button. To exit from the A.D.S. mode, select the **EXIT A.D.S. MODE** phrase, and press the BOUNCE button.

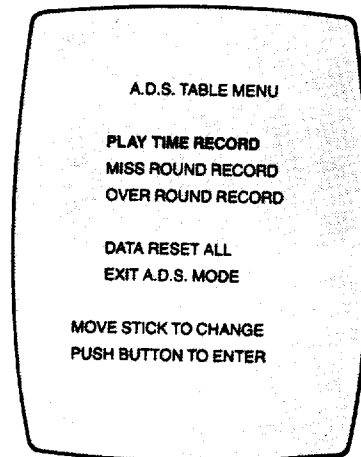

Figure 2-6 A.D.S. Table Screen

Table 2-3 Special Settings on DIP Switch

Settings of 8-Toggle Switch on Pac-Mania ROM PCB (at A3)								Option
1	2	3	4	5	6	7	8	
Off								Self-Test Mode
On								Normal play ◀
								Enter Self-Test mode
	Off							Freeze Display
	On							Normal (moving) display ◀
								Frozen display
								A.D.S. (Auto Data Sampling)
				Off				No bookkeeping
				On				A.D.S. bookkeeping is done ◀

◀ *Manufacturer's recommended settings*

N O T E S

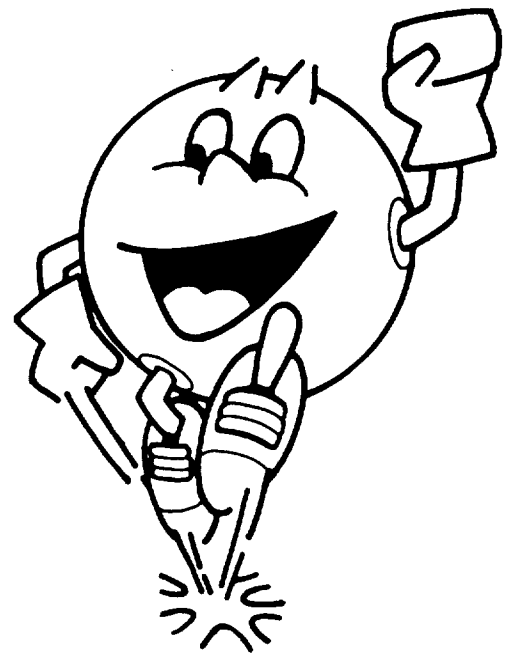

Maintenance



This chapter includes preventive and corrective maintenance procedures for the Pac-Mania game components that are subject to the most use. To assure maximum trouble-free operation from this game, we recommend that preventive maintenance be performed as described in this chapter.

Removal and replacement procedures are provided for components that might require corrective maintenance. Chapter 4, Illustrated Parts Lists, can also be used to locate the parts of this game that are mentioned, but not illustrated, in the maintenance procedures.



Preventive Maintenance

Preventive maintenance includes cleaning, lubricating, and tightening hardware. How often preventive maintenance is performed depends upon the game environment and frequency of play. However, for those components listed in Table 3-1 Preventive-Maintenance Intervals, we recommend that preventive maintenance be performed at the intervals specified.

Preventive-Maintenance Intervals

The preventive-maintenance intervals specified in Table 3-1 are the recommended minimum requirements for the components listed.



WARNING



To avoid possible electrical shock, turn off the game before performing any maintenance procedures.

Removing the Control Panel

Perform the following procedure to remove/replace the control panel. (See Figure 3-3.)

1. Unlock and open the upper coin door and the front access panel.
2. Carefully reach up through the upper coin door opening and access panel. Release the two spring draw latches located under the control panel on each side of the cabinet.
3. Grasp the control panel on the top edge (next to the display shield) and gently tilt the panel up slightly. Remove the panel from the front edge of the cabinet. Stand the control panel on its back edge by placing it in the wood slots located under the control panel on each side of the cabinet. The panel is now in position for servicing the leaf switches or the joystick control.
4. If you need to remove the control panel, disconnect the control harness connector from the main harness.
5. Carefully lift the control panel from the cabinet.
6. Replace the control panel in the reverse order of removal.

Table 3-1 Recommended Preventive-Maintenance Intervals

Joystick Control	Lubricate and tighten hardware at least every three months.
Coin Mechanism	Inspect whenever you collect coins. Clean at least every three months.

Cleaning the Push-Button Leaf Switches

Perform the following procedure to clean the push-button leaf switch contacts and tighten the securing hardware. (See Figure 3-1.)

1. Follow the procedure described in steps 1–3 above for removing the control panel.
2. Use electrical contact cleaner to clean the contacts. Do not burnish them. When the push button is pressed, the wiping action of the cross-bar contacts provides a self-cleaning feature.
3. Using a $\frac{1}{16}$ -inch open-end wrench, tighten the stamped nut securing the pushbutton leaf switch to the control panel.

Cleaning the Coin Mechanism

Use a soft-bristled brush to remove loose dust or foreign material from the coin mechanism. A toothbrush can be used to remove any stubborn build-up of residue in the coin path. After cleaning the coin mechanism, blow out all of the dust with compressed air.

Cleaning the Interior Components

Perform the following procedure to clean the components inside the cabinet.



WARNING



Turn off the game power, but do not unplug the power cord before cleaning inside the cabinet. The power cord provides a ground path for stray static voltages that might be present on the cleaning tools.

1. Unlock and remove the front access panel.
2. Use a vacuum cleaner with a soft long-bristled brush attachment or a soft-bristled paint brush to remove loose dirt and dust accumulated on the inside of the cabinet. Be sure to clean the electrical components thoroughly (power supplies, PCB assemblies, display, etc.).

CAUTION

Be extremely careful when cleaning the electrical components inside the cabinet. Avoid touching the electrical components with any solid object other than the soft bristles of the vacuum attachment or paint brush.

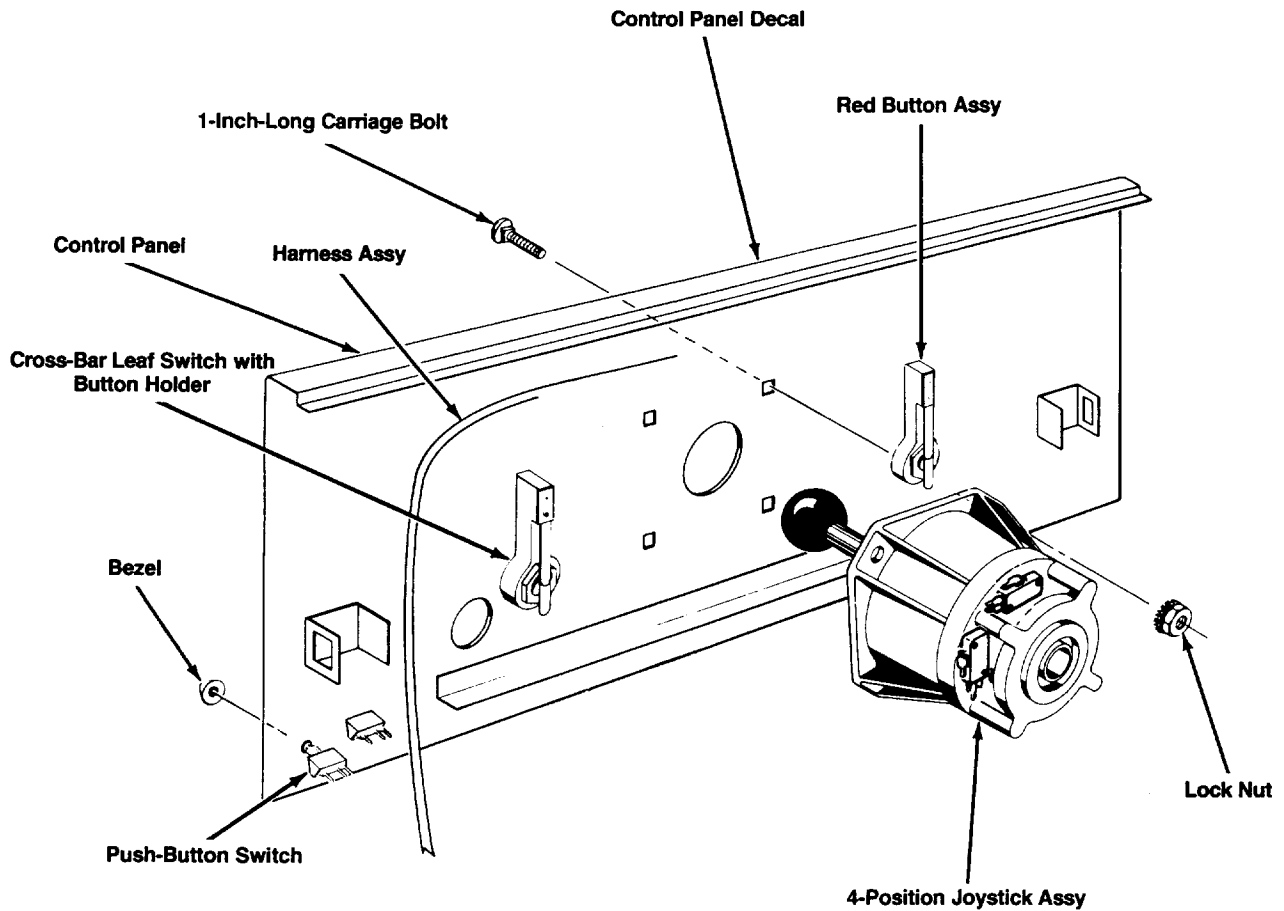

Figure 3-1 Leaf Switch and Joystick Removal

Joystick Control

Preventive maintenance on the joystick control consists of inspecting the pivot and actuator-balls for excessive wear or dirt, lubricating the pivot ball, replacing the microswitches, and, if necessary, replacing or tightening the securing hardware.

Lubricating the Joystick Control

Perform the following procedure to lubricate and tighten the joystick control. (See Figure 3-2.)

1. Remove the control panel as previously described.
2. Apply a light film of Lithium grease (Atari part no. 107027-001) to the lubrication points shown in Figure 3-2.
3. Using a $\frac{3}{8}$ -inch wrench, tighten the four nuts holding the joystick to the control panel.
4. Using a Phillips screwdriver, tighten the four screws holding the positioning plate to the lower housing.

Corrective Maintenance

Corrective maintenance consists of removing, disassembling, reassembling, and replacing the push-button leaf switches, joystick control, game printed-circuit board (PCB), video display, and speaker. The procedures for re-

moving and replacing the Game PCB, video display, and the speaker follow.

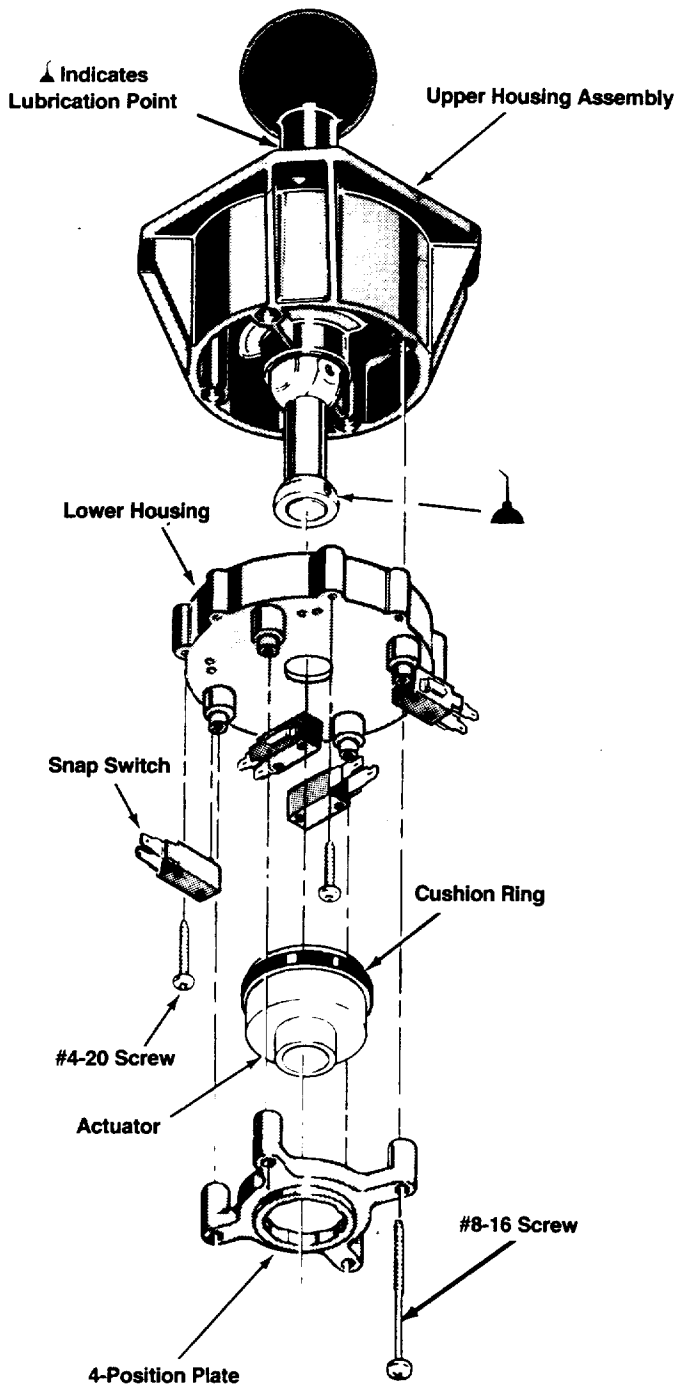

Figure 3-2 Joystick Lubrication

Removing the Game PCB

Perform the following procedure to remove/replace the Game PCB.

1. Turn the cabinet power off.

2. Unlock and remove the front access panel from the cabinet.
3. Disconnect the harness connectors from the End PCB.
4. Use a Phillips screwdriver to remove the three screws and washers holding the Game PCB and End PCB to the cabinet.
5. Grasp the front edge of the Game PCB and gently slide it forward out of the slotted guide.
6. Disconnect the End PCB from the Game PCB.
7. Replace the Game PCB in the reverse order of removal.

Removing the Video Display

Perform the following procedure to remove/replace the video display. (See Figure 3-3.)

1. Turn the game power off and wait two minutes. Unplug the power cord.
2. Remove the control panel as described under *Preventive Maintenance*.
3. Remove the video display shield.
4. Carefully remove the bezel from the foam tape holding it in place.
5. Use a Phillips screwdriver to remove the four screws holding the rear access panel to the cabinet.

⚠ WARNING ⚠ High Voltage

The video display contains lethal high voltages. To avoid injury, do not attempt to service this display until you observe all precautions necessary for working on high-voltage equipment.

X-Radiation

The video display has been designed to minimize X-radiation. However, to avoid possible exposure to soft X-radiation, **never** modify the high-voltage circuitry.

Implosion Hazard

The cathode-ray tube may implode if struck or dropped. Shattered glass may cause injury within a 6-foot radius. Use care when handling the display.

6. Discharge the high voltage from the cathode-ray tube (CRT) before proceeding. The display assembly contains a circuit for discharging the high voltage to ground when power is removed. However, to make certain, always discharge the display as follows.
 - a. Attach one end of a large, well-insulated, 18-gauge jumper wire to ground.
 - b. Momentarily touch the free end of the grounded jumper to the CRT anode by sliding it under the anode cap.

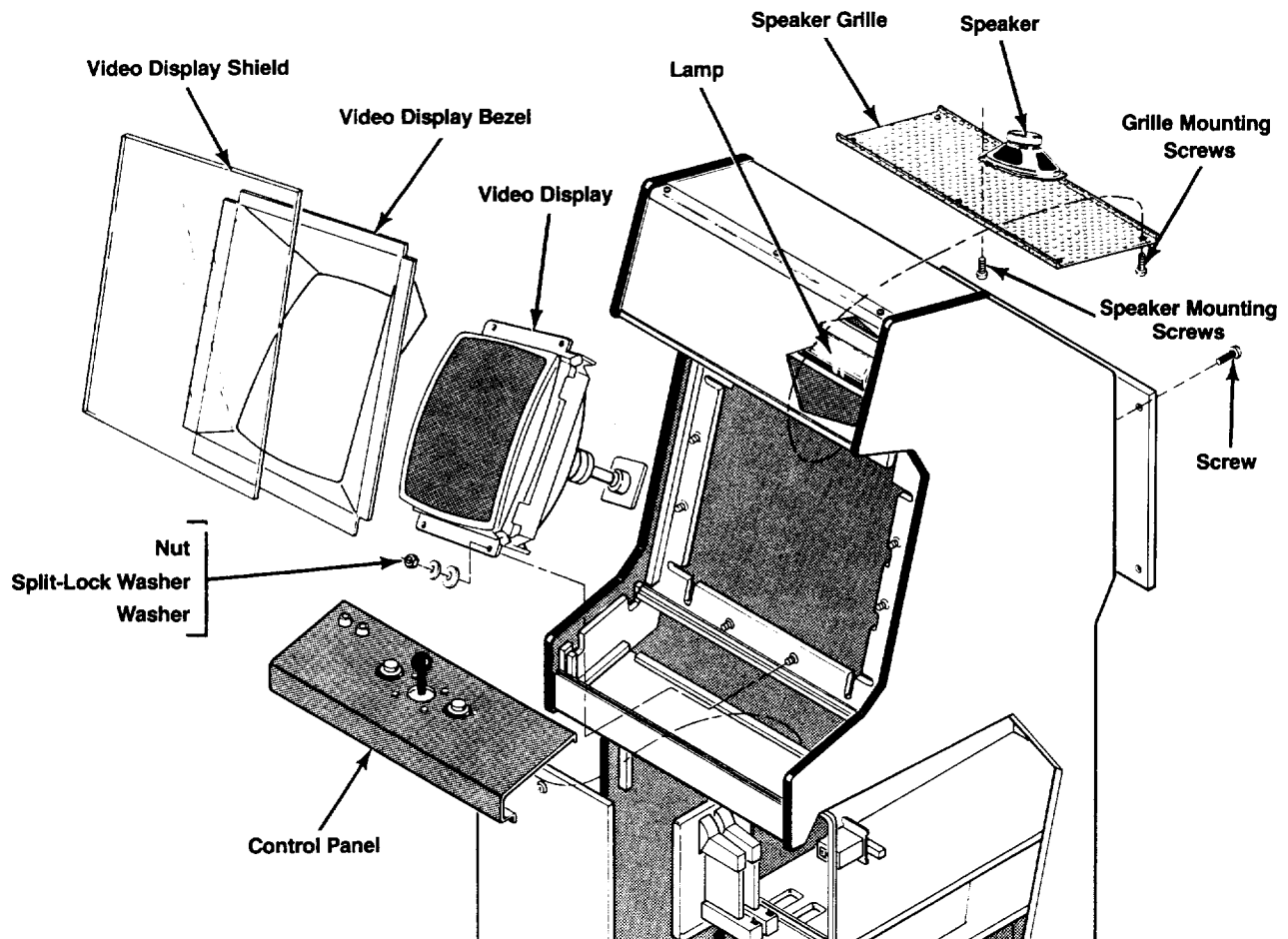

Figure 3-3 Control Panel, Video Display, and Speaker Removal

- c. Wait two minutes and repeat part b.
7. From the back of the cabinet, unplug the display harness connectors from the display.



WARNING



To avoid dropping the video display, use extreme care when removing the display from the cabinet. We recommend that no one weighing less than 150 pounds should attempt to remove the video display. In addition, we recommend that you wear gloves to protect your hands from the sheet-metal edges.

8. Use a $\frac{3}{8}$ -inch wrench to remove the four nuts and washers holding the video display to the cabinet shelf.
9. Carefully slide the display out through the front of the cabinet.
10. Replace the video display as described in the following procedure.

NOTE

Whenever the cathode-ray tube and yoke are replaced as a single unit, readjust the brightness, size, and centering as described in the display manual. Check the purity and convergence also according to the display manual instructions, but adjust both *only if required*.

Replacing the Video Display

Perform the following procedure to replace the video display in the cabinet. (See Figure 3-3.)

1. Gently lift the video display through the front of the cabinet.
2. Position the display so that the four slots in the chassis are aligned with the corresponding mounting holes in the cabinet shelf.
3. Tighten the four mounting nuts and washers using a $\frac{3}{8}$ -inch wrench.

4. Connect the display harness to the display PCB.
5. Replace the bezel.
6. Replace the video display shield.

Removing the Speaker

Perform the following procedure to remove/replace the speaker. (See Figure 3-3.)

1. Use a $\frac{1}{8}$ -inch square drive bit to remove the five screws holding the speaker grille to the cabinet. Remove the grille.
2. Use a Phillips screwdriver to remove the four screws holding the speaker to the cabinet.
3. Remove the speaker just far enough to disconnect the two speaker wires.
4. With the tabs pointed outward, replace the speaker in the reverse order of removal.

CAUTION

Do not touch the speaker cone when handling the speaker. The cone material is fragile and can be easily damaged.

Illustrated Parts Lists

This chapter provides information you need to order parts for your game. Common hardware (screws, nuts, washers, etc.) has been deleted from most of the parts lists.

The PCB parts lists are arranged in alphabetical order by component. Each component subsection is arranged alphanumerically by reference designator.

Other parts lists are arranged alphanumerically by Atari part number. In these parts lists, all A-prefix numbers come first. Following these are numbers in sequence evaluated up to the hyphen, namely 00- through 99-, then 000598- through approximately 201000-.

When ordering parts, please give the part number, part name, number of this manual, and serial number of your game. This will help us fill your order rapidly and correctly. We hope the results will be less downtime and more profit from your game.

Atari Customer Service numbers are listed on the inside front cover of this manual.



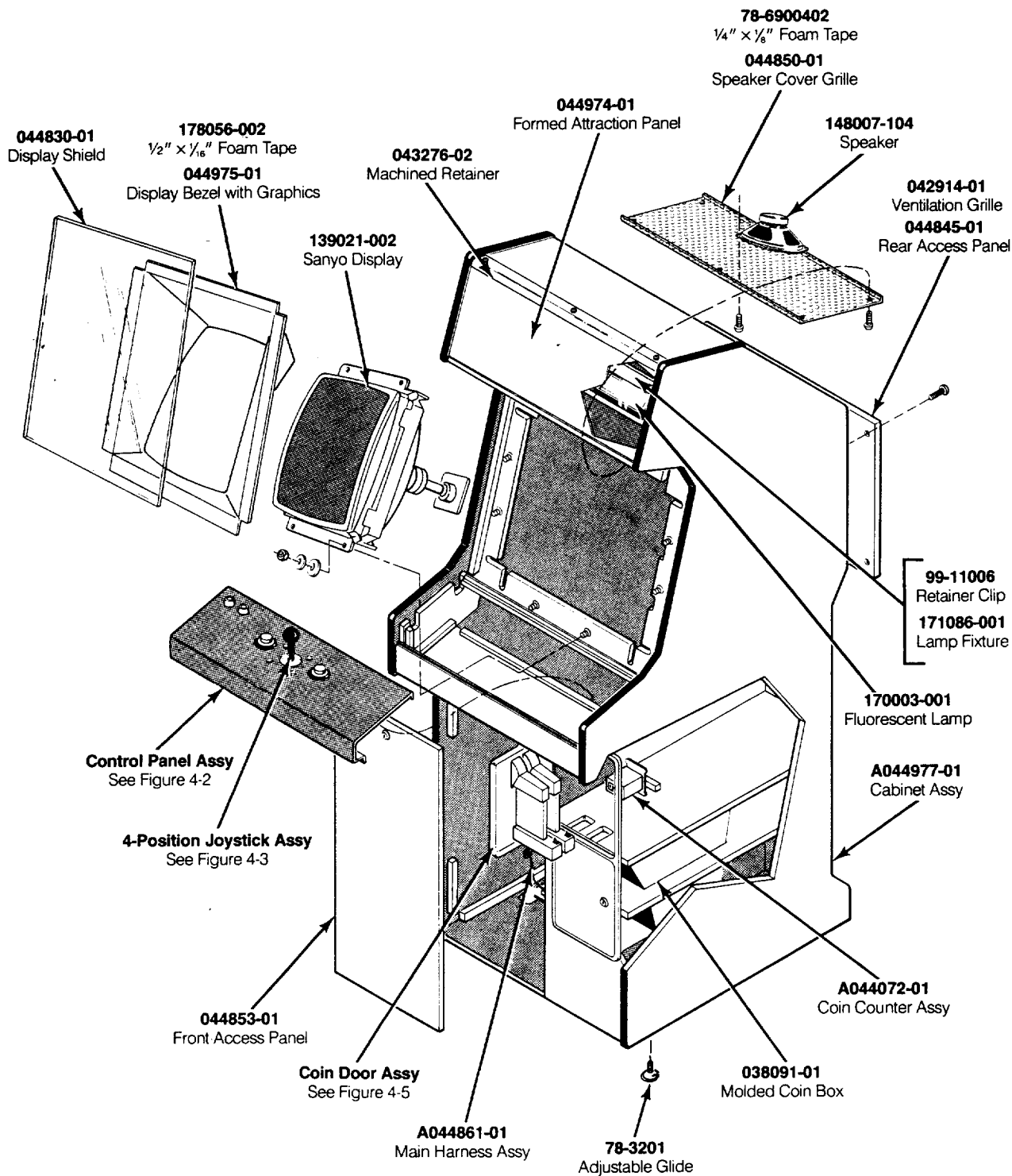

**Figure 4-1 Cabinet-Mounted Assemblies
A044970-01 A**

NOTE

To comply with emission requirements, the Federal Communications Commission requires that the ground strap be secured to the PCB ground plate. *Do not operate this game without properly installing the ground strap.*

Items Not Shown:

- A044862-01**
AC Harness Assy
- 034536-02**
Vibration Damper
- A044864-01**
Video Harness Assy
- A044865-01**
+5V Harness Assy
- A044866-01**
Ground Strap Assy
- A044866-02**
Ground Strap Assy
- 044831-01**
Ground Plate
- 178013-001**
Spring Draw Latch
- End PCB Assy**
See Figure 4-7

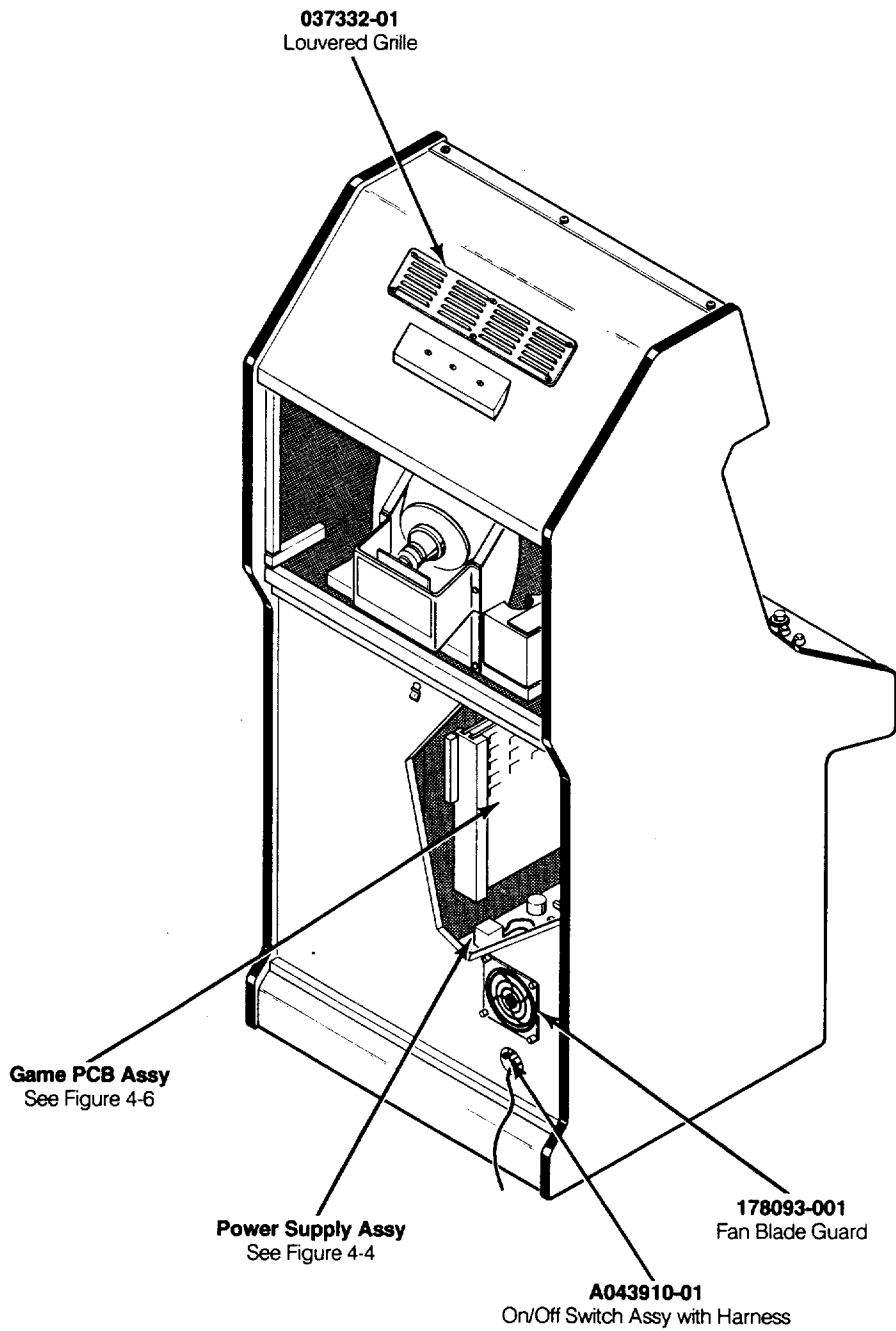
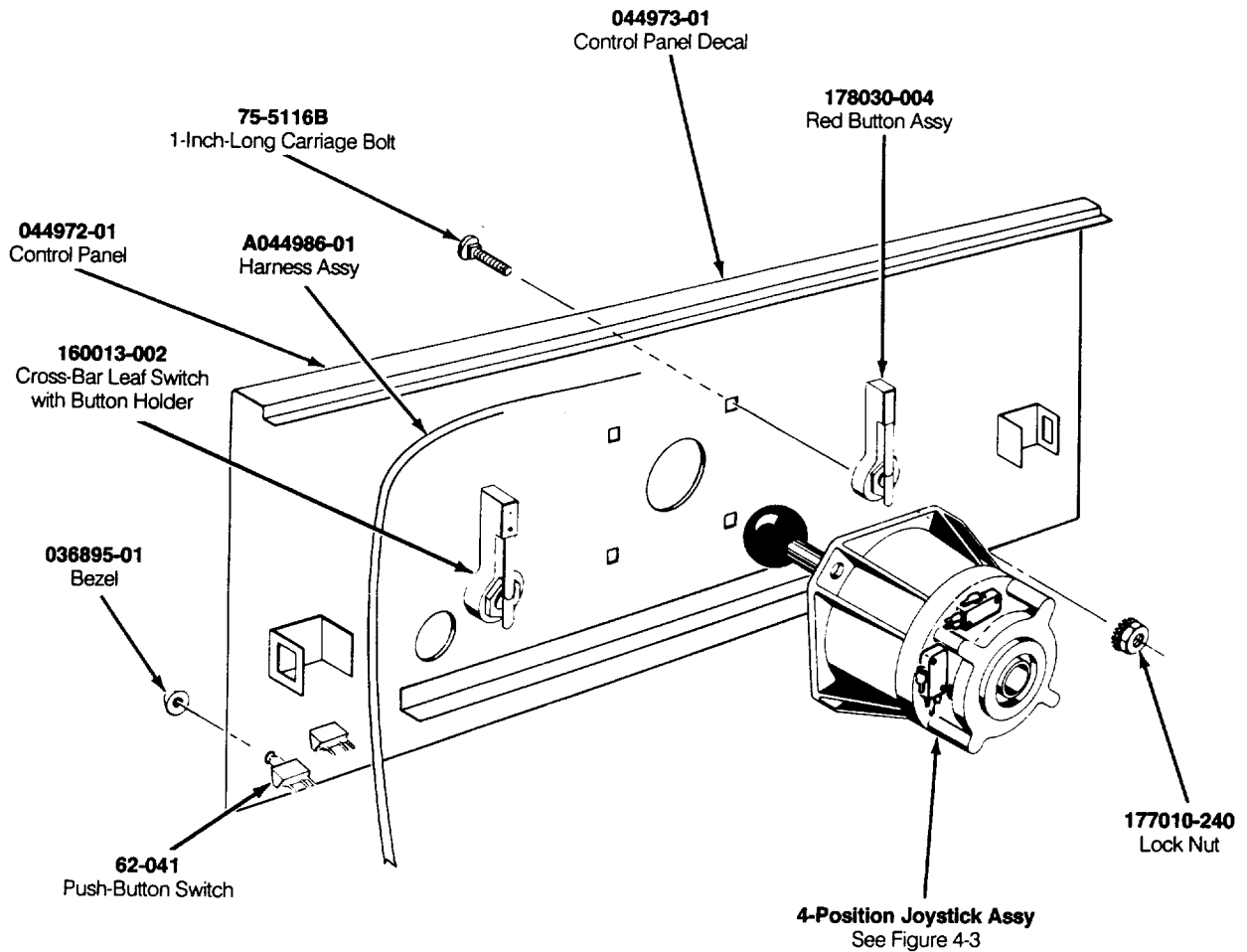

Figure 4-1 Cabinet-Mounted Assemblies, Continued

Cabinet-Mounted Assemblies Parts List

Part No.	Description
A043910-01	4-Inch-Long On/Off Switch Assembly with Harness
A044072-01	12 VDC Non-Resetable Coin Counter Assembly
A044861-01	Main Harness Assembly
A044862-01	AC Harness Assembly
A044864-01	Video Harness Assembly
A044865-01	+ 5 V Harness Assembly
A044866-01	Ground Strap Assembly
A044866-02	Ground Strap Assembly
A044977-01	Cabinet Assembly
78-3201	Adjustable Glide
78-6900402	¼-Inch-Wide × ½-Inch-Thick Foam Tape (24 inches required; used on control panel edge resting directly on display shield)
99-11006	Fluorescent Lamp Retainer Clip
034536-02	0.50-Inch-Thick Foam Vibration Damper
037332-01	Louvered Grille
038091-01	Molded Coin Box
042914-01	Ventilation Grille
043276-02	Machined Retainer
044830-01	Video Display Shield
044831-01	Ground Plate
044845-01	Rear Access Panel
044850-01	Speaker Cover Grille
044853-01	Front Access Panel
044974-01	Formed Attraction Panel
044975-01	Video Display Bezel with Graphics
139021-002	Sanyo Model 20-Z2AD 19-Inch Color Raster Video Display
148007-104	4½-Inch Round, 8Ω, 10W, Shielded Speaker
170003-001	18-Inch-Long 50 W Fluorescent Lamp
171086-001	18-Inch-Long 118 V 60 Hz Fluorescent Lamp Fixture
178013-001	Spring Draw Latch
178056-002	½-Inch-Wide × ¼-Inch-Thick Foam Tape (4 inches required; used on corners on underside of display bezel)
178093-001	Fan Blade Guard
	<i>The following items are the technical information supplements for this game:</i>
TM-315	Pac-Mania Operators Manual
SP-315	Pac-Mania Schematic Package
ST-315	Pac-Mania Self-Test Label
TM-311	Sanyo 19" Color Raster Video Display Service Manual



**Figure 4-2 Control Panel Assembly
A044971-01 B**

**Control Panel Assembly
Parts List**

Part No.	Description
A040933-01	4-Position Snap-Action Switch Joystick Assembly—see Figure 4-3
A044986-01	Control Panel Harness Assembly
62-041	Black Cap (No LED) SPDT Push-Button Switch
75-5116B	#10-24 × 1.00-Inch-Long Black Carriage Bolt
75-9910NO	#11- $\frac{3}{8}$ -Inch Stamped Nut
036895-01	Black Molded Bezel
044972-01	Control Panel
044973-01	Control Panel Decal
160013-002	Cross-Bar Leaf Switch with Button Holder
177010-240	#10-24 Lock Nut
178030-004	Red Button Assembly

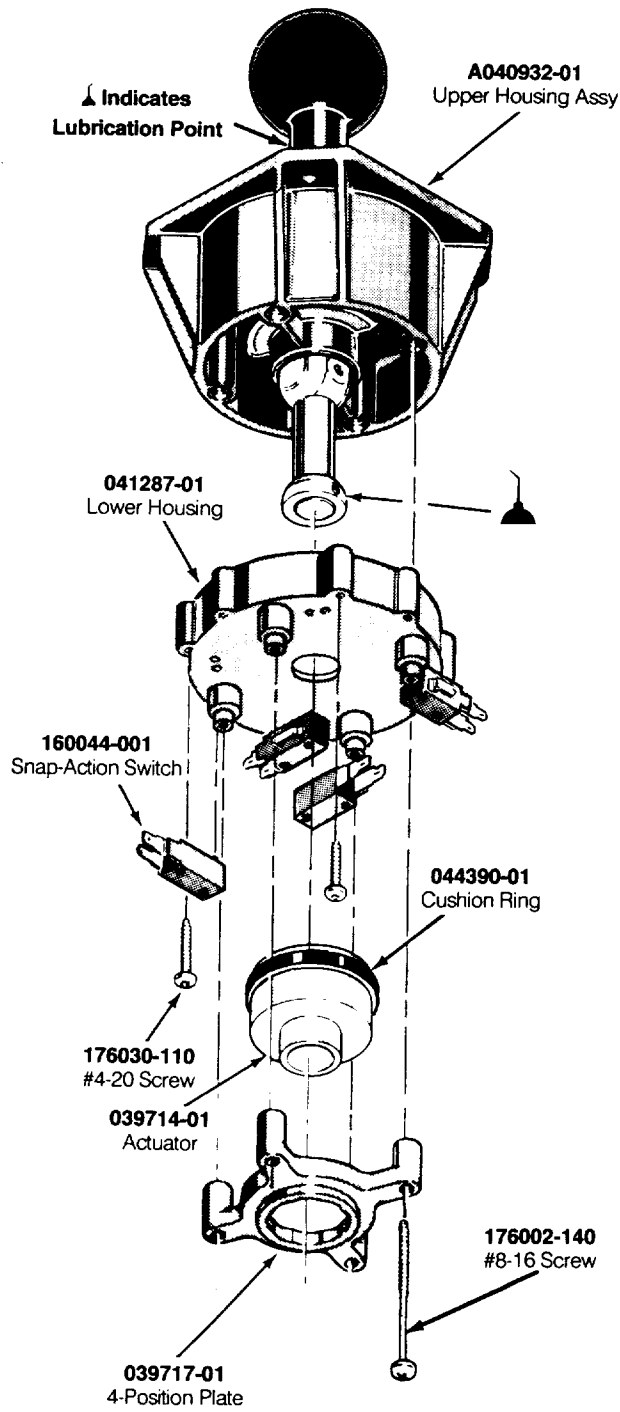

**Figure 4-3 4-Position Joystick Assembly
A040933-01 E**

4-Position Joystick Assembly Parts List

Part No.	Description
A040932-01	Upper Housing Assembly
039714-01	Actuator
039717-01	4-Position Positioner Plate
041287-01	Lower Housing
044390-01	Cushion Ring
160044-001	Snap-Action Switch
176002-140	#8-16 × 2.50-Inch-Long Self-Tapping Hex Washer-Head Screw
176030-110	#4-20 × .62-Inch-Long Self-Tapping Hex Washer-Head Screw

▲ WARNING ▲

The switching power supply has high voltages on it when power is turned on. Therefore, be sure you *do not touch this power supply* unless you have turned off the power to the game.

NOTE

The Astec 5V/12V power supply is not assembled exactly as illustrated below. The Astec power supply, all of its accompanying hardware, and the 50 Ω resistor are turned 180° from the view shown. In other words, the 5V Harness Assy. exits from the Astec power supply at the back of the power supply chassis.

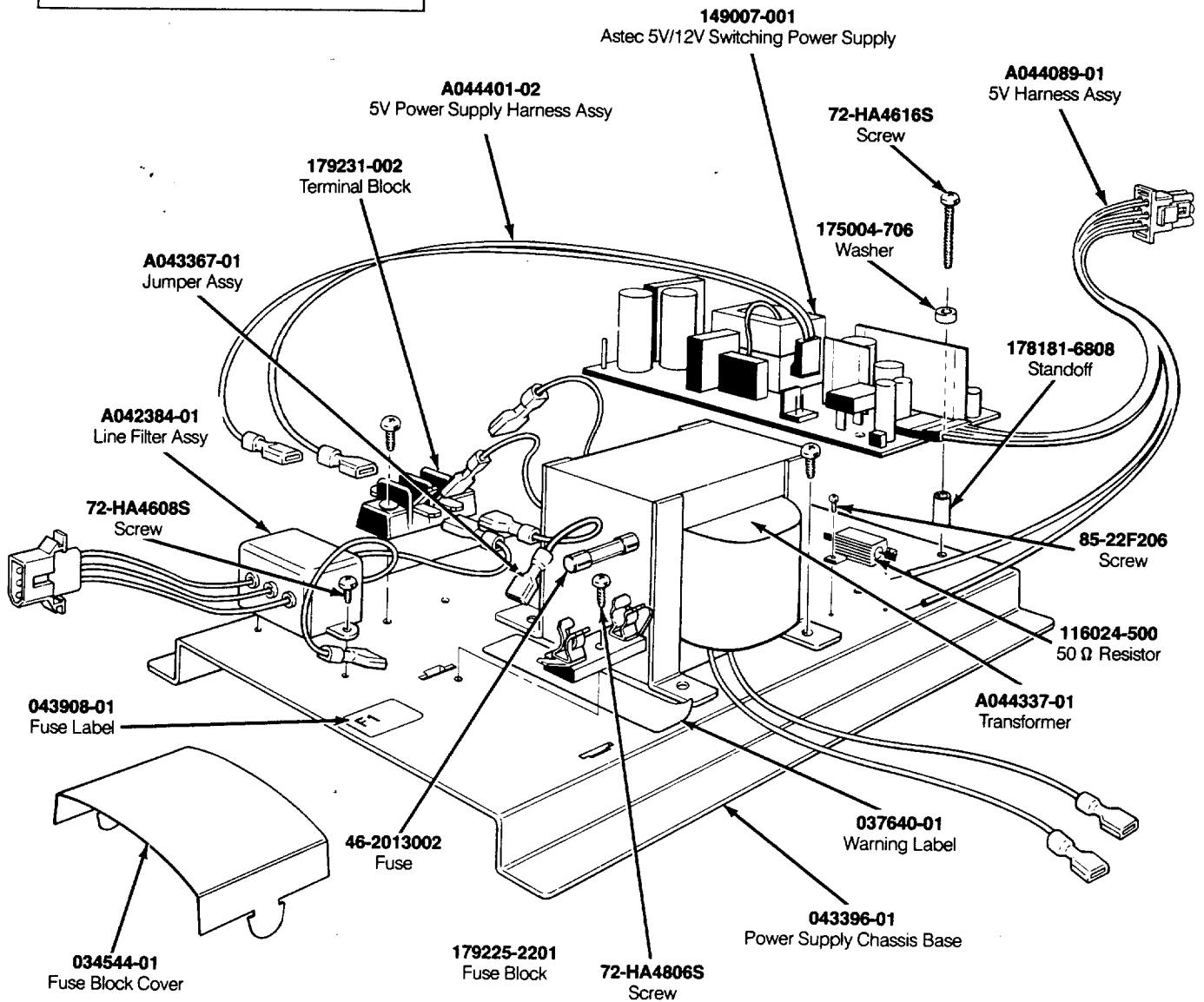

**Figure 4-4 Switching/Linear (SL) Power Supply Assembly
A04439-02 B**

Switching/Linear (SL) Power Supply Assembly Parts List

Part No.	Description
A042384-01	Line Filter Assembly
A043367-01	Jumper Assembly
A044089-01	5 V Harness Assembly
A044337-01	Transformer Termination Assembly
A044401-02	5 V Power Supply Harness Assembly
46-2013002	250 V Slow-Blow 3 A Fuse
72-HA4608S	#6-32 x 1/2-Inch Cross-Recessed Pan-Head Thread-Forming Screw
72-HA4616S	#6-32 x 1-Inch Cross-Recessed Pan-Head Thread-Forming Screw
72-HA4806S	#8-32 x 3/8-Inch Cross-Recessed Pan-Head Thread-Forming Screw
85-22F206	#2-56 x 3/8-Inch Cross-Recessed Pan-Head thread-Forming Screw
034544-01	Fuse Block Cover
037640-01	Power Supply Warning Label
043396-01	Power Supply Chassis Base
043908-01	Power Supply Fuse Label
116024-500	50 Ω , 5 W, Chassis-Mount Resistor
149007-001	Astec 5 V/12 V Switching Power Supply
175004-706	#6 Fiber Washer
178181-6808	.171-Inch ID, 1/4-Inch OD, Aluminum Standoff
179225-2201	1-Position Fuse Block
179231-002	2-Position Terminal Block

Astec 5-Volt Power Supply Sub-Assembly Model SA40-1304 Parts List

Designator	Description	Part No.
Capacitors		
C1, C2	Capacitor, Met Poly, .1 μ F, \pm 20%, 250 VAC	99-209076
C3, C4	Capacitor, Poly, 2200 pF, \pm 20%, 250 VAC	99-209077
C5	Capacitor, Met Poly, 2200 pF, \pm 20%, 250 V	99-209080
C8	Capacitor, Electrolytic, 220 μ F, + 100 - \pm 10%, 10 V	99-209072
C9	Capacitor, Ceramic, 1000 pF, \pm 20%, 3 KV, Z5P	99-209068
C10	Capacitor, Met Poly, .022 μ F, \pm 20%, 250 VAC	99-209079
C11	Capacitor, Poly, .22 μ F, \pm 10%, 100 V	99-209014
C12	Capacitor, Electrolytic, 2200 μ F, \pm 20%, 16 V, Sxa	99-209073
C13	Capacitor, Poly, .01 μ F, \pm 5%, 50 V	99-209075
C14	Capacitor, Electrolytic, 100 μ F, \pm 20%, 25 V, Sxa	99-209006
C15	Capacitor, Electrolytic, 1000 μ F, \pm 20%, 16 V, Sxa	99-209008
C16	Capacitor, Poly, .022 μ F, \pm 20%, 50 V	99-209078
C17	Capacitor, Electrolytic, 1000 μ F, \pm 20%, 10 V, Sm	99-209071
C18	Capacitor, Ceramic, 330 pF, \pm 20%, 100 V, SI	99-209069
C19	Capacitor, Electrolytic, 470 μ F, \pm 20%, 16 V, Sm	99-209074
C20	Capacitor, Electrolytic, 100 μ F, \pm 20%, 16 V, Sm	99-209070
C21	Capacitor, Poly, .22 μ F, \pm 10%, 100 V	99-209014
C23	Capacitor, Ceramic, .01 μ F, + 80- \pm 20%, 100 V, Z5U	99-209003
Diodes		
D1	Diode, RGP10A	99-209083
D2	Diode, RGP10J	99-209033

**Astec 5-Volt Power Supply Sub-Assembly
Model SA40-1304 Parts List, Continued**

Designator	Description	Part No.
D3	Diode, GP10A	99-209084
D4, D5	Diode, RGP10J	99-209033
D6, D7	Diode, 1N4606	99-209030
D8	Assembly, Regulator/SCR/Diode/Heat Sink	99-209105
D8	Diode, 12CTQ035	99-209107
D9	Diode, RGP10B	99-209034
D10	Assembly, Diode/Heat Sink	99-209103
D11	Diode, 1N4606	99-209030
D12, D13	Diode, 1N4001	99-209035
DB1	Diode, Bridge, KBP08	99-209085
Inductors		
L3	Inductor, 2.2 μ H	99-209029
L4	Inductor, 1.5 mH	99-209028
L5	Assembly, Inductor Coil	99-209059
L6	Inductor, 4.4 μ H	99-209102
Transistors		
Q1	Transistor, NPN, 2SC2120	99-209082
Q2	Assembly, Transistor/Heat Sink	99-209104
Q3	Transistor, PNP, 2SB561	99-209022
Resistors		
R1	Resistor, Carbon Film, 470K Ω , \pm 5%, $\frac{1}{2}$ W	99-209089
R2	Resistor, Wirewound, 33 Ω , \pm 5%, 3 W	99-209097
R3, R4	Resistor, Metal Oxide Film, 100K Ω , \pm 5%, 1 W	99-209054
R5	Resistor, Carbon Film, 1K Ω , \pm 5%, $\frac{1}{4}$ W	99-209086
R6	Resistor, Metal Oxide Film, 120 Ω , \pm 5%, 2 W	99-209095
R7	Resistor, Metal Film, 1 Ω , \pm 5%, 1 W	99-209025
R8	Resistor, Carbon Film, 27 Ω , \pm 5%, $\frac{1}{4}$ W	99-209040
R9	Resistor, Carbon Film, 68 Ω , \pm 5%, $\frac{1}{4}$ W	99-209090
R10	Resistor, Carbon Film, 10 Ω , \pm 5%, $\frac{1}{4}$ W	99-209037
R11	Resistor, Carbon Film, 15 Ω , \pm 5%, $\frac{1}{4}$ W	99-209087
R12	Resistor, Metal Film, .75 Ω , \pm 5%, 1 W	99-209091
R13	Resistor, Carbon Film, 5.6 Ω , \pm 5%, $\frac{1}{4}$ W	99-209046
R14	Resistor, Carbon Film, 47 Ω , \pm 5%, $\frac{1}{4}$ W	99-209043
R15, R16	Resistor, Carbon Film, 270 Ω , \pm 5%, $\frac{1}{2}$ W	99-209041
R17	Resistor, Carbon Film, 8.2 Ω , \pm 5%, $\frac{1}{4}$ W	99-209049
R18	Resistor, Carbon Film, 330 Ω , \pm 5%, $\frac{1}{4}$ W	99-209042
R19	Resistor, Carbon Film, 56 Ω , \pm 5%, $\frac{1}{4}$ W	99-209045
R20	Resistor, Carbon Film, 68 Ω , \pm 5%, $\frac{1}{4}$ W	99-209090
R21	Resistor, Carbon Film, 330 Ω , \pm 5%, $\frac{1}{4}$ W	99-209042
R22	Resistor, Carbon Film, 470 Ω , \pm 5%, $\frac{1}{4}$ W	99-209044
R23	Resistor, Metal Film, 8.2K Ω , \pm 1%, $\frac{1}{4}$ W	99-209094
R24	Resistor, Metal Film, 2.7K Ω , \pm 1%, $\frac{1}{4}$ W	99-209093
R25	Resistor, Metal Film, 18K Ω , \pm 1%, $\frac{1}{4}$ W	99-209092
R27	Resistor, Carbon Film, 22 Ω , \pm 5%, $\frac{1}{4}$ W	99-209088
R28	Resistor, Carbon Film, 10 Ω , \pm 5%, $\frac{1}{4}$ W	99-209037
R29	Resistor, Metal Oxide Film, 120 Ω , \pm 5%, 2 W	99-209095

**Astec 5-Volt Power Supply Sub-Assembly
Model SA40-1304 Parts List, Continued**

Designator	Description	Part No.
R30	Resistor, Wirewound, 15 Ω , $\pm 5\%$, 5 W	99-209096
R32	Resistor, Carbon Film, 10 Ω , $\pm 5\%$, $\frac{1}{4}$ W	99-209037
Transformers		
T1	Com Mode Transformer Assembly	99-209101
T2	Transformer, Power, AC8154	99-209100
T3	Control Transformer Assembly (J/V)	99-209058
Miscellaneous		
F1	Fuse, 2 A, 250 V	99-209081
IC1	Regulator, 431	99-209023
IC2	Assembly, Regulator/SCR/Diode/Heat Sink	99-209105
IC2	Regulator, UA7912	99-209106
SCR1	Assembly, Regulator/SCR/Diode/Heat Sink	99-209105
SCR1	Thyristor, SCR, 2N6395	99-209108
TM1, TM2	Thermistor, 8 Ω , $\pm 20\%$	99-209099
VR1	Potentiometer, Trimming, 1K Ω	99-209098
Z1	Diode, Zener, 5.6 V, $\pm 5\%$, 40 mA	99-209031

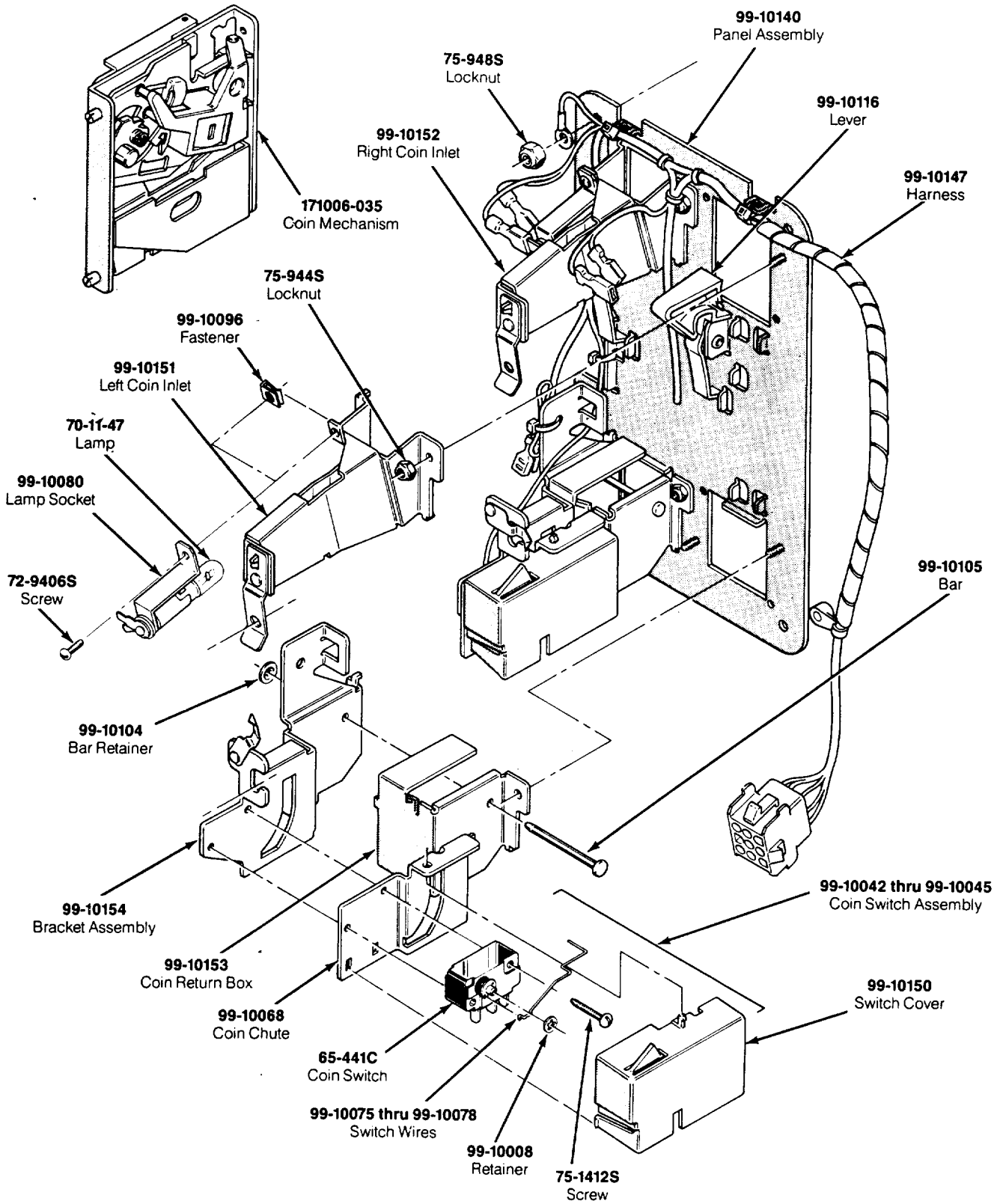

**Figure 4-5 Coin Acceptors, Inc. Coin Door Assembly
171027-001 A**

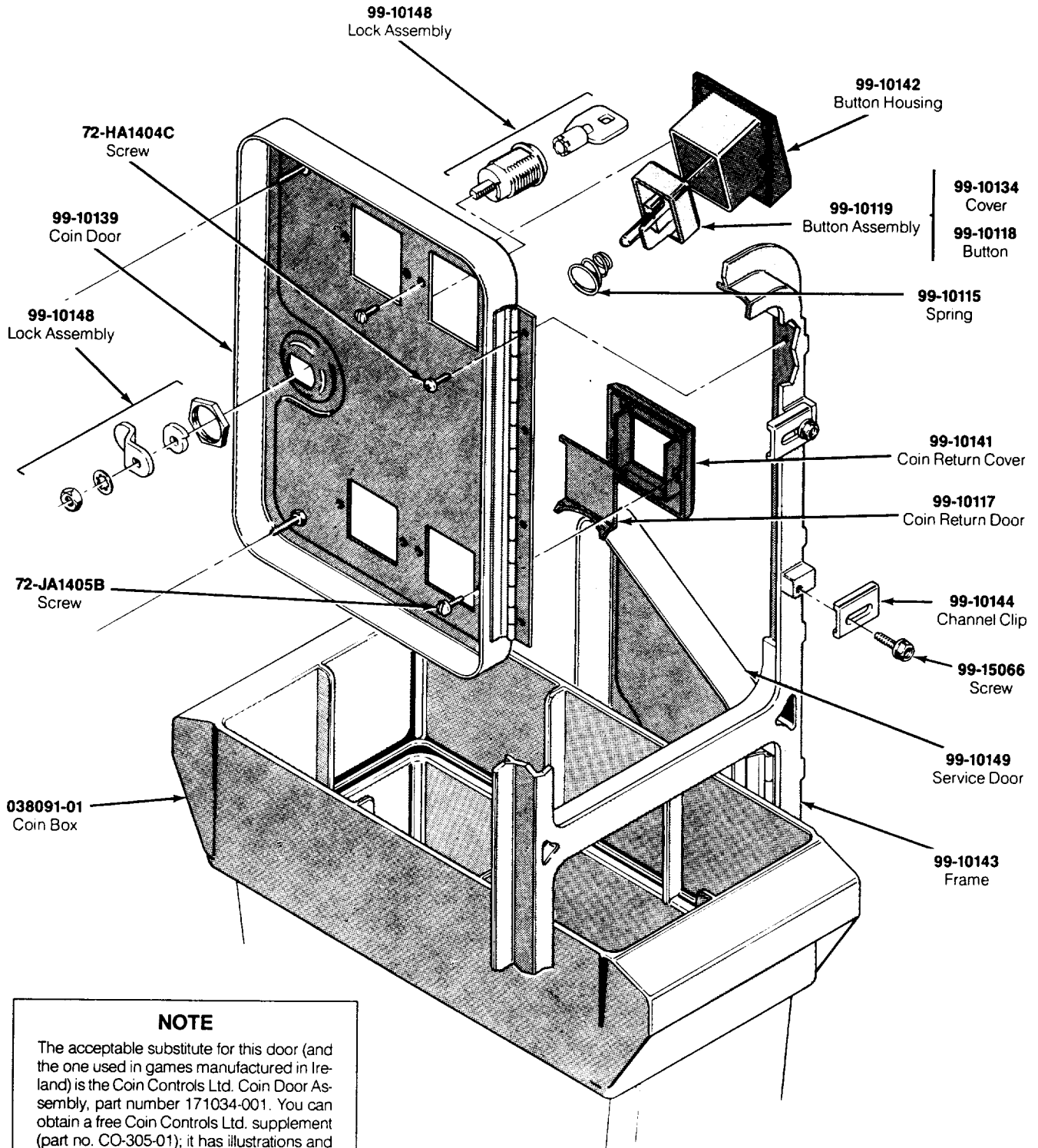

NOTE

The acceptable substitute for this door (and the one used in games manufactured in Ireland) is the Coin Controls Ltd. Coin Door Assembly, part number 171034-001. You can obtain a free Coin Controls Ltd. supplement (part no. CO-305-01); it has illustrations and a parts list. Write to Atari Games Ireland Limited, Tipperary Town, Ireland. Telephone 062-52155.

Figure 4-5 Coin Acceptors, Inc. Coin Door Assembly, Continued
171027-001 A

Coin Acceptors, Inc. Coin Door Assembly Parts List

Part No.	Description
65-441C	Coin Switch
70-11-47	Miniature Bayonet Lamp
72-9406S	#4-40 x 3/8-Inch Truss-Head Screw
72-HA1404C	#4-40 x 1/4-Inch Pan-Head Screw
72-JA1405B	#4-40 x 0.31-Inch Pan-Head Screw
75-1412S	#4-40 x 3/4-Inch Pan-Head Screw
75-994S	#4-40 Locknut
99-10008	Retainer
99-10042	Coin Switch Assembly for Belgian 5 Fr and U.S. 25¢
99-10043	Coin Switch Assembly for German 1 DM, Japanese 100 Yen, Swiss 1 Fr
99-10044	Coin Switch Assembly for German 2 DM, Italian 100 L, U.S. \$1.00
99-10045	Coin Switch Assembly for Australian \$.20, German 5 DM, British 10 P
99-10068	Coin Return Chute
99-10075	Switch Wire (included in coin switch assembly 99-10043)
99-10076	Switch Wire (included in coin switch assembly 99-10042)
99-10077	Switch Wire (included in coin switch assembly 99-10044)
99-10078	Switch Wire (included in coin switch assembly 99-10045)
99-10080	Lamp Socket
99-10081	Key Holder
99-10096	Fastener
99-10104	Bar Retainer
99-10105	Bar
99-10115	Spring
99-10116	Plastic Coin Return Lever
99-10117	Steel Coin Return Door
99-10139	Coin Door
99-10140	Coin Door Inner-Panel Assembly
99-10141	Die-Cast Coin Return Cover
99-10143	Coin Door Frame
99-10144	Channel Clip
99-10147	Harness
99-10148	Lock Assembly
99-10149	Service Door
99-10150	Switch Cover
99-10151	Left Coin Inlet
99-10152	Right Coin Inlet
99-10153	Coin Return Box
99-10154	Bracket Assembly
99-10160	1"-Wide Die-Cast Coin Inlet Housing
99-10161	25¢ Amber Side-Entry Button Assembly
99-15066	Screw for Clamp
171006-035	Metal Coin Mechanism for U.S. 25¢

N O T E S

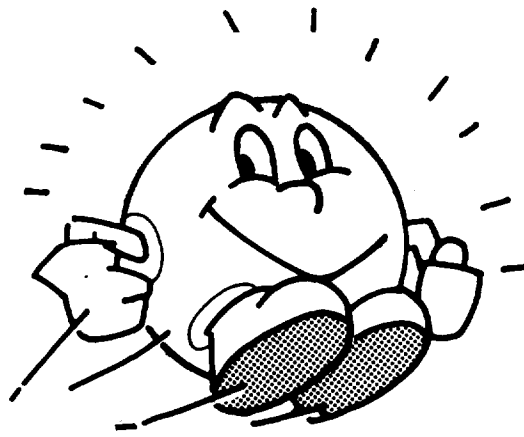

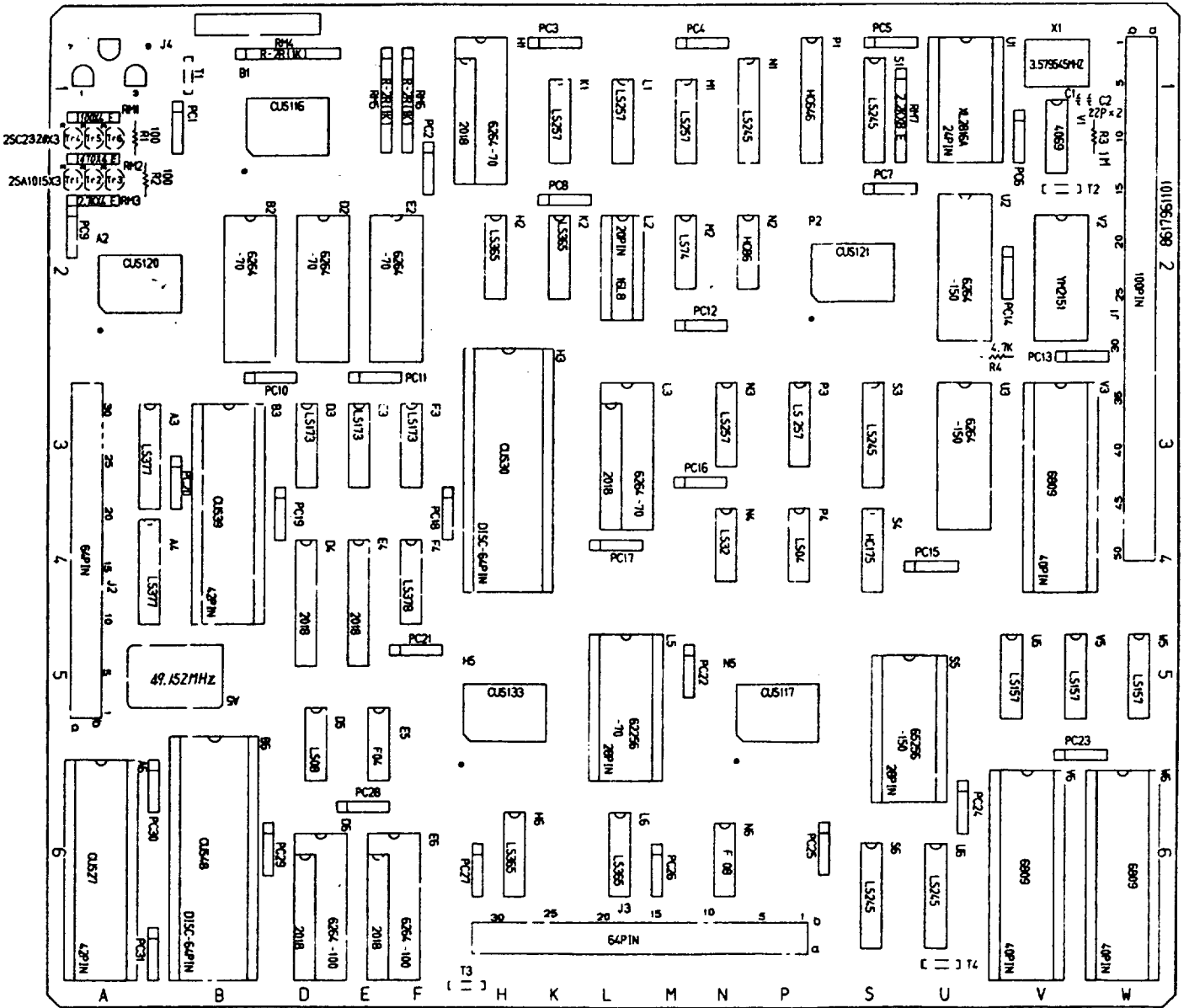

Figure 4-6A Pac-Mania CPU PCB Assembly
99-090286

Pac-Mania CPU PCB Assembly Parts List

Part No.	Description
99-090111	IC, 74LS08
99-090114	IC, 74LS32
99-090115	IC, 74LS74
99-090120	IC, 74LS157
99-090122	IC, 74LS173
99-090124	IC, 74LS245
99-090125	IC, 74LS257
99-090245	IC, 74LS365
99-090130	IC, 74LS377
99-090131	IC, 74LS378
99-090288	IC, 74F04
99-090289	IC, 74F08
99-090290	IC, 74HC86
99-090291	IC, 74HC175
99-090292	IC, 74HC646
99-090133	IC, 4069
99-090135	IC, 68A09EP
99-090134	IC, HD68A09E
99-090136	IC, TMM2018D-45 (45 ns)
99-090293	IC, TMM2064P-150 (150 ns)
99-090294	IC, M5M5165P-120 (120 ns)
99-090141	IC, TMM2064P-10 (100 ns)
99-090140	IC, M5M5165P-10 (100 ns)
99-090295	IC, TMM2018D-55 (55 ns)
99-090142	IC, M5M5165-70 (70 ns)
99-090146	IC, TMM2064P-70 (70 ns)
99-090295	IC, TMM2018D-55 (55 ns)
99-090142	IC, M5M5165-70 (70 ns)
99-090296	IC, M5M5256AP-70 (70 ns)
99-090297	IC, HM65256BP-150 (150 ns)
99-090298	IC, HM62256P-150 (150 ns)
99-090299	IC, PAL, 16L8B-2
99-090147	IC, YM2151
99-090148	IC, Custom 27
99-090149	IC, Custom 30
99-090150	IC, Custom 39
99-090154	IC, Custom 48
99-090300	IC, Custom 116
99-090301	IC, Custom 117
99-090302	IC, Custom 120
99-090303	IC, Custom 121
99-090304	IC, Custom 133
99-090194	Resistor, 4.7K Ohm, 5%, ¼ W
99-090199	Resistor, 1Meg Ohm, 5%, ¼ W
99-090262	Capacitor, Ceramic, 22 pF, 12 V
99-090175	Capacitor, Ceramic, 0.1 µF, 25 V
99-090305	Resistor, SIP, 100 Ohm, ¼ W
99-090306	Resistor, SIP, 2.7K Ohm, ¼ W

Pac-Mania CPU PCB Assembly, continued
Parts List

Part No.	Description
99-090307	Resistor, SIP, 470 Ohm, $\frac{1}{8}$ W
99-090308	Resistor, SIP, 2.2K Ohm, $\frac{1}{8}$ W
99-090309	Resistor, SIP, 1K Ohm
99-090161	Oscillator, KXO-01-49M152
99-090162	Oscillator, MCO-1425B (49.152 MHz)
99-090163	Crystal, 3.579545 MHz
99-090310	Transistor, 2SA1015-Y
99-090311	Transistor, 2SC2320-E

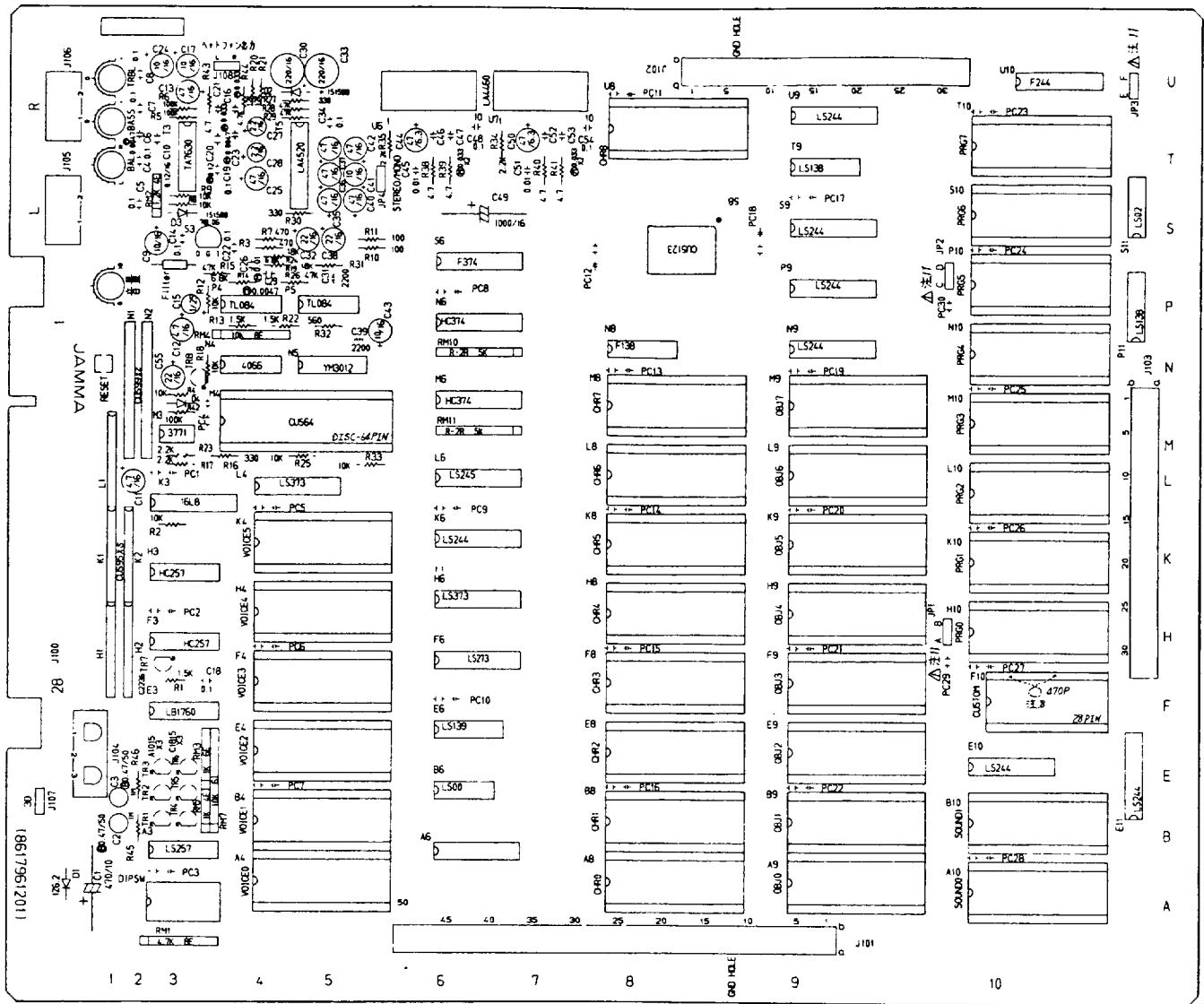

△ 注11 PRG ROM シェット切替一覧表

ROM	JP1	JP2	JP3	ROM
ピン数	容量	種類	A : B C : D E : F	例
28	512K	EP	○ <input checked="" type="checkbox"/> ○ <input checked="" type="checkbox"/> ○ <input checked="" type="checkbox"/>	27S12
28	1M	MASK	<input checked="" type="checkbox"/> ○ <input checked="" type="checkbox"/> ○ <input checked="" type="checkbox"/>	
32	1M	EP	○ <input checked="" type="checkbox"/> ○ <input checked="" type="checkbox"/> <input checked="" type="checkbox"/> ○	HN27C301
32	2M	MASK	○ <input checked="" type="checkbox"/> ○ <input checked="" type="checkbox"/> ○ <input checked="" type="checkbox"/>	
	4M	MASK	○ <input checked="" type="checkbox"/> ○ <input checked="" type="checkbox"/> ○ <input checked="" type="checkbox"/>	

Figure 4-6B Pac-Mania ROM PCB Assembly
99-090356

Pac-Mania ROM PCB Assembly Parts List

Part No.	Description
99-090108	IC, 74LS00
99-090312	IC, 74F02
99-090117	IC, 74LS138
99-090118	IC, 74LS139
99-090244	IC, 74LS244
99-090124	IC, 74LS245
99-090125	IC, 74LS257
99-090126	IC, 74LS273
99-090127	IC, 74LS373
99-090313	IC, 74F138
99-090314	IC, 74F244
99-090315	IC, 74F374
99-090246	IC, 4066
99-090132	IC, 74HC257
99-090316	IC, 74HC374
99-090317	IC, Custom 64, M4
99-090157	IC, Custom 99, N1 and N2
99-090318	IC, Custom 123, S8
99-090155	IC, Custom 95, H1, K1, L1, H2, and K2
99-090158	IC, DAC, YM3012
99-090319	IC, PAL, 16L8B-2
99-090320	IC, 78L06
99-090248	IC, Op-Amp, TL084CN
99-090160	IC, Power Amplifier, LA4460
99-090321	IC, LA4520
99-090322	IC, TA7630
99-090323	IC, LB1760
99-090324	IC, MB3771
99-090250	Diode, 1S1588
99-090325	Diode, 1S1885
99-090326	Diode, 1Z6.2
99-090327	Transistor, 2SC1815
99-090310	Transistor, 2SA1015-Y
99-090328	Transistor, 2SC2236-Y
99-090187	Resistor, 4.7 Ohm, 5%, 1/4 W
99-090255	Resistor, 100 Ohm, 5%, 1/4 W
99-090189	Resistor, 330 Ohm, 5%, 1/4 W
99-090191	Resistor, 470 Ohm, 5%, 1/4 W
99-090192	Resistor, 560 Ohm, 5%, 1/4 W
99-090329	Resistor, 1.5K Ohm, 5%, 1/4 W
99-090257	Resistor, 2.2K Ohm, 5%, 1/4 W
99-090194	Resistor, 4.7K Ohm, 5%, 1/4 W
99-090195	Resistor, 6.8K Ohm, 5%, 1/4 W
99-090196	Resistor, 10K Ohm, 5%, 1/4 W
99-090330	Resistor, 12K Ohm, 5%, 1/4 W
99-090200	Resistor, 18K Ohm, 5%, 1/4 W
99-090261	Resistor, 47K Ohm, 5%, 1/4 W
99-090331	Resistor, 100K Ohm, 5%, 1/4 W

Pac-Mania ROM PCB Assembly, continued Parts List

Part No.	Description
99-090199	Resistor, 1Meg Ohm, 5%, ¼ W
99-090332	Resistor, SIP, 1K Ohm, ⅛ W
99-090333	Resistor, SIP, 1.2K Ohm, ⅛ W
99-090334	Resistor, SIP, 1K Ohm, ⅛ W
99-090185	Resistor, SIP, 4.7K Ohm × 8, ⅛ W
99-090335	Resistor, SIP, 10K Ohm, ⅛ W
99-090336	Resistor, SIP, 10K Ohm, ⅛ W
99-090253	Resistor, SIP, 5K Ohm × 8
99-090274	Inductor, 100 µH, SP0406-101K
99-090337	Capacitor, Cer, 2200 pF, 25 V
99-090174	Capacitor, Ceramic, 0.01 µF, 25 V
99-090175	Capacitor, Ceramic, 0.1 µF, 25 V
99-090338	Capacitor, .0047 µF, 50 V
99-090339	Capacitor, .033 µF, 50 V
99-090340	Capacitor, .12 µF, 50 V
99-090341	Capacitor, .01 µF, 50 V
99-090342	Capacitor, 1 µF, 25 V
99-090343	Capacitor, Electrolytic, 47 µF, 66.3 V
99-090344	Capacitor, Electrolytic, 470 µF, 10 V
99-090345	Capacitor, Electrolytic, 2.2 µF, 16 V
99-090346	Capacitor, Electrolytic, 4.7 µF, 16 V
99-090255	Resistor, 100 Ohm, 5%, ¼ W
99-090269	Capacitor, Electrolytic, 10 µF, 16 V
99-090347	Capacitor, Electrolytic, 22 µF, 16 V
99-090270	Capacitor, Electrolytic, 47 µF, 16 V
99-090348	Capacitor, Electrolytic, 220 µF, 16 V
99-090349	Capacitor, Electrolytic, 1000 µF, 16 V
99-090350	Capacitor, Electrolytic, .47 µF, 50 V
99-090351	Potentiometer, 10K Ohm
99-090352	Switch, DIP, 8-Circuit
99-090357	IC, Custom 151, F10
136058-1101	IC, EPROM, Pac-Mania, PN1 P6, S10
136058-1102	IC, EPROM, Pac-Mania, PN1 P7, T10
136058-1103	IC, EPROM, Pac-Mania, PN1 S0, A10
136058-1104	IC, EPROM, Pac-Mania, PN1 S1, B10
136058-1105	IC, ROM, Pac-Mania, PN OBJ-0, A9
136058-1106	IC, ROM, Pac-Mania, PN OBJ-1, B9
136058-1107	IC, ROM, Pac-Mania, PN CHR-0, A8
136058-1108	IC, ROM, Pac-Mania, PN CHR-1, B8
136058-1109	IC, ROM, Pac-Mania, PN CHR-2, E8
136058-1110	IC, ROM, Pac-Mania, PN CHR-3, F8
136058-1111	IC, ROM, Pac-Mania, PN CHR-8, U8
136058-1112	IC, ROM, Pac-Mania, PN VOI-0, A4

NOTICE TO ALL PERSONS RECEIVING THIS DRAWING

CONFIDENTIAL. Reproduction forbidden without the specific written permission of Atari Games Corporation, Milpitas, CA. This drawing is only conditionally issued, and neither receipt nor possession thereof confers or transfers any right in, or license to use, the subject matter of the drawing or any design or technical information shown thereon, nor any right to reproduce this drawing or any part thereof. Except for manufacture by vendors of Atari Games Corporation, and for manufacture under the corporation's written license, no right is granted to reproduce this drawing or the subject matter thereof, unless by written agreement with or written permission from the corporation.

NOTE: Components R1-R7, TP1, and TP2 should not be installed in the PCB

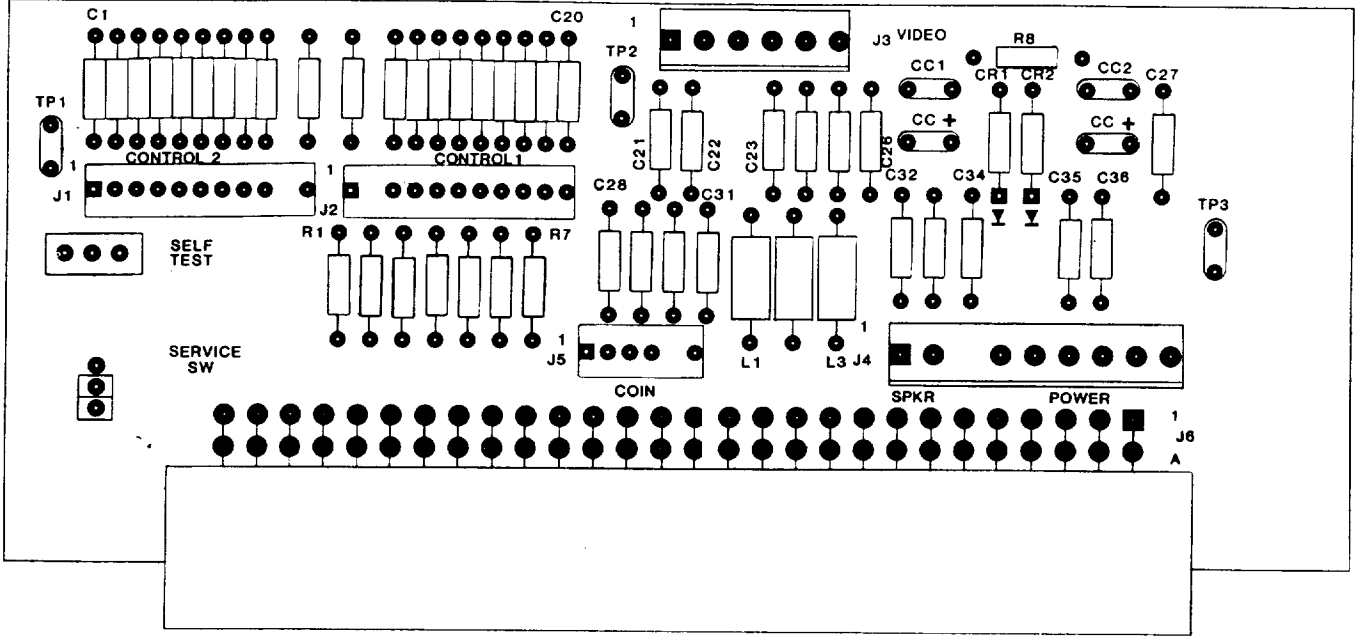

**Figure 4-7 End PCB Assembly
A044201-01 C**

**End PCB Assembly
Parts List**

Designator	Description	Part No.
Capacitors		
C1-C21	.1 μ F, 50 V Ceramic Capacitor	122002-104
C22	.001 μ F, 50 V Ceramic Capacitor	122002-102
C23-C25	470 pF, 100 V Ceramic Capacitor	122016-471
C26-C31	.1 μ F, 50 V Ceramic Capacitor	122002-104
C32, C33	.001 μ F, 50V Ceramic Capacitor	122002-102
C34-C36	.1 μ F, 50 V Ceramic Capacitor	122002-104
Diodes		
CR1, CR2	Type-1N4001 Diode	131048-001
Connectors		
J1, J2	11-Ckt., .1-Inch Ctr. Header Connector	179118-011
J3	6-Ckt., .156-Inch Ctr. Header Connector	179213-006
J4	9-Ckt., .156-Inch Ctr. Header Connector	179213-009
J5	6-Ckt., .1-Inch Ctr. Header Connector	179118-006
J6	56-Ckt., Right-Angle Edge Connector (Acceptable substitute is part no. 179240-156)	179240-056
Resistors		
R8	0 Ω , \pm 5%, 1/4 W Resistor	110005-001
Miscellaneous		
L1-L3	Ferrite Bead	141003-005
CC +, CC +	Test Point, .187 \times .031	179051-001
TP3	Test Point, .250 \times .031	179051-003
	SPDT Miniature Slide Self-Test Switch	160040-001
	Momentary Push-Button Switch (Service Switch)	160046-001

Pac-Mania* Auto Data Sampling (A.D.S.) Game Statistics

Date: _____

Play Time Range Data (Play Time Record)

Range in Seconds	Number Eliminated	Range in Seconds	Number Eliminated
00:00-29	_____	00:30-59	_____
01:00-29	_____	01:30-59	_____
02:00-29	_____	02:30-59	_____
03:00-29	_____	03:30-59	_____
04:00-29	_____	04:30-59	_____
05:00-29	_____	05:30-59	_____
06:00-29	_____	06:30-59	_____
07:00-29	_____	07:30-59	_____
08:00-29	_____	08:30-59	_____
09:00-29	_____	09:30-59	_____
10:00-29	_____	10:30-59	_____
11:00-29	_____	11:30-59	_____
12:00-29	_____	12:30-59	_____
13:00-29	_____	13:30-59	_____
14:00-29	_____	14:30-59	_____
15:00-29	_____	15:30-59	_____
16:00-29	_____	16:30-59	_____
17:00-29	_____	17:30-59	_____
18:00-29	_____	18:30-59	_____
19:00-29	_____	19:30-	_____

Pac-Man Dead Round Data (Miss Round Record)

Rnd	No. Eliminated	Rnd	No. Eliminated	Rnd	No. Eliminated
1	_____	2	_____	3	_____
4	_____	5	_____	6	_____
7	_____	8	_____	9	_____
10	_____	11	_____	12	_____
13	_____	14	_____	15	_____
16	_____	17	_____	18	_____
19	_____	20	_____	21	_____
22	_____	23	_____	24	_____

Game Over Round Data (Over Round Record)

Rnd	No. Eliminated	Rnd	No. Eliminated	Rnd	No. Eliminated
1	_____	2	_____	3	_____
4	_____	5	_____	6	_____
7	_____	8	_____	9	_____
10	_____	11	_____	12	_____
13	_____	14	_____	15	_____
16	_____	17	_____	18	_____
19	_____	20	_____	21	_____
22	_____	23	_____	24	_____

*Pac-Mania is engineered and designed by Namco Ltd.
 Manufactured by Atari Games. Trademark and © Namco 1987.

