

MOON SHUTTLE

T.M.



©1981
Trade Marks of Taito America Corporation

72-00007-001

“MOON SHUTTLE”™ UPRIGHT

TABLE OF CONTENTS

1. “MOON SHUTTLE”™ UPRIGHT GAME SET-UP	Page 2
A. Introduction	2
B. Game Inspection	2
C. Game Installation	2
D. Dip Switch and Volume Control Settings	2
2. MAINTENANCE	3
A. Cleaning	3
B. Fuse Replacement	3
C. Video Monitor Removal	3
D. Video Monitor Adjustments (Separate Manual)	3
E. Fluorescent Bulb Replacement	3
F. Printed Circuit Board Replacement	3
3. ILLUSTRATIONS AND PART LISTS	
Figure 1 Option Switch & Volume Control Locations	3
Figure 2 Switching Regulator	4
Figure 3 Fluorescent Bulb Panel	6
Figure 4 PCB Mounting Assembly	7
Figure 5 Video & Cabinet Assembly	8
Figure 6 Coin Mechanism & Front Door Assembly	10
Figure 7 Control Panel	12
Figure 8 5-Way Joystick Assembly	13
Figure 9 PC CPU Board “B” Layout	14
Figure 10 PC Game Board “A” Layout	16
Figure 11 Wiring Diagram	18
Figure 12 Game Board “A” Schematic Fold-Out	
Figure 13 CPU Board “B” Schematic Fold-Out	

"MOON SHUTTLE"™ UPRIGHT

1. GAME SET-UP

A. INTRODUCTION

TAITO AMERICA'S CORPORATION'S "MOON SHUTTLE"™ upright is an electronic video arcade game designed for one or two players.

The object of the game is to destroy the attacking Centrons, Electric Jelly, Plasma Jacks (which divide when hit) and the Retons which are worth extra bonus points. Also to maneuver the players spaceship through the meteor belt safely.

The player has the ability to move his spaceship upward and downward to avoid a collision, also to the right to speed the spaceship through the meteor belt, this can be accomplished only in the meteor sequences. The FIRE button is used to destroy the aliens and the meteors in order to provide a path through the meteor belt. The players spaceship has unlimited firing power. As the screens progress some of the meteors have more vertical movement than others which makes it more difficult to avoid a collision.

The band of meteors of various shapes and sizes move toward the player at varied speeds. Sometimes these meteors will split into smaller pieces. The player has to fire enough times and with enough accuracy to create his own path through the meteor belt. If the players spaceship should collide with a meteor it would be destroyed. The challenge of the meteor belt gets more difficult with each meteor sequence.

A smaller spaceship appears randomly hidden among the meteors in the meteor belt sequence, if the players should destroy this spaceship and additional spaceship would be awarded him.

"MOON SHUTTLE" has a Mega-Score Feature which gives the player the capability of adding extra spaceships by inserting additional coins once the game is in play.

B. GAME INSPECTION

TAITO AMERICA'S CORPORATION'S "MOON SHUTTLE"™ upright game is ready to play when received. However, careful inspection is necessary to insure your game is in perfect condition. Please verify the following before turning the game on.

- * Examine external parts for chips, dents, or broken parts.
- * Open the service door and examine the following:
 - * Plug-in connectors to make sure they are firmly seated.
 - * Speaker
 - * Player controls
 - * Printed circuit boards making sure there is no damage to the components.
 - * Check for loose foreign objects especially metal objects which may cause electrical problems.
 - * Fuses, making sure they are firmly seated in the holders.
 - * Coin Mechanisms

The Video Monitor is properly adjusted before shipping. If there are any adjustments necessary refer to our Video Monitor Manual (72-00003-001).

If problems occur or technical assistance is required, contact our Customer Service Department HOT LINE To!! Free 800-323-0666 (except Illinois). Illinois phone 312 981-1000 X215.

POWER REQUIREMENTS

TAITO AMERICA CORPORATION'S "MOON SHUTTLE"™ upright game is shipped ready for operation at 120VAC, 60Hz with a power consumption of approximately 250 Watts.

CAUTION

For safe operation it is recommended the cabinet be grounded. This game is equipped with a three conductor power cable. The third conductor is the ground conductor and when the cable is plugged into an appropriate receptacle, the game is grounded. The offset pin on the power cable's three-prong connector is the ground connection.

LOCATION SPACE REQUIREMENTS

Depth - 35" (87.5cm)
Width - 24" (61 cm)
Height - 68" (171 cm)
Weight - 300 lbs.
(Packaged Weight)

D. DIP SWITCH AND VOLUME CONTROL SETTING

DIP SWITCH SETTINGS

TAITO AMERICA'S "MOON SHUTTLE" game provides the following option switches. See Figure 1. These options can be found on the Game Board "A".

SW 1 and SW2 are used for selecting the number of rockets.

ROCKETS	SW1	SW2
3	OFF	OFF
4	ON	OFF
5	OFF	ON
6	ON	ON

SW3 is used to set the bonus level. If SW3 is in the OFF position the bonus level is 15,000 points, if in the ON position bonus level is 30,000 points.

SW4 and SW5 are used for coin selection.

COIN SELECTION	SW4	SW5
1 Coin - 1 Credit	OFF	OFF
2 Coins - 1 Credit	ON	OFF
3 Coins - 1 Credit	OFF	ON
4 Coins - 1 Credit	ON	ON

SW6, SW7, SW8 are normally in the ON position, when in the OFF position are used for a FREE play.

OPTION SWITCH & VOLUME CONTROL LOCATIONS

FIGURE 1

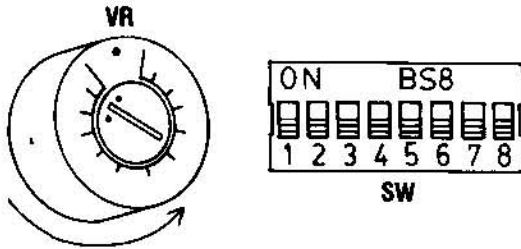

VOLUME CONTROL SETTING

The Volume Control is located on the Game Board "A", when turned as indicated in Figure 1 the volume increases.

2. MAINTENANCE

All games require a certain amount of maintenance to keep them in good condition. A periodic check of mechanical controls would be beneficial to guarantee your game will be profitable.

A. CLEANING

The exterior of the game, all metal parts and all plastic parts can be cleaned with a non-abrasive cleanser. Caution should be used when cleaning the plastic, a dry cloth can cause scratches and result in a foggy appearance.

B. FUSE REPLACEMENT

This game uses six fuses, 5 are located on the Switching Regulator. See Figure 2 for size and part number of fuses. One fuse is located on the Power Supply itself.

C. VIDEO MONITOR REMOVAL

If you need to remove the Video Monitor, follow the instructions listed below:

CAUTION

It is recommended the game be left disconnected for at least one hour before removing the video monitor. This will probably discharge the video tube but EXTREME CAUTION is still necessary.

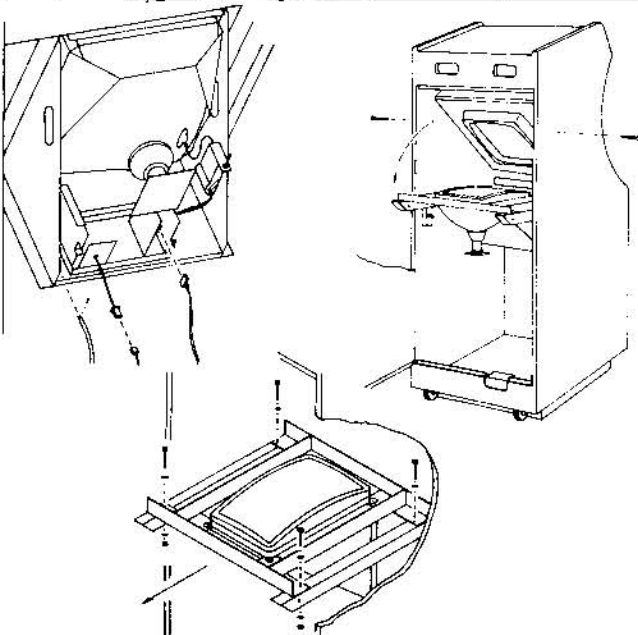

- * Disconnect power from the line voltage.
- * Disconnect the monitor cable connector.
- * Remove the wire cable clamp.
- * Take out the two side bolts, one on each side of the cabinet.
- * Remove the four mounting bolts and disconnect the green ground wire.
- * Slide the Monitor out by pulling the Monitor toward you.

CAUTION

Use EXTREME CAUTION and do not touch electrical parts of the Monitor Yoke area with your hands or with any metal object in your hands! High voltages may exist in any Monitor, even with power disconnected.

D. VIDEO MONITOR ADJUSTMENTS

TAITO AMERICA CORPORATION presently uses either a Wells-Gardner Corporation or Electrohome 19" color Video Monitor in the "MOON SHUTTLE"™ upright game. Refer to the Monitor Manual (72-00003-001) for your specific Monitor. Be sure to heed all the WARNINGS and CAUTION INSTRUCTIONS provided before repairing or replacing your Video Monitor.

E. FLUORESCENT TUBE REPLACEMENT

CAUTION

If you drop a fluorescent tube and it breaks, it will explode! PLEASE USE CARE WHEN REPLACING. See Figure 3.

- * Remove the three (3) screws from the marquee bracket, being sure to hold the glass while removing the screws.
- * Remove the Marquee glass and the Fluorescent Bulb is accessible.
- * With both hands turn the bulb toward you, carefully pull the lamp out of the lamp socket.

F. PRINTED CIRCUIT BOARD REPLACEMENT

You may wish to remove the "MOON SHUTTLE"™ upright printed circuit boards for replacement or servicing. See Figure 4 to remove the "MOON SHUTTLE"™ upright board set. Disconnect the G Connector and then Disconnect the Video Connector. Pull the board set toward you and out of the wooden cleats.

WARNING

This equipment generates, uses, and can radiate radio frequency energy and if not installed and used in accordance with the instruction manual, may cause interference to radio communications. As temporarily permitted by regulation it has not been tested for compliance pursuant to Subpart J of Part 15 of FCC Rules, which are designed to provide reasonable protection against such interference. Operation of this equipment in a residential area is likely to cause interference in which case the user at his own expense will be required to take whatever measures may be required to correct the interference.

SWITCHING REGULATOR

FIGURE 2

ITEM	TAITO PART NO.	DESCRIPTION
1	800010	Switching Regulator
2	998702	Shield Box
3	22B00001-001	Line Filter
4	26-00003-001	Service Outlet
5	24-00002-001	Fuse, 3 AMP, 3AG, Slo-Blo
6	24-00001-001	Fuse Holder
7	35-00001-001	Barrier Strip - 8 Position
8	42C00034-001	Power Mounting Board
9	29B00005-001	Interlock Switch
10	29B00004-001	Toggle Power Switch
11	35A00004-001	Insulator
12	61A00029-001	Toggle Switch Bracket
13	18A00001-001	Isolation Transformer
14	019501	Noise Filter
15	998703	Shield Cover
16	61B00030-001	Interlock Switch Bracket
*17	35B00002-001	Insulating Shield
*18	850005	Switching Regulator Assembly

* Note: Item is not shown on drawing

SWITCHING REGULATOR

FIGURE 2

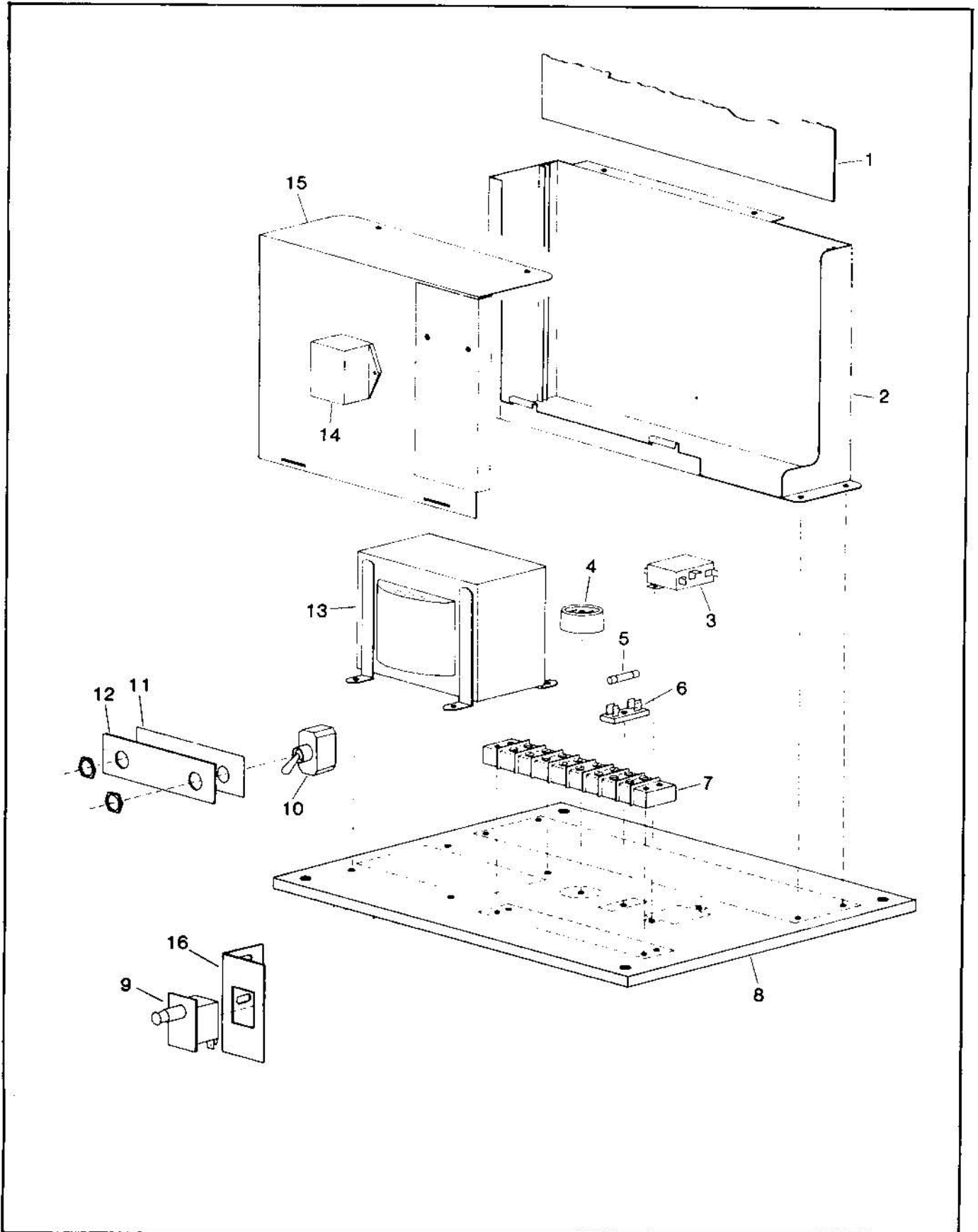

FLOURESCENT BULB PANEL

FIGURE 3

ITEM	TAITO PART NO.	DESCRIPTION
1	27-00001-001	Flourescent Tube, STD 15W
2	18-00002-001	Ballast Transformer (120V, 60Hz)
3	29-00003-001	Starter
4	26-00005-001	Starter Socket
5	26-00004-001	Lamp Socket
6	42800057-001	Flourescent Lamp Panel

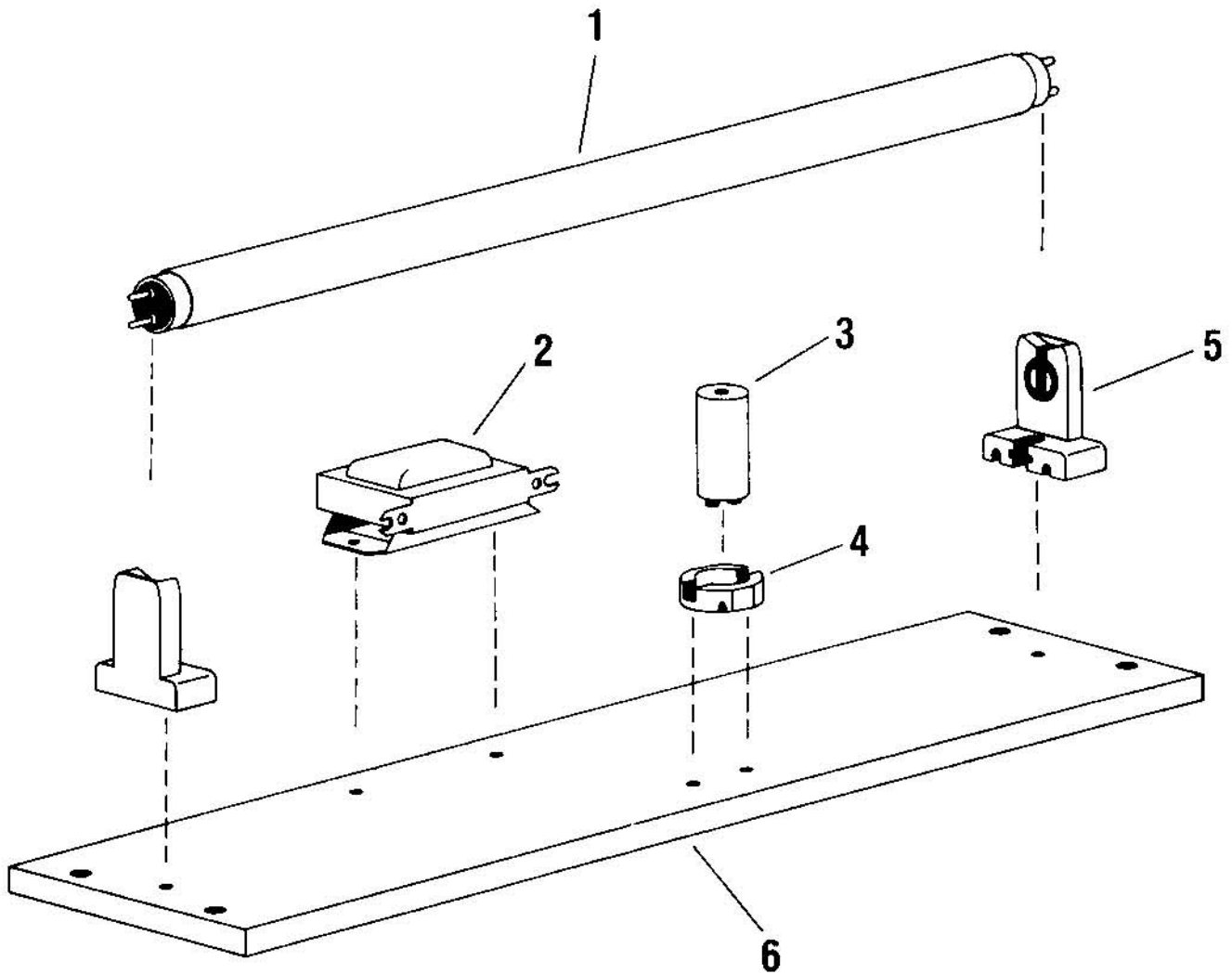

PCB MOUNTING ASSEMBLY

FIGURE 4

ITEM	TAITO PART NO.	DESCRIPTION
1	998843	PCB CPU Board "B"
2	998844	PCB Game Board "A"
3	59800030-001	Mounting Clip
4	25-00016-001	VV Connector, 6 Position
5	42C00062-001	Wood Mounting Cleat
6	25-00015-001	G Connector, 44 Position
7	08M00015-001	PCB Board Set "Moon Shuttle"

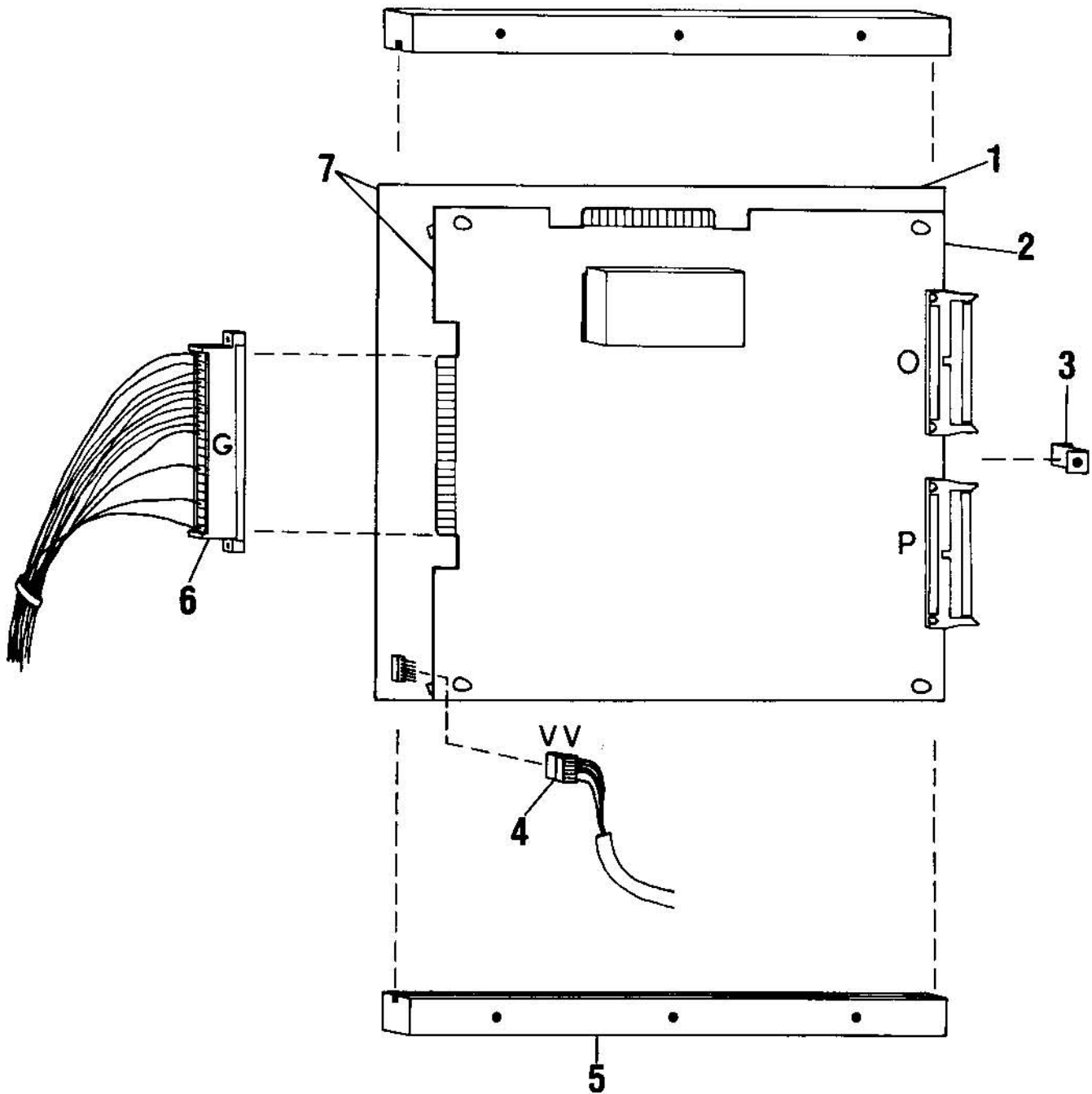

VIDEO & CABINET ASSEMBLY

FIGURE 5

ITEM	TAITO PART NO.	DESCRIPTION	REFERENCE
1	47C00001-004	Screened Marquee	
2	27-00001-001	Fluorescent Tube, Std., 15W	
3	42B00057-001	Fluorescent Lamp Panel	140006
4	26-00004-001	Lamp Socket	113000
5	61C00007-001	Marquee Retainer	500024
6	26-00005-001	Starter Socket	114001
7	29-00003-001	Starter	114000
8	18-00002-001	Ballast Transformer	
9	61B00011-001	"L" Bracket	
10	41B00002-004	Cabinet	
11	63-00002-001	"T" Molding	400007
12	59-00008-001	Clamp Fastener	390002
13	47D00002-003	Screen Cover Glass	
14	63C00003-001	Monitor Shroud	400005
15	61C00016-001	Glass Retaining Bracket	500022
16	44C00001-001	Wheel Assembly	520000
17	63B00005-002	"L" Molding, Black, 22½" Long	400031-A
18	63B00005-003	"L" Molding, Black, 3¾" Long	400031-B
19	31-00001-002	Electrohome Monitor, 19" Color	620007
19A	31-00002-002	Wells-Gardner Monitor, 19" Color	
20	61C00080-001	Video Mounting Bracket	
21	45-00001-001	Anchor Plate	600005-C
22	45-00001-001	Lock & Key	600005
23	42C-00035-001	Cabinet Back	143003
24	61B00027-001	Grill	500074
25	500086	Mounting Bracket (Top)	
26	500088	Cash Box	AA028507
27	400050	Cash Case	AA028506
28	600007	Lock Plate	AA013593
29	500089	Cash Box Door	AA026512
30	600006	Lock (Cash Box) & Key	AA016545
31	500060	Coin Funnel	AA025510
32	500061	Coin Funnel Plate	AA013690
33	115000	Counter, 6V DC	AA013608
34	500091	Counter Bracket	
35	63B00006-004	"U" Channel	400025
36	500087	Bottom Bracket	
37	36-00005-001	Counter Drive Credit Board	800011
38	25-00014-001	10 Position Edge Connector	
39	61A00014-001	Credit Board Bracket	
*40	08M00015-001	PCB Board Set "MOON SHUTTLE"	
*41	998843	Game Board (B)	
*42	998844	CPU Board (A)	
*43	42C00013-001	Monitor Cleat	
*44	61C00086-001	Corner Bracket (Monitor Mounting)	
*45	07-00005-001	Speaker	

VIDEO & CABINET ASSEMBLY

FIGURE 5

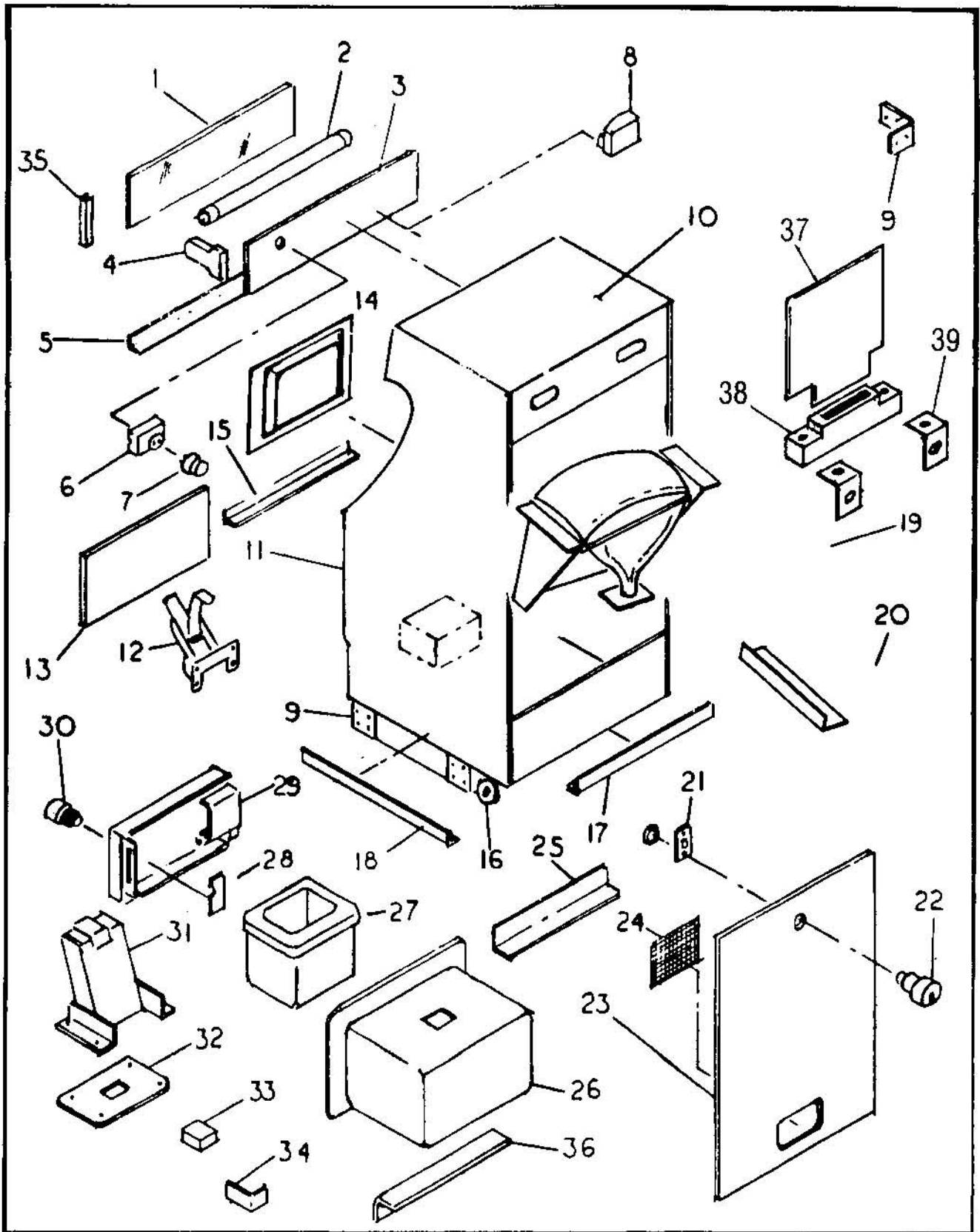

COIN MECHANISM AND FRONT DOOR ASSEMBLY

FIGURE 6

ITEM	TAITO PART NO.	DESCRIPTION	REFERENCE
1	500010	Door Frame	AA026510
2	79-50005-001	Price Card U.S. 25*	AA029512
3	27-00002-001	Pilot Lamp, 12V, 150Ma	AA054704
4	113001	Vinyl Socket	AA055698
5	61A00051-001	Coin Entry Plate for 25*	
6	600006	Service Lock & Key No. 7900	AA016558
7	79A00016-001	TAITO Name Tag	
8	500009	Coin Rejection Door	AA026511
9	500021-E	Cover Plate	AA019522
10	104000	Mate-N-Loc Pin A	AA055789
11	103007	Mate-N-Loc Housing 9 Pin	AA055581
12	103008	Mate-N-Loc Housing 9 Pin	AA055582
13	104001	Mate-N-Loc Pin 1B	AA055790
14	500021-I	Lock Plate	AA013578
15	500021-G	Coin Guide (B)	AA025508
16	500021-H	Coin Guide (A)	AA025507
17	500021-J	Tilt Switch	AA068717
18	61-00041-001	Lock Guard	AA013577
19	500021-K	Rejection Button	AA027504
20	500021-L	Spring Cancel Holder	AA015504
21	024501	Service Switch	
22	500021-M	Cancel Lever	AA013557
23	500021-N	Rejector Bracket	AA013554
24	500021-P	Rejector Holder	AA023501
25	500054	Coin Guide	AA025503
26	199005	Insulator	AA019502
27	29-00007-001	Micro Switch	AA052512
28	370002	Actuator	AA053501
29	500021-R	Rejector Lever Connector	
30	59-00018-001	Coin Acceptor	

COIN MECHANISM AND FRONT DOOR ASSEMBLY

FIGURE 6

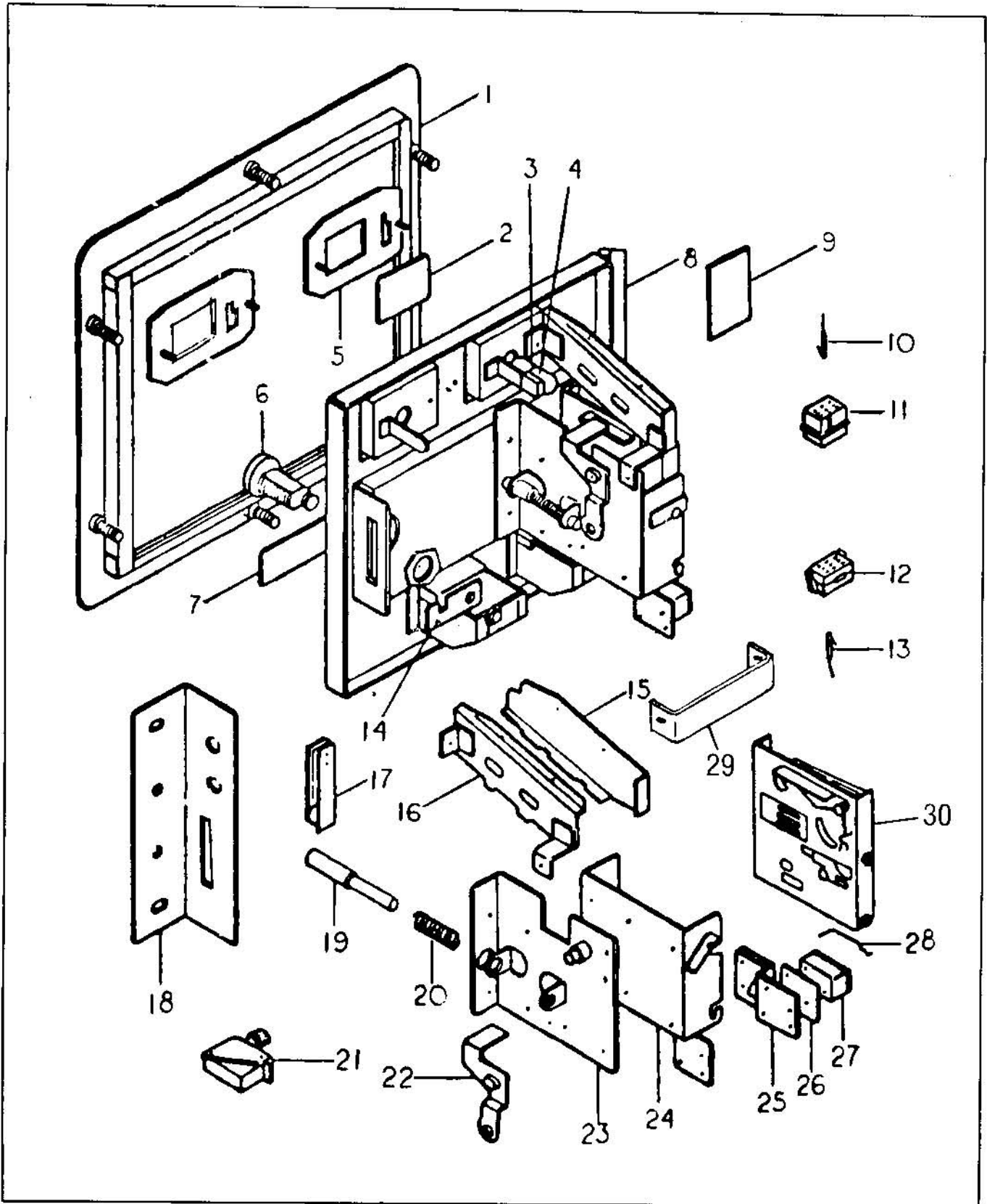

CONTROL PANEL

FIGURE 7

ITEM	TAITO PART NO.	DESCRIPTION
1	04M00032-001	Ball & Shaft Kit
2	29-00009-002	Push Button (Red)
3	29-00009-001	Push Button (White)
4	47D00014-001	Control Panel (Screened)
5	47D00109-001	Control Panel (Wood)
6	61A00015-001	Strike Hook
7	29-00014-001	Microswitch
8	63D00032-008	5-Way Control Assembly

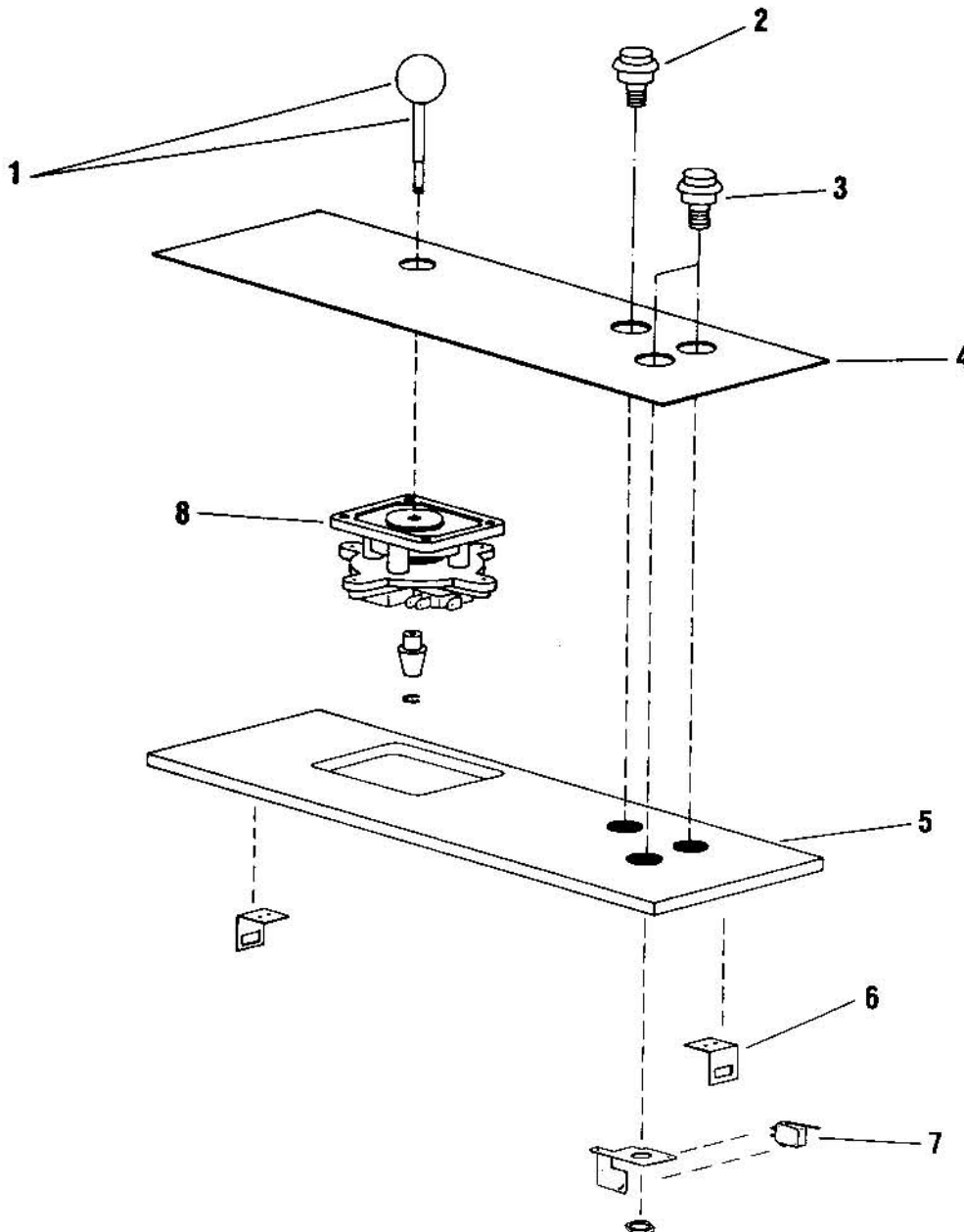

5-WAY JOYSTICK

FIGURE 8

ITEM	TAITO PART NO.	DESCRIPTION
1	63A00031-001	Ball & Shaft
2	63A00033-001	Mask
3	63C00027-003	Mounting Plate
4	62A00002-001	Shock Mount Plate
5	63C00028-003	Switch Plate
6	63A00030-001	Actuator
7	29-00014-001	Micro Switch
8	63A00029-001	Spacer
9	59A00020-017	"E" Ring

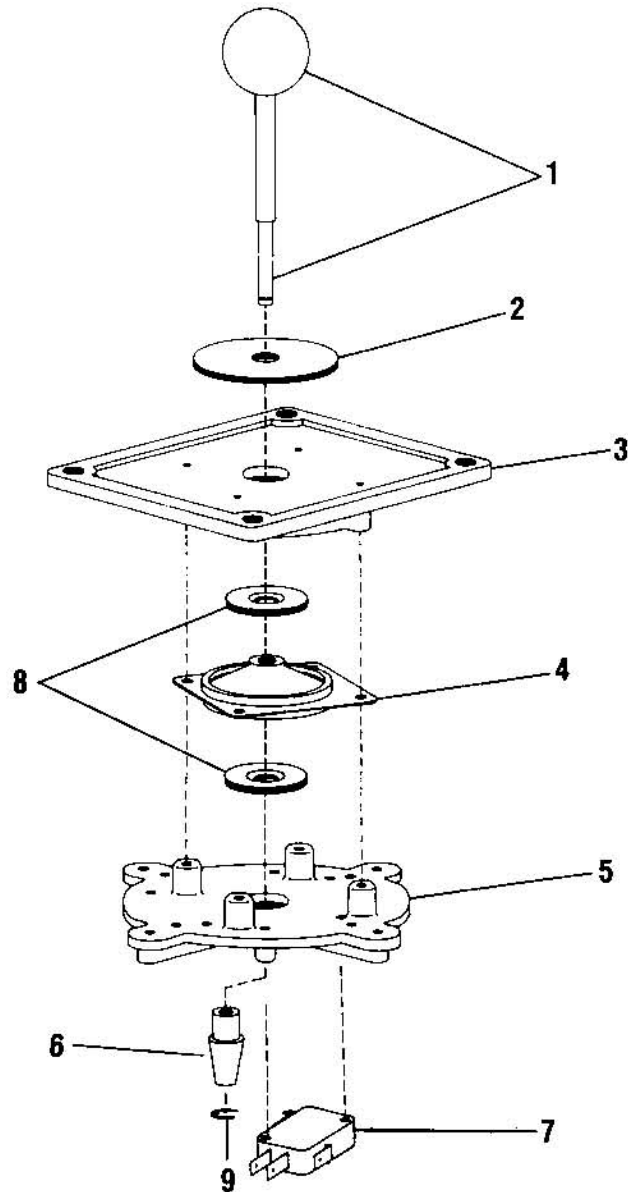

CPU BOARD LAYOUT

FIGURE 9

SYM	TAITO PART NO.	DESCRIPTION
40P	MY000163	Plug FCN-364J040-AG
DS	AA052566	Dip Switch DSS-8
50P	AA055154	Angle Pin Header PS-50PA
IS1	AA055787	IC Socket, 2P
IS2	AA055812	IC Socket, 40P
	AA069557	Locking Circuit Board Support LCB-8
D	AAT12025	Diode, IS1588
OP1	AAT31011	OP Amplifier, LM3900
OP2	AAT31042	OP Amplifier, MB3712
IC1	AAT32163	Static RAM, 2114-2
IC2	AAT32165	Sound IC, AY3-8910
IC3	AAT33001	LSIC, 74LS00
IC4	AAT33003	LS IC, 74LS02
IC5	AAT33005	LS IC, 74LS04
IC6	AAT33009	LS IC, 74LS08
IC7	AAT33027	LS IC, 74LS32
IC8	AAT33032	LS IC, 74LS42
IC9	AAT33051	LS IC, 74LS51
IC10	AAT33089	LS IC, 74LS125
IC11	AAT33096	LS IC, 74LS138
IC12	AAT33097	LS IC, 74LS139
IC13	AAT33112	LS IC, 74LS157
IC14	AAT33116	LS IC, 74LS161
IC15	AAT33127	LS IC, 74LS174
IC16	AAT33157	LS IC, 74LS245
IC17	AAT33166	LS IC, 74LS259
IC18	AAT33170	LS IC, 74LS273
IC19	AAT33203	LS IC, 74LS367

SYM	TAITO PART NO.	DESCRIPTION
IC20	AAT33204	LS IC, 74LS368
IC21	AAT33220	LS IC, 74LS393
IC22	AAT36067	C-MOS IC, CD4066
ROM1	MY000164	P-ROM (2732) MY01
ROM2	MY000165	P-ROM (2732) MY02
ROM3	MY000166	P-ROM (2732) MY03
ROM4	MY000167	P-ROM (2732) MY04
ROM5	MY000168	P-ROM (2732) MY05
ROM6	MY000169	P-ROM (2732) MY06
ROM7	MY000170	P-ROM (2732) MY07
C1	AAT41035	Cap, Electrolytic, 25VB47
C2	AAT41036	Cap, Electrolytic, 25VB100
C3	AAT41039	Cap, Electrolytic, 25VB470
C4	AAT41430	Cap, Electrolytic, SSG25-10F
C5	AAT41709	Cap, Ceramic 0.001uf, 12V
C6	AAT41713	Cap, Ceramic 0.1uf, 25V
R1	AAT51749	RES, Carbon 220 OHM 1/4W ±5%
R2	AAT51765	RES, Carbon 1K OHM 1/4W ±5%
R3	AAT51789	RES, Carbon 10K OHM 1/4W ±5%
R4	AAT51805	RES, Carbon 47K OHM 1/4W ±5%
R5	AAT51813	RES, Carbon 100K OHM 1/4W ±5%
R6	AAT51820	RES, Carbon 200K OHM 1/4W ±5%
R7	AAT51827	RES, Carbon 390K OHM 1/4W ±5%
R8	AAT51835	RES, Carbon 820 OHM 1/4W ±5%
VR	AAT55076	Variable Resistor WJ13T2K
RB	ATT55036	Resistor Block, 1K OHM 8 Elements
	AA062636	Jumper Wire 10

CPU PC BOARD LAYOUT

FIGURE 9

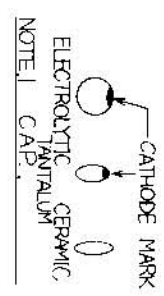
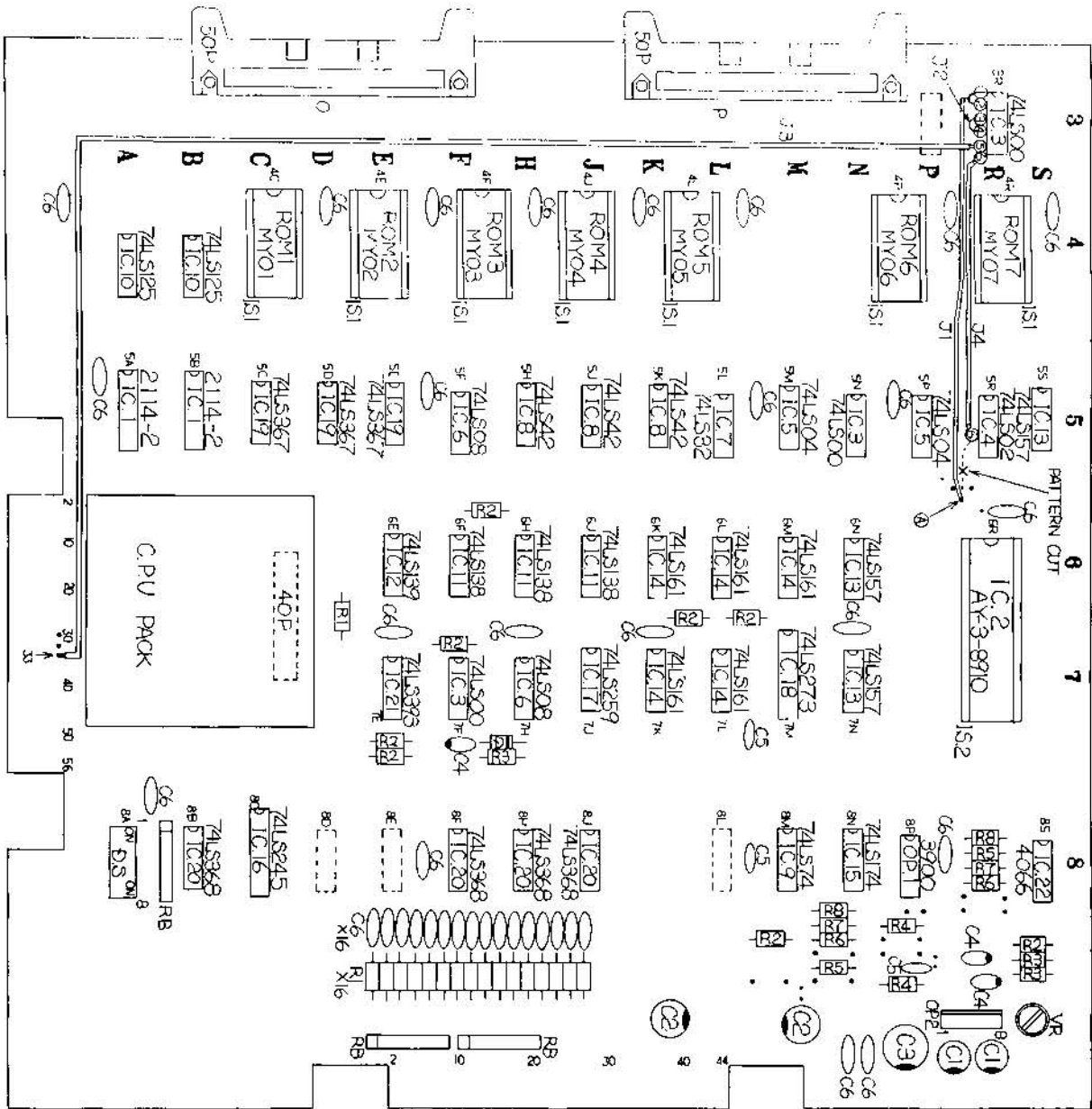

NOTE 2 DIODE & RESISTOR BLOCK

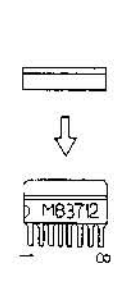

NOTE 3 MB3712

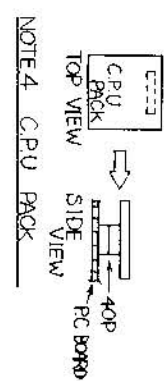

NOTE 4 CPU PACK

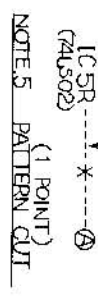

NOTE 5 PATTERN CUT

J No.	WIRING
J1	3R0
J2	3R0
J3	3R0
J4	3R0

NOTE 6 JUMPER(4 POINT)

PC GAME BOARD

FIGURE 10

SYM	TAITO PART NO.	DESCRIPTION
50P	AA055154	Angle Pin Header PS-50PA
6P	AA055230	H-Post Header B6P-SHF-1
IS1	AA055786	IC Socket, 16P
IS2	AA055787	IC-Socket, 24P
X-TAL	AA069590	X-TAL, 18 423MHz ± 0.001
IC1	AAT32131	Static Ram, 2101
IC2	AAT32156	Static Ram, 2114-4
IC3	AAT32183	Static Ram, MB8147
IC4	AAT33001	LS, IC, 74LS00
IC5	AAT33003	LS, IC, 74LS02
IC6	AAT33005	LS, IC, 74LS04
IC7	AAT33009	LS, IC, 74LS08
IC8	AAT33001	LS, IC, 74LS10
IC9	AAT33019	LS, IC, 74LS20
IC10	AAT33026	LS, IC, 74LS26
IC11	AAT33027	LS, IC, 74LS27
IC12	AAT33051	LS, IC, 74LS74
IC13	AAT33062	LS, IC, 74LS86
IC14	AAT33076	LS, IC, 74LS107
IC15	AAT33097	LS, IC, 74LS139
IC16	AAT33112	LS, IC, 74LS157
IC17	AAT33116	LS, IC, 74LS161
IC18	AAT33118	LS, IC, 74LS163
IC19	AAT33119	LS, IC, 74LS164

SYM	TAITO PART NO.	DESCRIPTION
IC20	AAT33127	LS, IC, 74LS174
IC21	AAT33144	LS, IC, 74LS194
IC22	AAT33157	LS, IC, 74LS245
IC23	AAT33170	LS, IC, 74LS273
IC24	AAT33176	LS, IC, 74LS283
IC25	AAT33202	LS, IC, 74LS366
IC26	AAT33203	LS, IC, 74LS367
IC27	AAT33204	LS, IC, 74LS368
IC28	AAT33211	LS, IC, 74LS377
ROM1	M000171	P-ROM (2732) MY08
ROM2	M000172	P-ROM (2732) MY09
ROM3	M000173	P-ROM (2732) MY10
ROM4	M000174	P-ROM (2732) MY11
ROM5	M000175	P-ROM (2732) MY12
C1	AAT41318	Cap, Ceramic 100pf, 50V
C2	AAT41709	Cap, Ceramic 0.001uf, 12V
C3	AAT41713	Cap, Ceramic 0.1uf, 25V
R1	AAT51741	Res, Carbon, 1000hm, 1/4W $\pm 5\%$
R2	AAT51745	Res, Carbon, 1500hm, 1/4W $\pm 5\%$
R3	AAT51749	Res, Carbon, 2200hm, 1/4W $\pm 5\%$
R4	AAT51753	Res, Carbon, 3300hm, 1/4W $\pm 5\%$
R5	AAT51757	Res, Carbon, 4700hm, 1/4W $\pm 5\%$
R6	AAT51765	Res, Carbon, 1K Ohm, 1/4W $\pm 5\%$

PC GAME BOARD

FIGURE 10

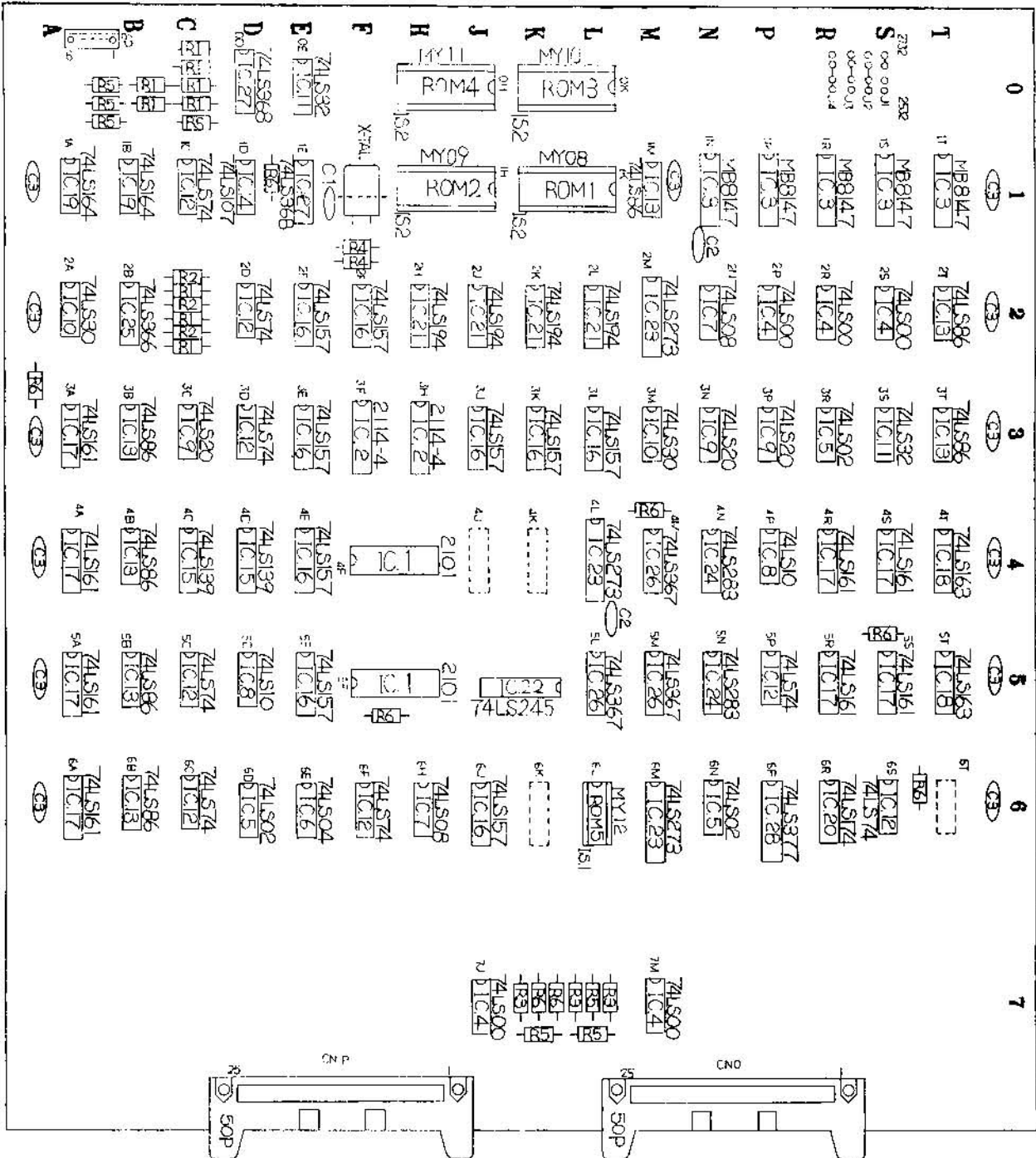

WIRING DIAGRAM

FIGURE 11

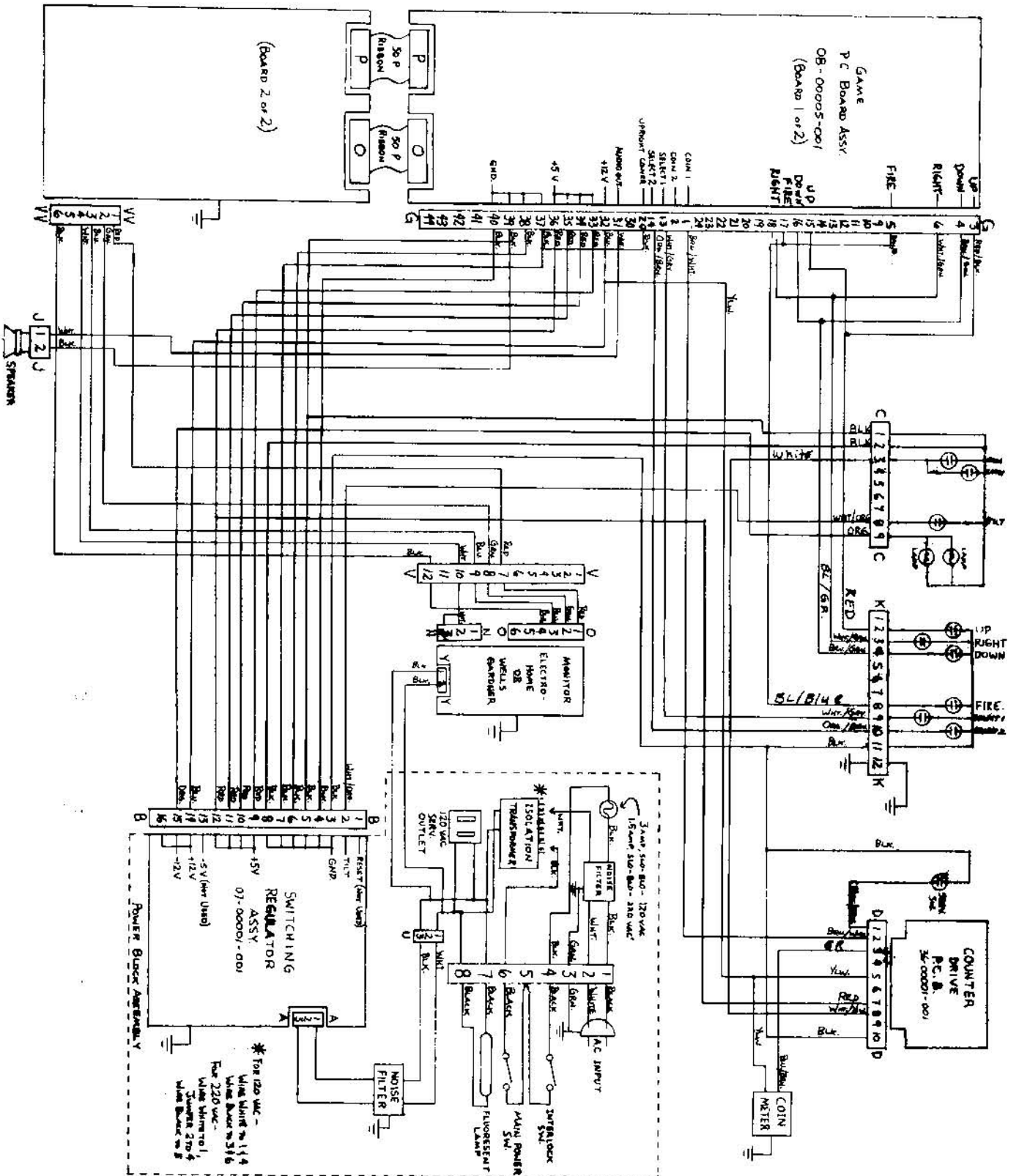

CPU BOARD "B" SCHEMATIC

FIGURE 13

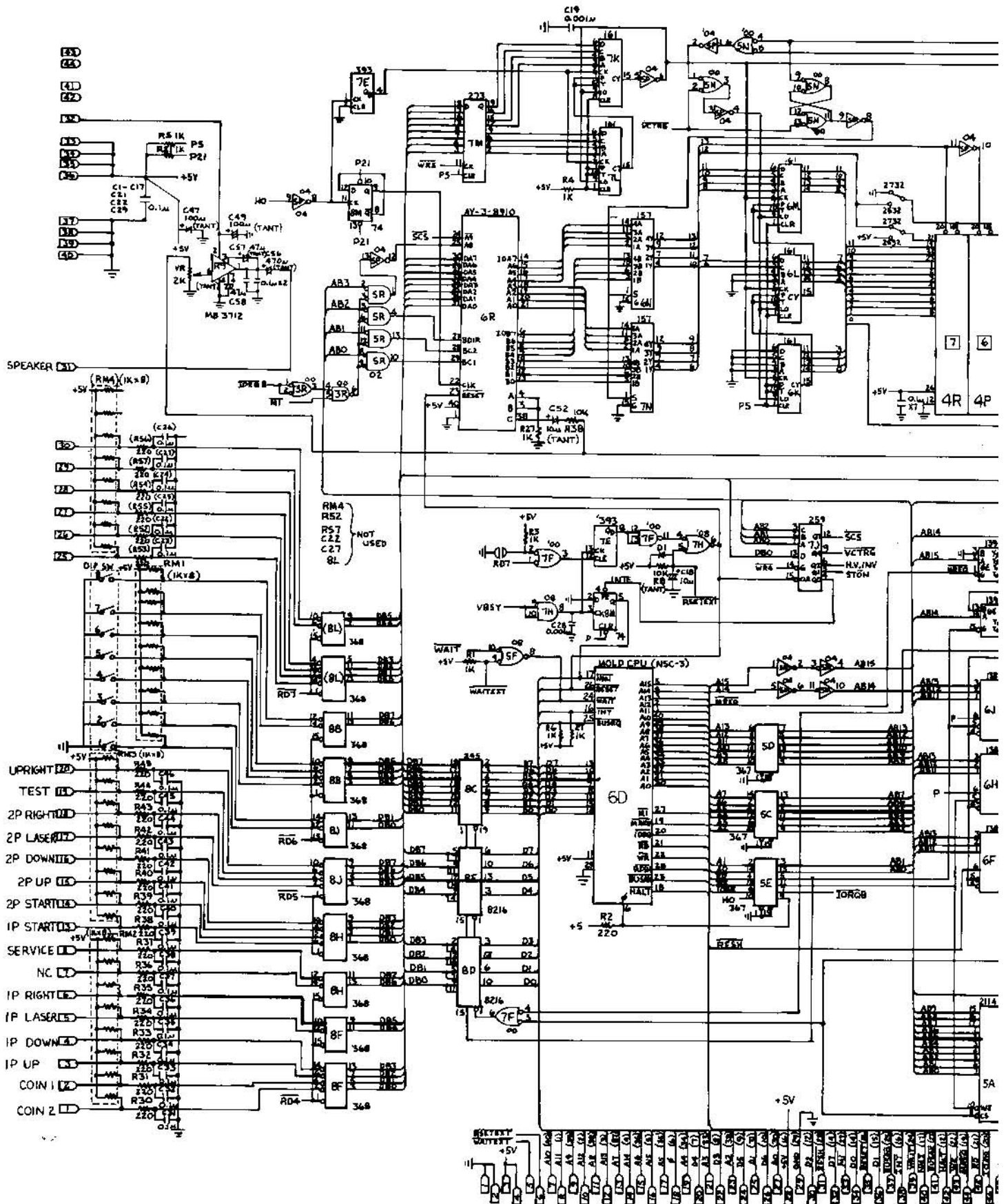

B" SCHEMATIC FOLD-OUT

FIGURE 13

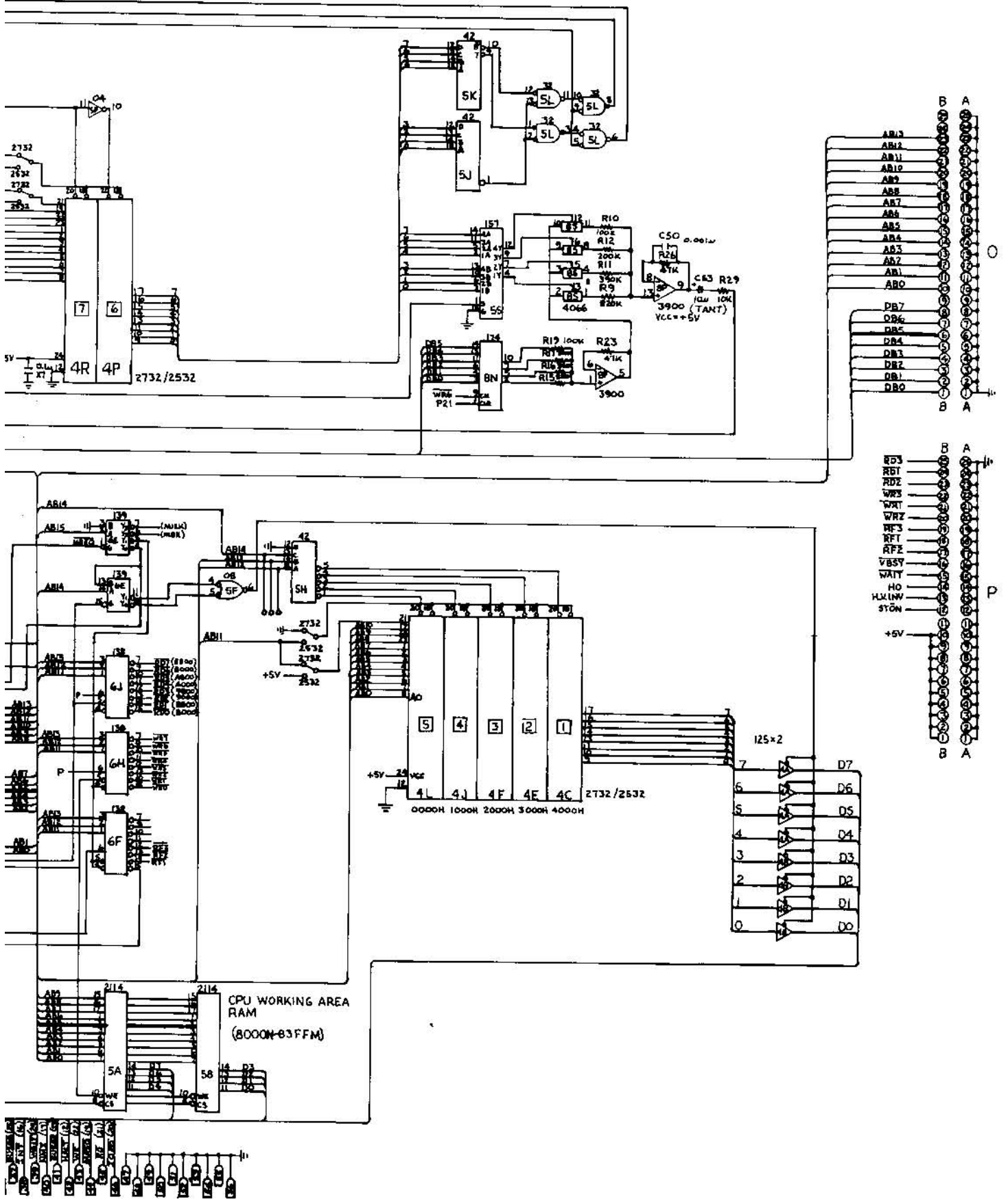

GAME BOARD "A" SCHEMATIC

FIGURE 12

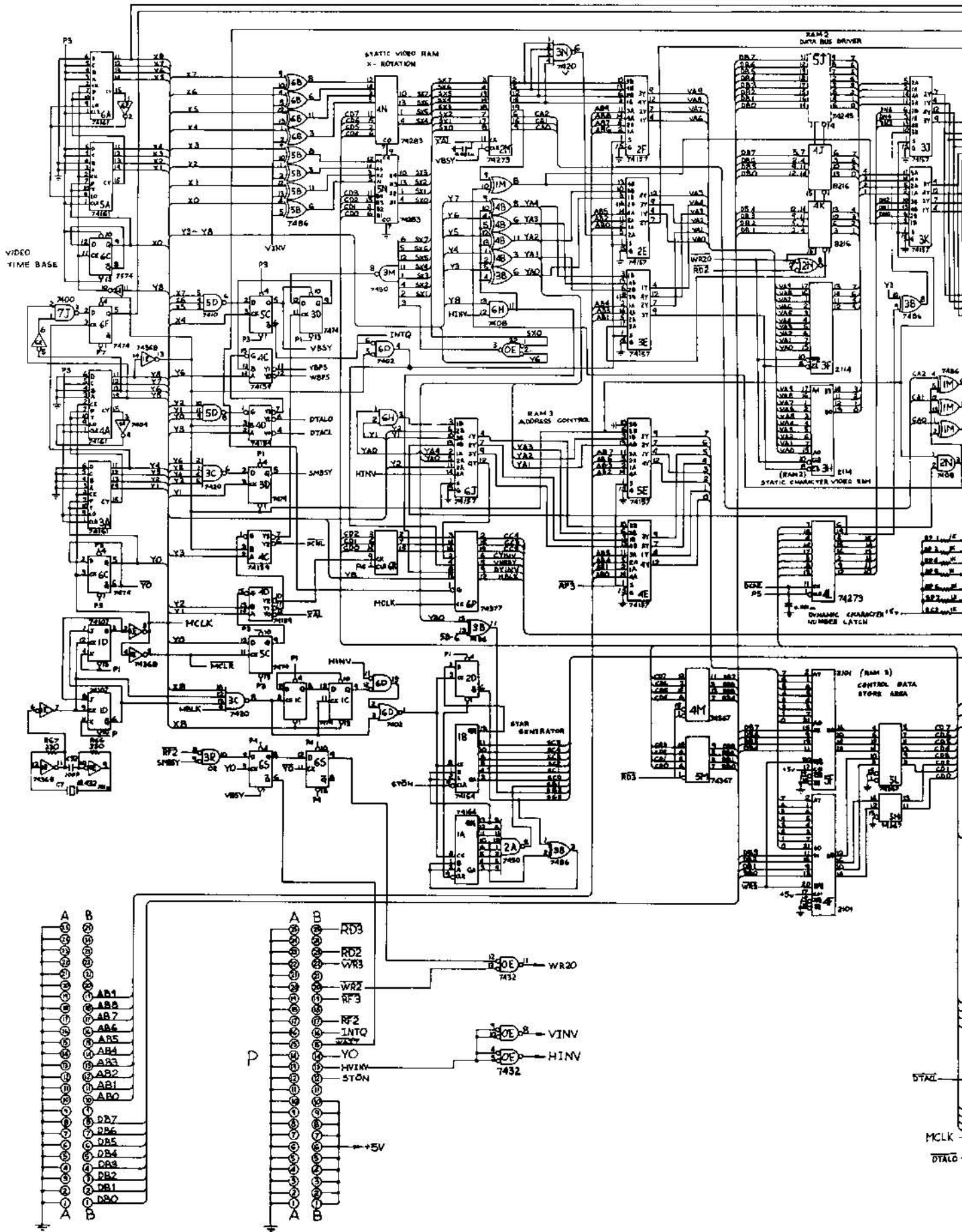

IRD "A" SCHEMATIC FOLD-OUT

FIGURE 12

