

Nintendo-Pak™



NINTENDO-PAK™ INSTALLATION & OPERATION MANUAL

FOR

**DONKEY KONG
JUNIOR**

DONKEY KONG

POPEYE*

Nintendo®



WARNING

This instruction manual is for use only by authorized distributors of Nintendo of America Inc., coin operated video arcade games who have been licensed to install replacement parts and components in Nintendo arcade games pursuant to Nintendo-Pak™ license agreements.

WARNING

If the replacement parts and components in this Nintendo-Pak™ are not installed exactly as instructed herein, there may be radio frequency interference created in violation of F.C.C. class A standards.

WARNING

This equipment generates, uses, and can radiate radio frequency energy, and if not installed and used in accordance with the instruction manual, may cause interference to radio communications. It has been tested and found to comply with the limits for a class A computing device pursuant to subpart J of part 15 of F.C.C. rules, which are designed to provide reasonable protection against such interference when operated in a commercial environment. Operation of this equipment in a residential area is likely to cause interference; in which case, the user at his own expense will be required to take whatever measures may be required to correct the interference.

WARNING

Use of non-Nintendo parts or modifications to your Nintendo-Pak™ parts and components may adversely affect the safety of your game, and may cause injury to your players.

TABLE OF CONTENTS

I. Introduction	3
II. Contents of Nintendo-Pak™	4-5
III. List of Tools Needed	6
IV. Replacement Process Step-by-Step	7-20
V. Final Check Sheet and Adjustments	21-28
VI. Mario Bros. Wiring Diagram	29-31
VII. Service Bulletins	32-35
VIII. CPU P.C., VIDEO P.C., and Power Supply Schematics	36-38
IX. Reorder Parts Lists	39-47

I. INTRODUCTION

Nintendo-Pak™

Nintendo-Pak™ enables you to replace Donkey Kong*, Donkey Kong Jr.* or Popeye** with Mario Bros.* in less than one hour.

Before you begin, be sure you are properly prepared. Make certain you have selected the right **Nintendo-Pak*** for the particular game you are replacing. Next, thoroughly read this instruction manual to familiarize yourself with the proper procedures. Make certain that you have all the tools necessary to complete the process.

If you have any questions, please call Nintendo Service at 1-(800)-633-3236.

* Donkey Kong, Donkey Kong Jr., Mario Bros. and Nintendo-Pak are trademarks of Nintendo of America Inc.

** A trademark of King Features Syndicate, Inc.

II. Contents of Nintendo-Pak

Parts Name	Quantity	Remarks
Pak (A) Basic Pak		
Mario Bros. Complete P.C. Board Set	1	
C-TMA-US Complete Operation Panel Assembly	1	with harness
Mario Bros. Plate 600W	1	
Mario Bros. Screen 600W	1	
Mario Bros. Side Decal	2	
Nintendo-Pak™ Manual	1	
Pak (B) Donkey Kong and Donkey Kong Jr.		
FCC Shield Cage	1	
044 Shield Cage Cover Complete Assembly	1	with FCC Harness
Monitor Mounting Bracket (Right)	1	
Monitor Mounting Bracket (Left)	1	
Monitor Support Bar	2	
Black Cardboard Bezel	1	with double back tape
C-UP44P-044 Edge Connecting Main Harness	1	
Ground Cable E	1	
Serial Number Plate	1	
TMAI-UP Back Door Adjustment Label	1	with double back tape
FCC Class A Label	1	
Sticker Tie Down	2	
Cable Tie	2	
Carriage Bolt M6 x 30	6	
Hex Nut with Washer M6	6	
Hex Nut M6	6	
Hex Nut with Washer M5	4	
Machine Screw with Washer M5 x 12	4	
Machine Screw with Washer M4 x 10	6	
Round Head Wood Screw 3.5 x 13	10	

II. Contents of Nintendo-Pak (Cont'd.)

Parts Name	Quantity	Remarks
Pak (C) Popeye		
821B-7B Power Assembly	1	TKGU-18-01 DJRU-19-01
044 FCC P.C. Board Assembly	1	
44P 044 FCC P.C. Board Harness	1	
Serial Number Plate	1	
TMAI-UP Back Door Adjustment Label	1	with double back tape TMA-41-16, DJR-89-09, DJR-89-08
UP44P-044 Edge Connecting Main Harness Assembly	1	
Fuse 4A 125V	1	
Fuse 5A 125V	2	
Cable Tie	2	
5A Fuse Label	1	

III. List of Tools Needed

Flat (standard) screwdriver

Phillips screwdriver

7mm nut driver

8mm nut driver

10mm nut driver

¼" or 6.5mm drill bit

Electric reversing drill

Phillips bit (for drill)

Staple gun

Paper stapler

Lacquer thinner

Denatured alcohol or other cleaner

Note: Many steps require the use of a phillips screwdriver and having a phillips screwdriver bit for your drill will greatly speed up these steps.

IV. Step-by-step instructions

1. Exchange marquee/header (see illustration 1-1)
 - A. Remove four (4) top trim screws
 - B. Exchange marquee plexiglass
 - C. Replace top trim and four (4) top trim screws

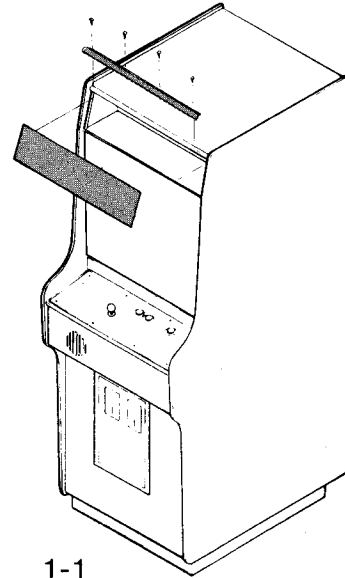

1-1

2. Remove old control panel and front screen (see illustration 1-2)
 - A. Undo control panel holddown clamps
 - B. Disconnect harness and remove control panel
 - C. Remove front screen by sliding back front screen clamp (access from back door)

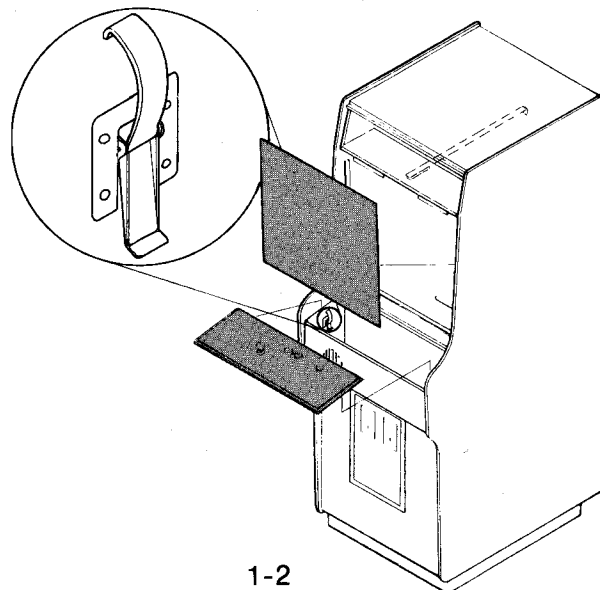

1-2

Steps 3-5 for Donkey Kong and Donkey Kong Jr. ONLY

Note: If replacing Popeye, proceed to Step 6

3. Remove instruction label (see illustration 1-3)
Note: For Donkey Kong, Donkey Kong Jr. ONLY

- A. Spray label with lacquer thinner
- B. Wait 15 minutes and remove with putty knife
- C. Clean area with cloth and lacquer thinner

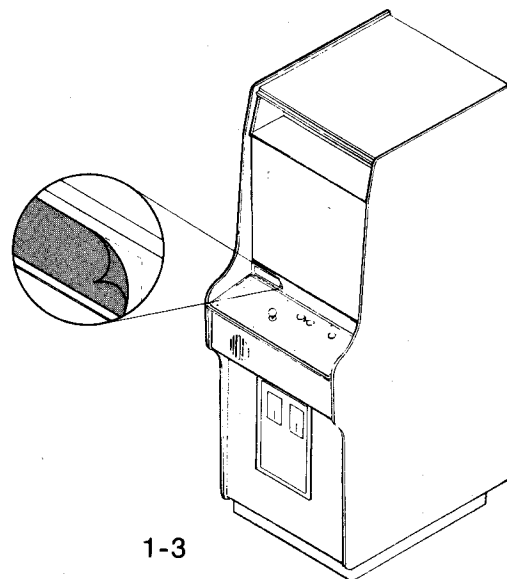

4. Remove monitor

- A. Unplug monitor connections and undo wire ties
- B. Remove blind cardboard on monitor only
- C. Remove monitor, upper monitor support bar and all carriage bolts (see illustration 1-4)
- D. Remove old side decal
- E. **IMPORTANT! Disconnect monitor ground wire at location shown in illustration** (see illustration 1-5)

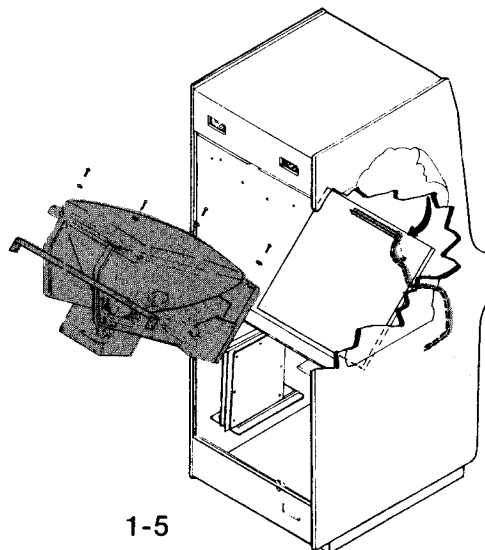
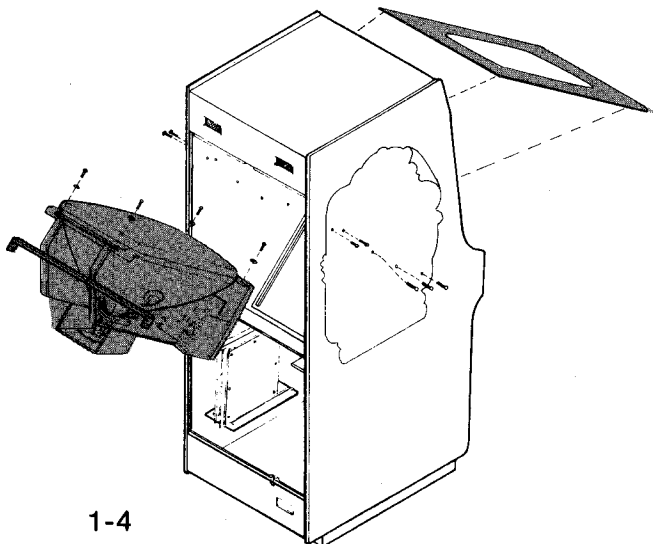

These steps are for Donkey Kong and Donkey Kong Jr. ONLY

- F. Side panels should have five (5) holes each. If your game has only two (2) holes, use template provided in kit and drill three (3) 1/4-inch or (3) 6.5-mm holes where indicated. (see illustration 1-6)

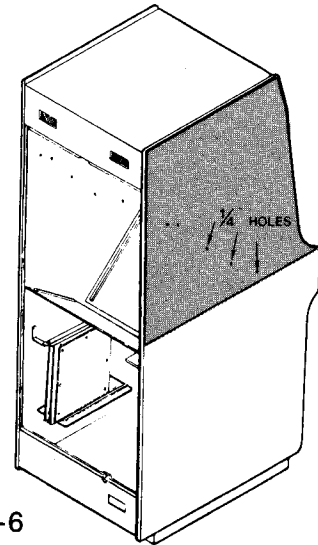

1-6

- G. Clean side panel with alcohol and install new Mario Bros. side decal. Note: Decal is placed parallel to top and back of game 2" from edge. (see illustration 1-7)

See decal application sheet on page 20

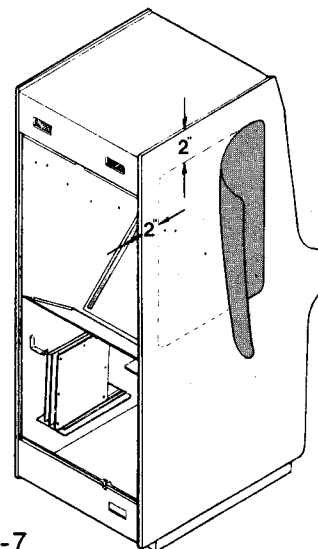

1-7

These steps are for Donkey Kong and Donkey Kong Jr. ONLY

H. Install side support bars on monitor (see illustration 1-8)

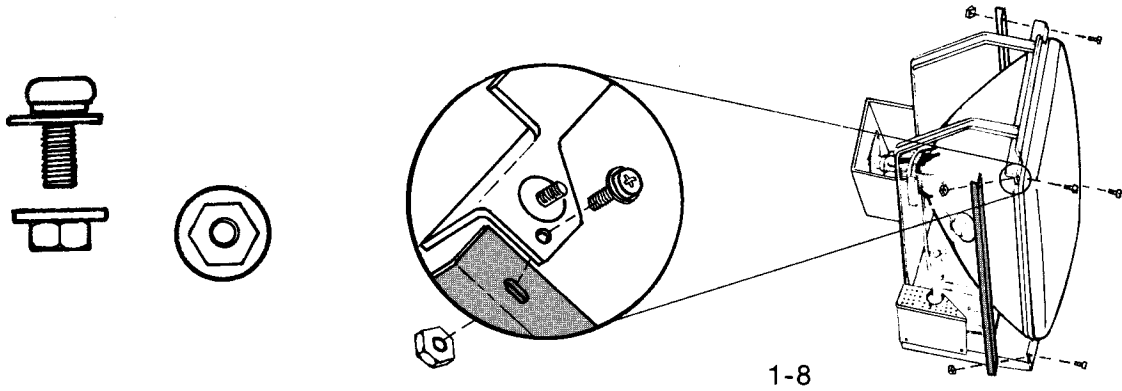

- I. Install new horizontal monitor mounting brackets to side panel with flange toward front of cabinet and pointing up. Note: use two (2) nuts on carriage bolt as shown (see illustration 1-9 & 1-10)
- J. Install monitor in horizontal position
- K. Monitor is placed on top of side bracket supports
- L. **IMPORTANT! Reconnect the monitor ground wire (disconnected in step 4E) carriage bolt shown.** (see illustration 1-10)

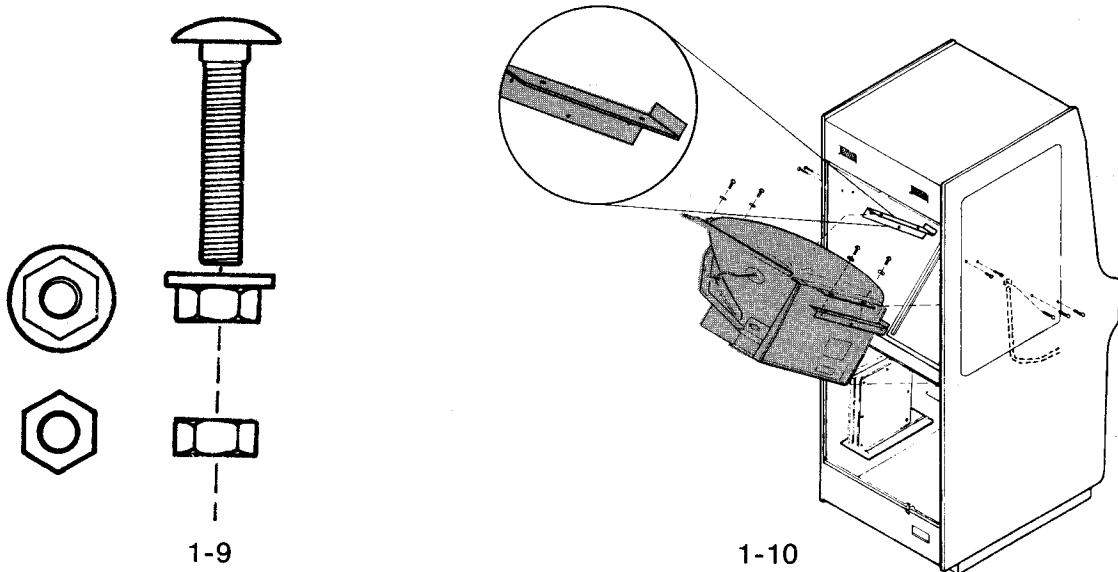

These steps are for Donkey Kong and Donkey Kong Jr. ONLY

- M. Install new blind cardboard (see illustration 1-11)
- N. Once blind cardboard is in place, staple together slot with regular paper stapler (see illustration 1-12)

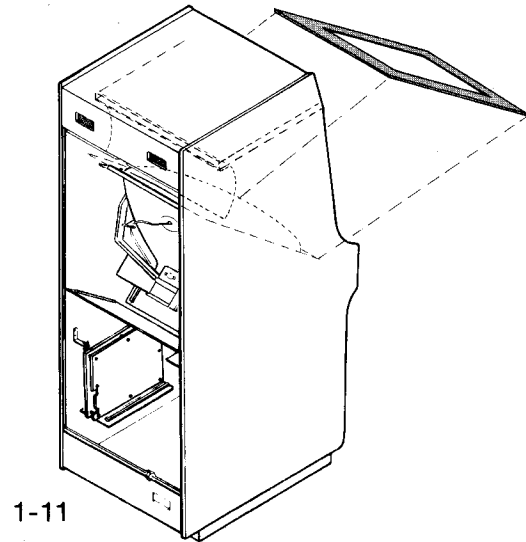
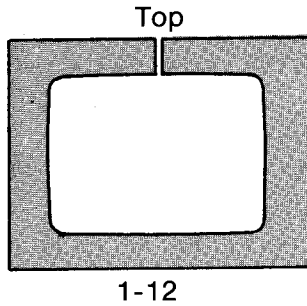

5. Installation of FCC shield cage (see illustration 1-13)

- A. Unscrew wing nuts and remove P.C. Board assemble and all wire harnesses **EXCEPT** three (3) harness connections to coin door (2 pin counter, 3 pin coin, 5 pin service)
- B. Remove P.C. Board mounting brackets

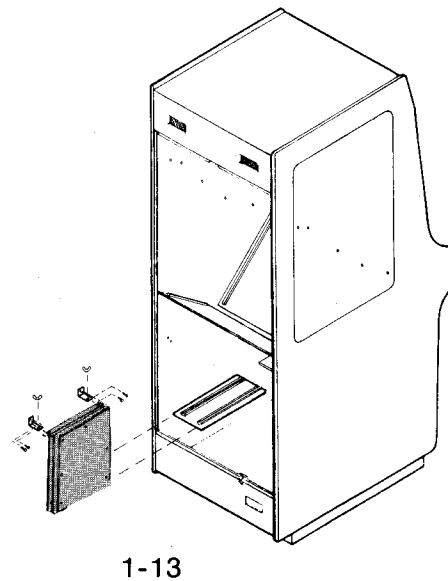

These steps are for Donkey Kong and Donkey Kong Jr. ONLY

- C. If P.C. Board wood shelf has slots made from square stock wood, remove these (see illustration 1-14)

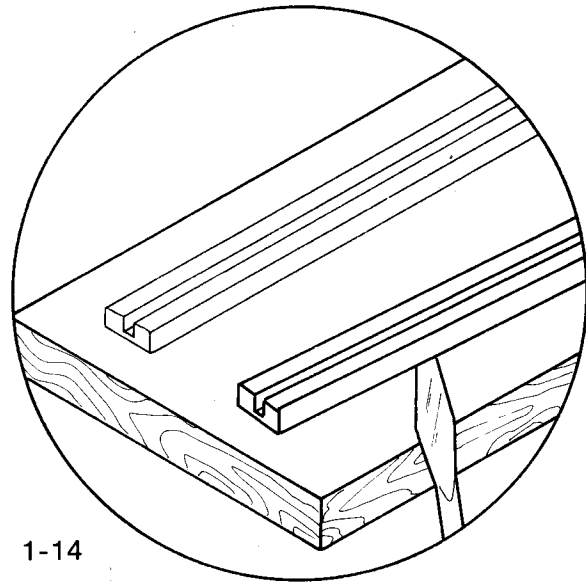

- D. Install new FCC shield cage so it is flush with rear of wood shelf and fasten with six (6) screws provided. **IMPORTANT! On lower left corner install ground harness and connect the other end to the mounting bolt on the power supply as shown.** (see illustration 1-15 & 1-16)

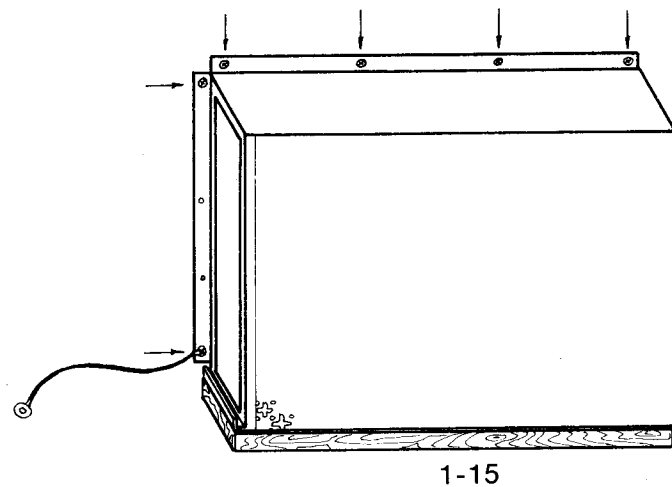
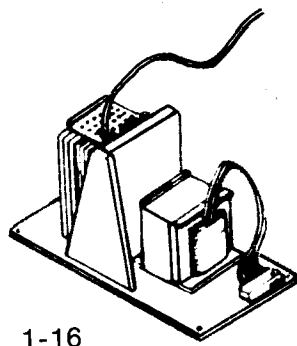

Steps 6-9 for Popeye ONLY

Note: If replacing Donkey Kong or Donkey Kong Jr., proceed to Step 10

6. Replacement of side decals for Popeye (see illustration 2-1)

- A. Unplug monitor connections and remove monitor
- B. Remove all carriage bolts and monitor side panel supports
- C. Remove old stickers and clean side panels with alcohol

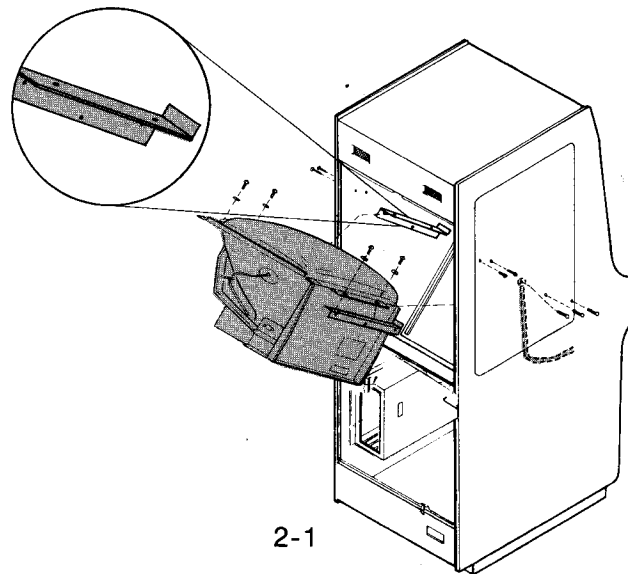

- D. Put on new side decals
Note: Decal is placed parallel to top and back of game 2" from edge (see illustration 2-2)
SEE DECAL APPLICATION SHEET ON PAGE 20

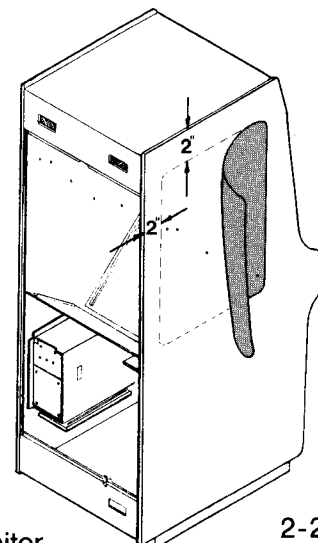

- E. Replace all carriage bolts, side monitor supports and monitor (see illustration 2-1)
- F. **IMPORTANT! Be sure to reconnect the monitor ground**

These steps are for Popeye ONLY

7. If you are replacing a Popeye game, remove old power supply transformer assembly (see illustration 2-3 & 2-4)

- A. Disconnect connector from switch plate
- B. Disconnect both plugs for monitor and lamp
- C. Disconnect ground harness connections
- D. Disconnect both power harness connections
- E. Remove four (4) wing nuts and take out old power supply
- F. Replace with new Mario Bros. power supply assembly and tighten wing nuts
Note: Bolts for wing nuts may push through bottom of game during mounting of new power supply unit. If this happens, simply push them back up when power supply assembly is in place.
- G. **Reconnect Steps A, B, & C being careful to get a good connection on Step C. Ground harnesses.**

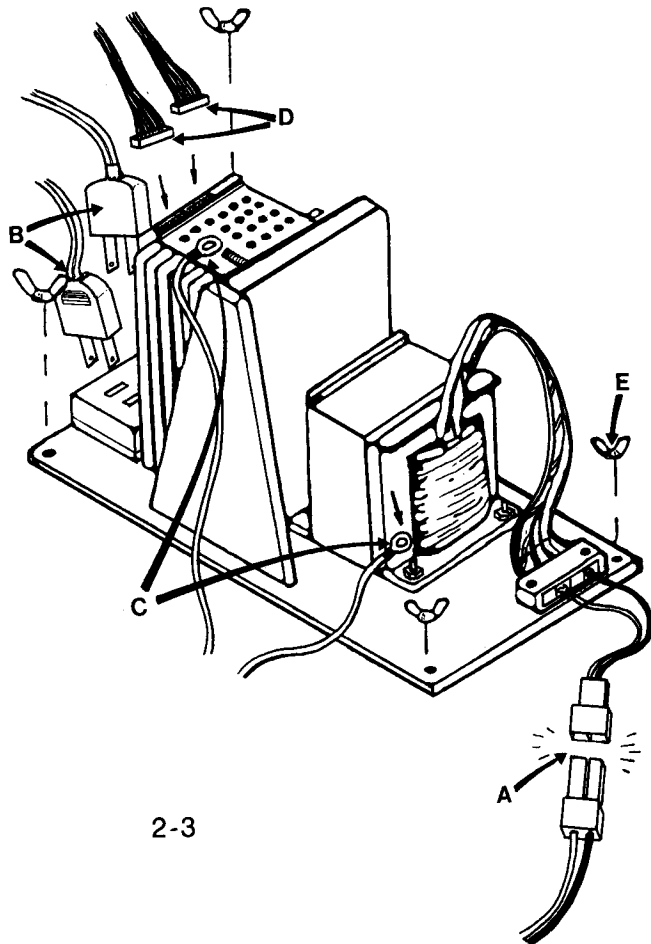
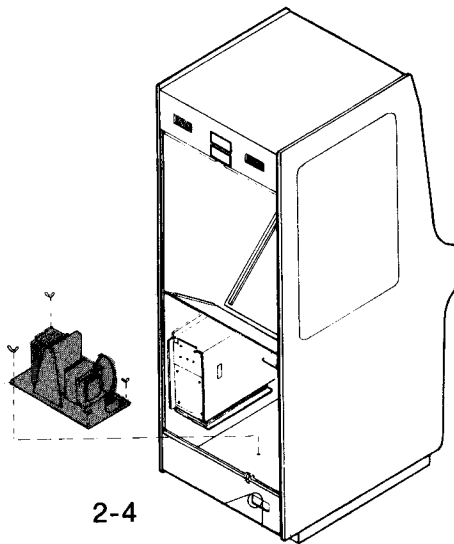

These steps are for Popeye ONLY

8. Change fuse to 5 AMP and change label to 5 AMP on switch plate (see illustration 2-5)

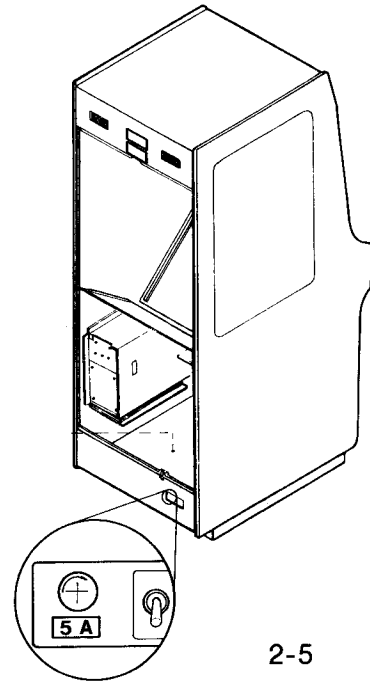

2-5

9. Remove old P.C. Board assembly (see illustration 2-6)
- A. Remove the six (6) machine screws that hold on the FCC cage cover
 - B. Remove the FCC cover and disconnect both edge connectors
 - C. Remove the FCC P.C. Board from the FCC cage cover
 - D. Install new Mario Bros. FCC P.C. Board on cage cover

Note: Check to make sure new FCC Board is part 044-01-FCC

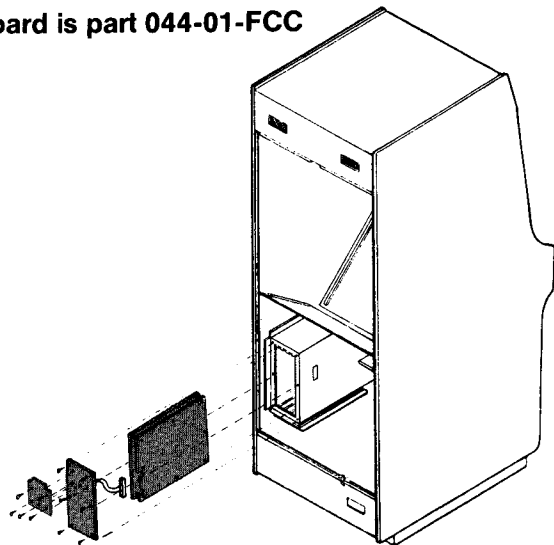

2-6

These steps are for Popeye, Donkey Kong and Donkey Kong Jr.

10. Install Mario Bros. boards (see illustration 3-1)
 - A. Insert new short-wire harness between FCC P.C. Board and Mario Bros. P.C. Board. Note: Do not screw on cover until final check sheet and adjustments (Section V) is complete.

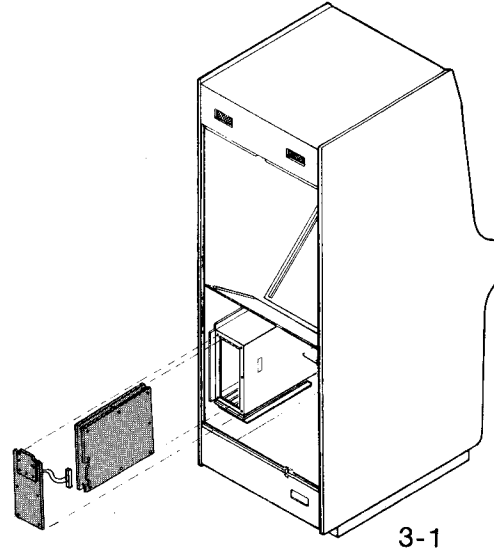

11. For step 11 see opposite page
12. Connect new Mario Bros. control panel to main harness and fasten down control panel (see illustration 3-3)
13. Install new Mario Bros. front screen and fasten with front screen clamp
 - A. **IMPORTANT! Place authorized Mario Bros. sticker on front screen in location shown** (see illustration 3-3)

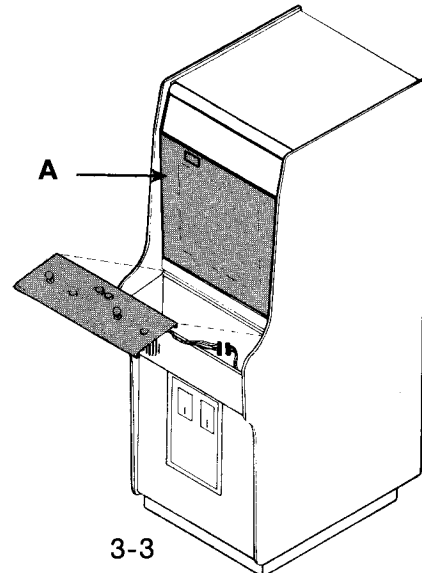

This step is for Popeye, Donkey Kong and Donkey Kong Jr.

11. Connect main harness assembly (see illustration 3-2)
 - A. Connect 2 pin, 3 pin, 4 pin coin door harnesses to main harness
(Note: Harnesses are different for Popeye, Donkey Kong, and Donkey Kong Jr.)
 - B. Fasten control panel connectors to wire tie approximately 5" from connectors
 - C. Route the main harness through existing wire ties and then install two (2) new stick-on ties to FCC shield cage to hold harness securely
 - D. Connect 4 pin sound and 6 pin video from monitor to main harness
 - E. Connect 9 pin and 10 pin power supply connectors
 - F. Fasten power supply harness to FCC shield cage with cable ties.

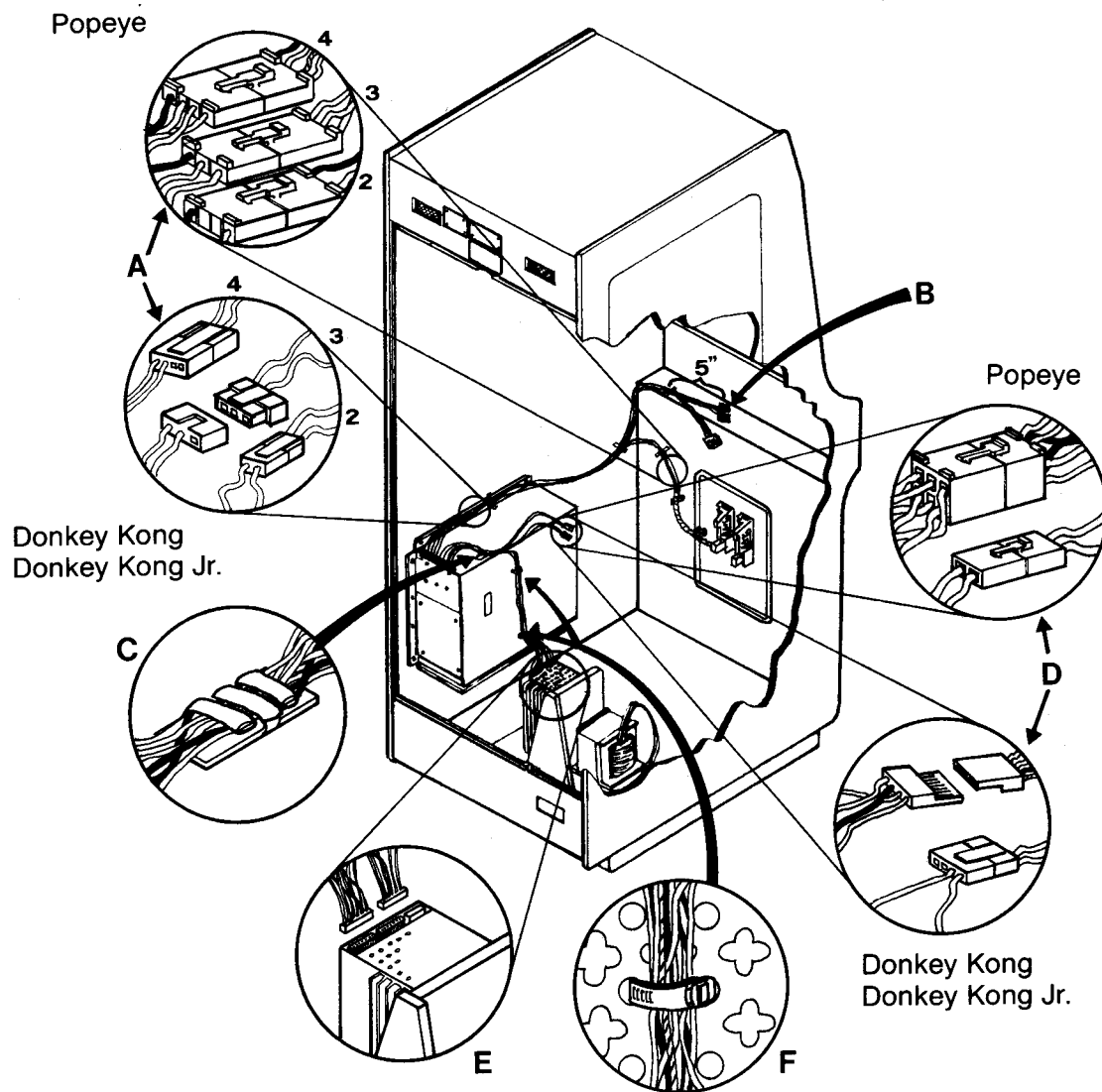

3-2

14. Screw on new serial number plate next to old plate.
IMPORTANT! Do not remove old plate
(see illustration 3-4)

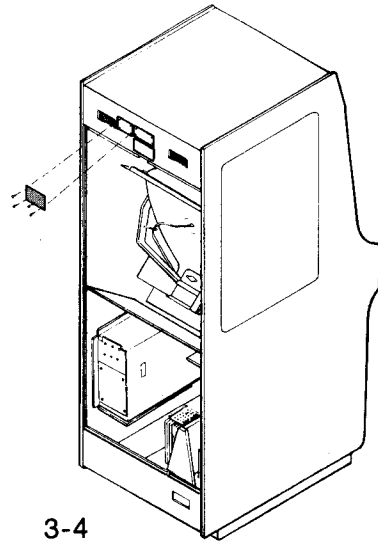

15. Attach FCC Class A label (see illustration 3-5)
- A. Remove old FCC label
 - B. Put on new FCC label and staple all four corners

Not necessary for POPEYE

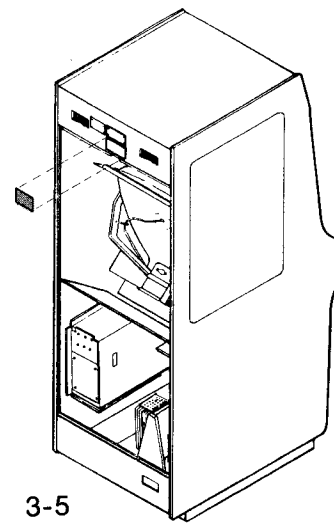

16. Attach FBI sticker

- A. Place label on back door just under lock (see illustration 3-6)

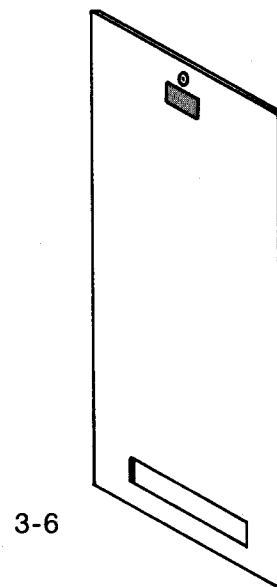

17. Attach new back door adjustment label

- A. Peel off old label and replace with new Mario Bros. label. Staple all four corners. (see illustration 3-7)

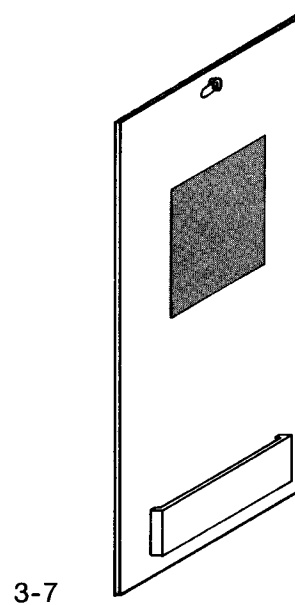

Side Decal Application

Step 1.

Start by peeling the protective backing "A" down about 6 inches from the top.

Place decal in desired position. Pull down slowly the remainder of the protective backing of "A."

While doing this, use a soft cloth to smooth decal onto side board, moving from top to bottom of decal.

Step 2.

Fold remaining decal back, exposing the unprinted side. Begin to peel protective backing "B" from center to right hand side "slowly."

Using soft cloth smooth decal onto side panel by running hand from top to bottom of decal, moving outward to the right hand side.

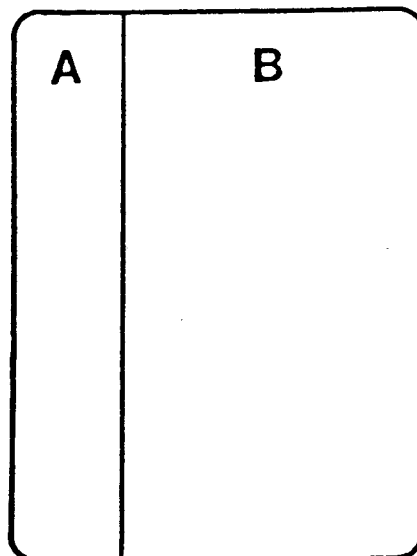

Front View

V. FINAL CHECK SHEET AND ADJUSTMENTS

- 1. Replacement label installed (MANDATORY)
- 2. FBI sticker installed (MANDATORY)
- 3. New serial number plate installed (MANDATORY)
- 4. New FCC label installed (MANDATORY)
- 5. New adjustment label installed
- 6. Fuse label changed (Popeye only)
- 7. P.C. Board adjustments made
(see PC Board adjustments page 22)
- 8. Monitor adjustments made
(see monitor adjustments pages 23-24)
- 9. Self-test check (see pages 26-27)
- 10. Coins give credit
- 11. Controls on operation panel functioning
- 12. Sound checked

Adjustments

After powering up the game, you will probably find that the screen's horizontal width is too narrow and the vertical height is too small. To make adjustment to the horizontal width, refer to the illustration on page 00. To adjust the vertical height, use the V-size adjustment on the rear of the monitor to make the picture larger.

Also, it may be necessary to adjust the vertical and horizontal position controls on the video p.c. board as shown below to center the picture.

P.C. Board Adjustments



Adjustment of Semi-Fixed Resistors

VIDEO P.C. Board

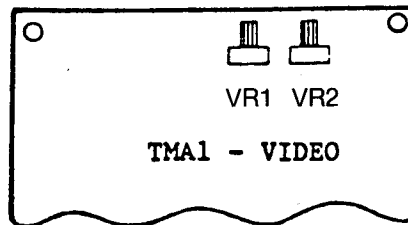
Semi-fixed resistors, VR1 and VR2 on VIDEO P.C. Board are used to adjust video monitor screen.



VIDEO P.C. Board

VR1	50K Ω 1/3W white knob	V - pos		move clockwise to move picture up
VR2	50K Ω 1/3W white knob	H - pos		move clockwise to move picture left

Adjustment of Horizontal Width

Caution! High Voltage Area — BE CAREFUL!

Using a standard 2.6mm hex non-conductive core alignment driver, carefully turn L453 counter-clockwise for a smaller horizontal screen size. L453 is located in the rear of the monitor just under the deflection yoke.

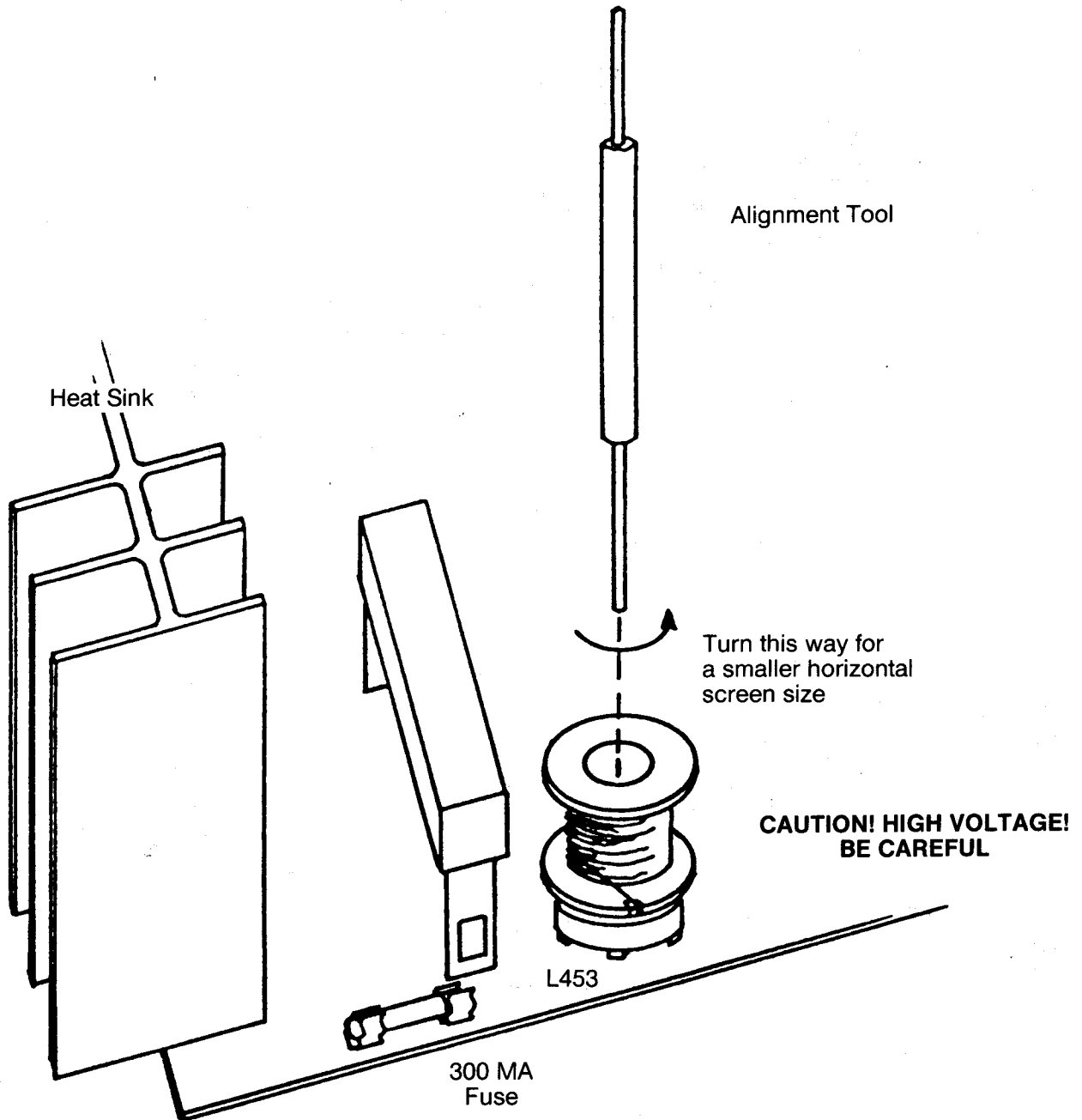

Adjustment of Video Monitor

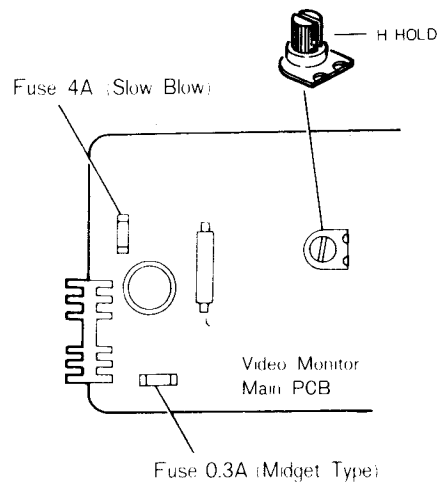
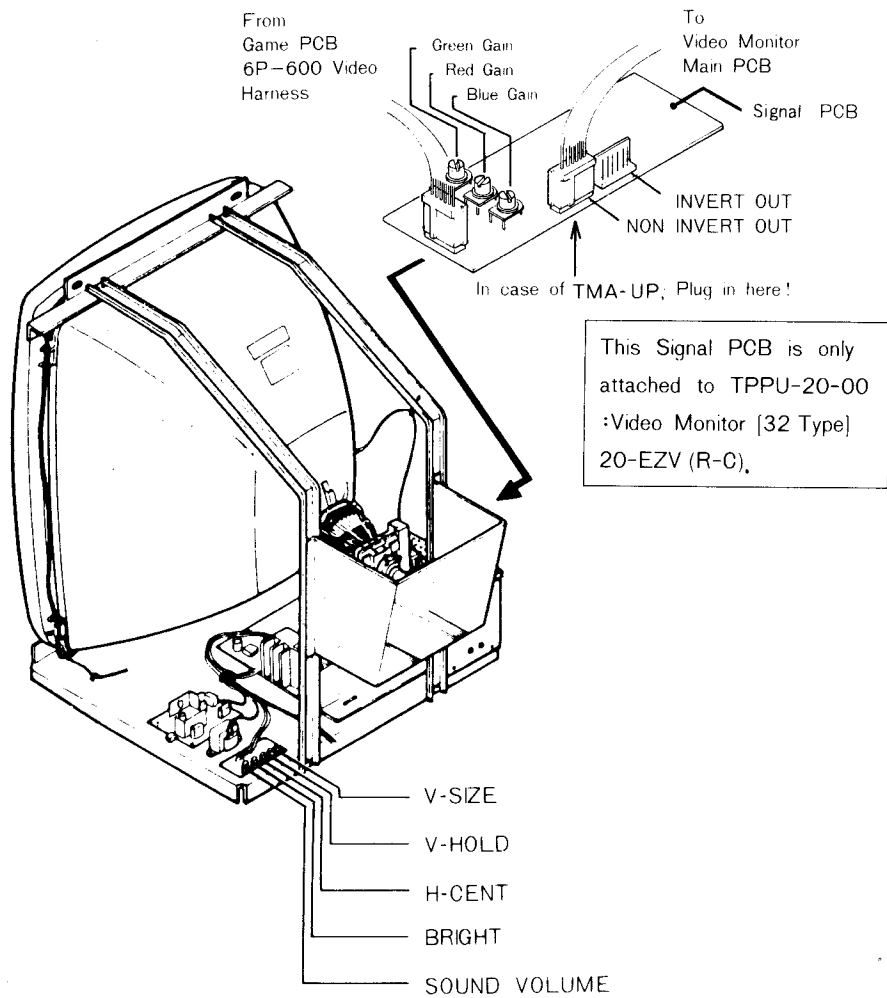

Video Monitor

WARNING

Do not touch the inside of the Video Monitor.
It contains many parts supplied with high voltage.

Option Switch Settings

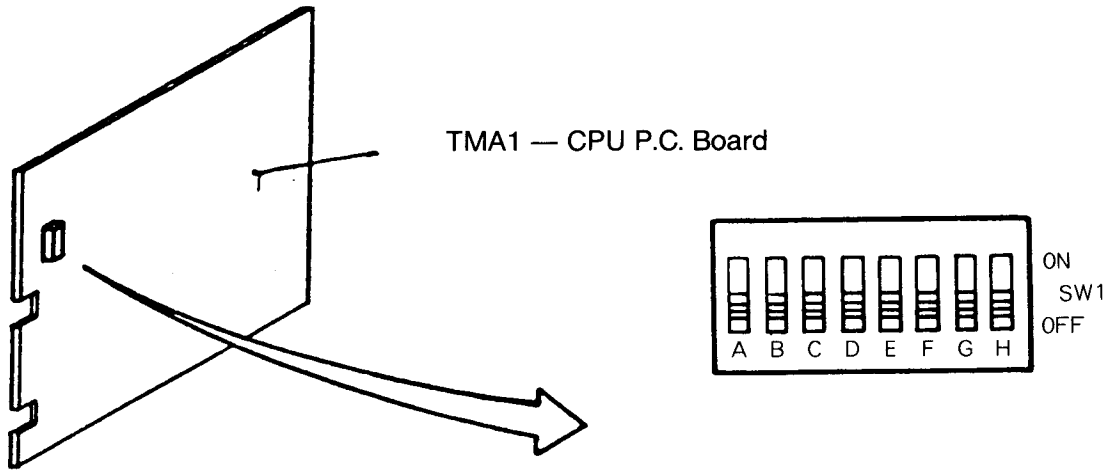

		TOGGLE (SW) SETTINGS							
		A	B	C	D	E	F	G	H
NUMBER OF	3	OFF	OFF						
MARIO/LUIGI	4	ON	OFF						
PER GAME	5	OFF	ON						
	6	ON	ON						
COIN/CREDIT	2/1			ON	OFF				
	1/1			OFF	OFF				
	1/2			OFF	ON				
	1/3			ON	ON				
EXTRA	20,000PTS.					OFF	OFF		
MARIO/LUIGI	30,000PTS.					ON	OFF		
AT	40,000PTS.					OFF	ON		
	NO EXTRA					ON	ON		
DIFFICULTY EASY	1							OFF	OFF
	↓ 2							OFF	ON
	↓ 3							ON	OFF
	HARD 4							ON	ON

WARNING
All the Option Switch Settings **MUST** be done with power off.

Bookkeeping and Self-Test

- (1) Entry
Press Service Switch and hold it down until Menu of Test Mode displays on the Video Monitor as follows.

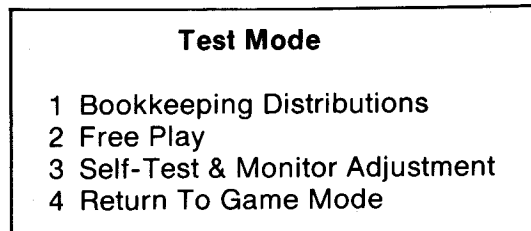

- (2) Selection of Test

A flashing Shellcreeper points to the Test. Momentarily depressing Service Switch will step to next Test. When the shell creeper is pointing to the desired Test, the details of the Test can be displayed by pressing the Service Switch and holding it down until the details appear on the Video Monitor. (Except "Return To Game Mode")

- (3) Back to Menu of Test Mode
You can recall Menu of Test Mode by holding down Service Switch until it re-appears.
- (4) When the shellcreeper is pointing to "Return To Game Mode", you will be able to return to Game Mode (Demonstration Game) by holding down Service Switch until it re-appears.

(WARNING)

Test Mode will go back to Game Mode automatically if you do not push a switch or button or move the controller within a few minutes.

- A. Bookkeeping Distributions:
1. Playtime distributions and number of plays per distribution range.
 2. Score distributions and number of plays per distribution range.
 3. Number of One (1) player games and playtimes per distribution range.
 4. Number of Two (2) player games and playtimes per distribution range.
- * To clear all distributions, press either start button.
 ** Bookkeeping distribution system will not function when game is set in Free Play Mode.

B. Pressing either start button will set or clear "FREE PLAY" mode.

C. Self-Test & Monitor Adjustment
 Pressing either start button will step to the next Test.

C-1 RAM and ROM Test
 The result of RAM and ROM Test will be displayed on the Video Monitor as follows.

Example

RAM ROM TEST			
RAM		ROM	CHECKSUM
7A	OK	7C	OF
7B	OK	7D	"
		7E	"
		7F	"
RAM location on the PCB		ROM location on the PCB	

(OK: Passed)
 (NG: Failed)

C-2 CRT Test
 Color Bar and Marks on four Corners and center of screen are displayed on the Video Monitor one after another.

C-3 Sound Test
 You will hear the various sounds one after another.

C-4 Switch Test
 The result of the switch condition will be displayed on the Video Monitor when you press each of the switches or move the controllers.
 (2-Way Controllers, Jump Switches, 1-Player Switch, 2-Player Switch and Coin Switches.)

C-5 End of Self-Test.

Switch Maintenance

Micro-Switch Replacement

Whenever you replace any micro-switch on the Operation Panel, a switch gap adjustment is needed as shown below.

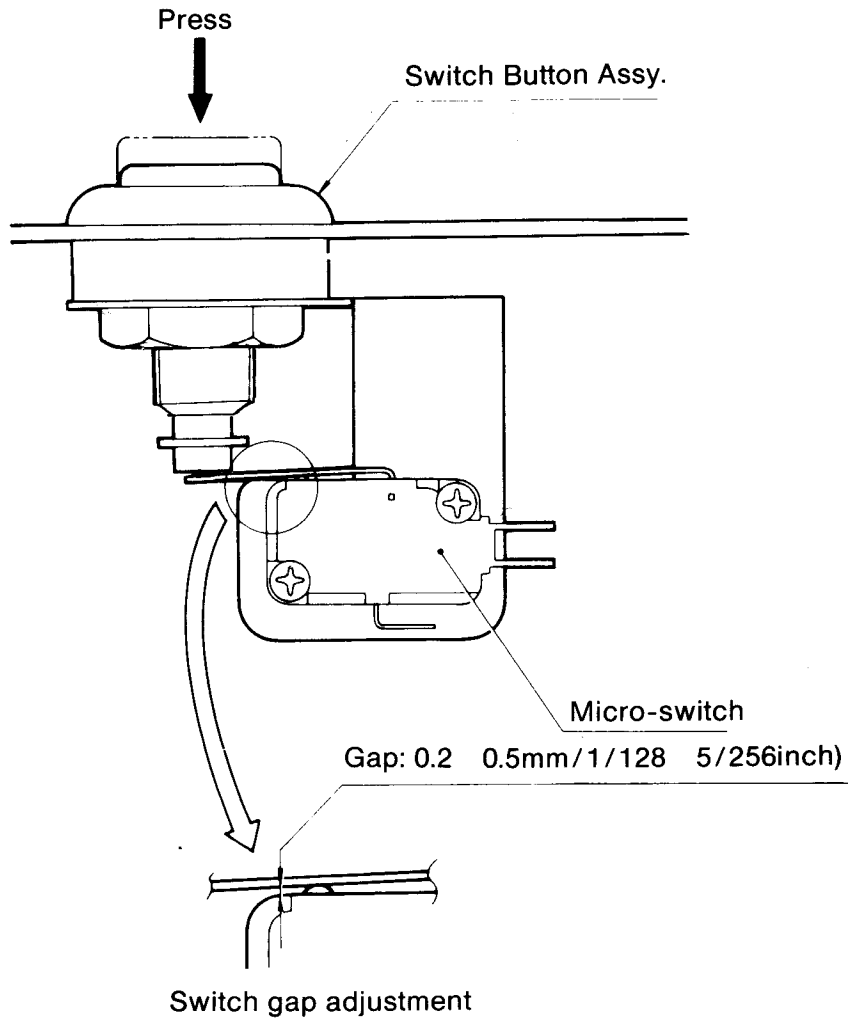

Lubrication for 2 way Controller

To maintain the 2 way Controller in good condition, lubricate the pillow balls and 2 way Guide Plate approx. every 3 months. See Fig. 9.

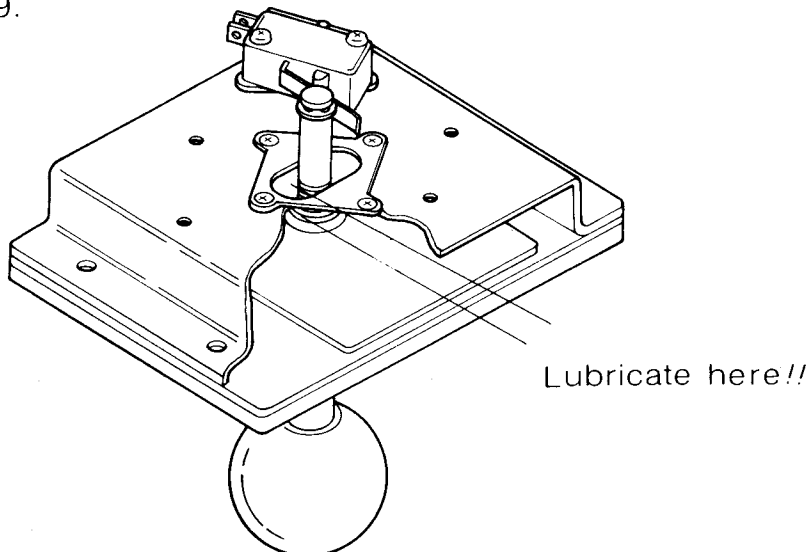

VI. WIRING DIAGRAM

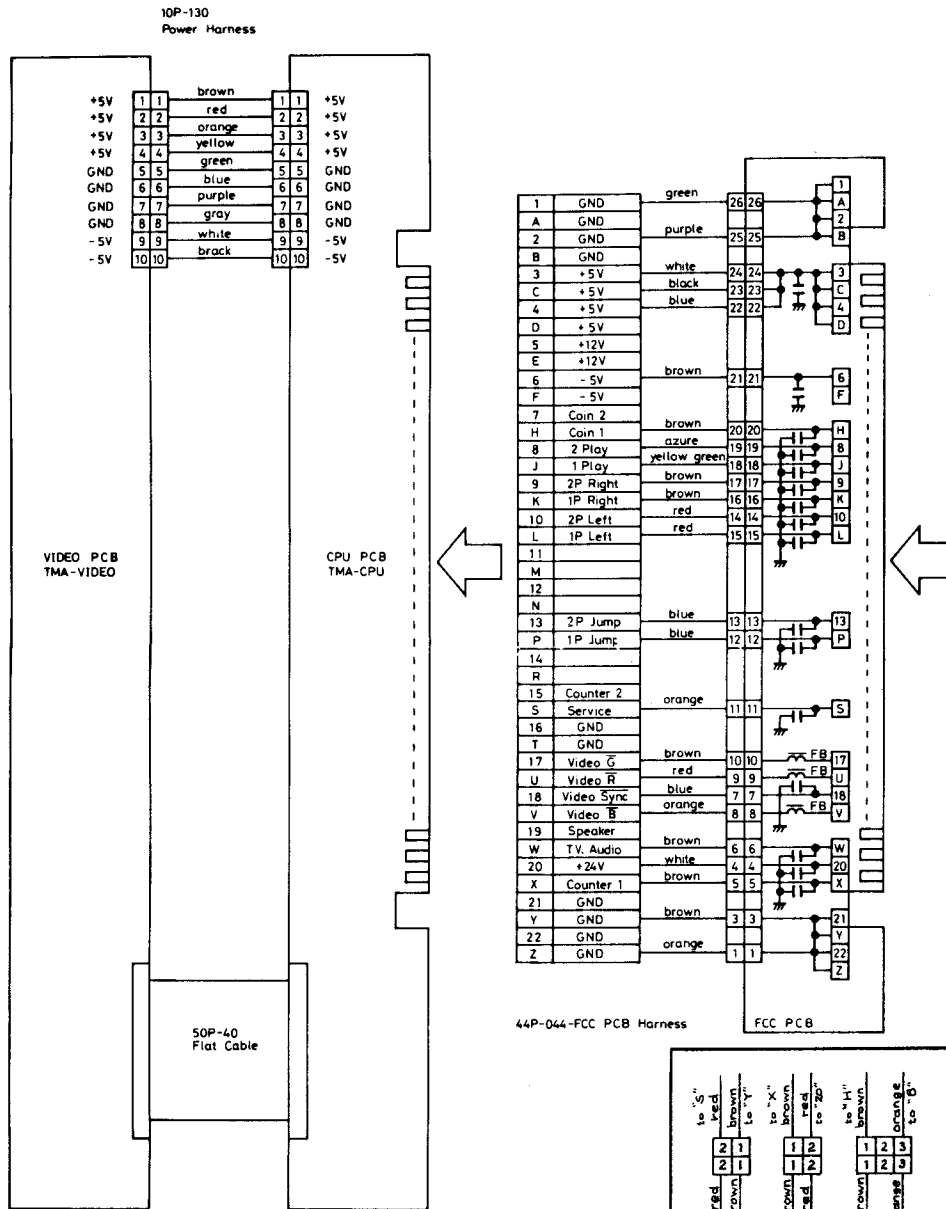
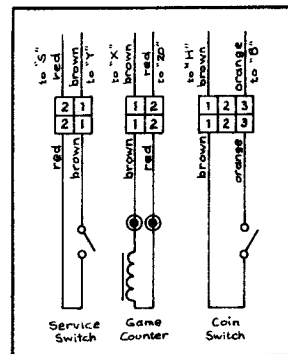
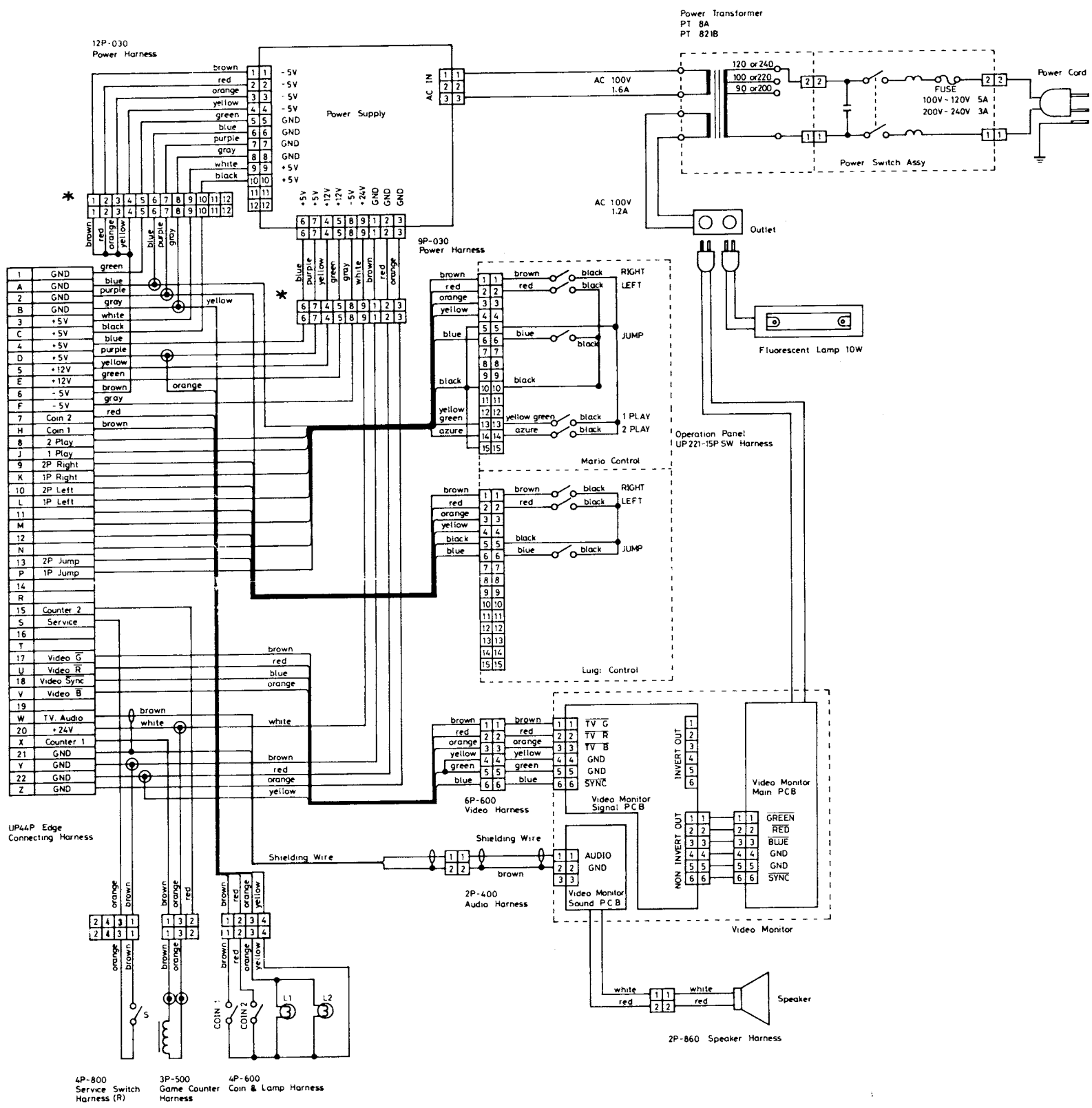

Fig 16
Wiring and Connection



This Connection is for
DONKY KONG or DONKY KONG JUNIOR



* NOTE: PLEASE DISREGARD THIS CONNECTOR IN CASE OF TKG AND DJR, WIRE HARNESS



SERVICE DEPARTMENT

Dear Distributor:

In addition to the steps you have already done, we felt it would benefit your customers if the previous cabinet and coin selector problems were checked to ensure the modifications had been done. Below is the list of service bulletins which deal with these problems.

We have included copies of these service bulletins:

- | | |
|----------|-----------------|
| TKG-05 | Slam Switch |
| DJR-01 | Upper Coin Door |
| Hinge | |
| DJR-92 | Model 730A Coin |
| Selector | |

Sincerely,

Nintendo of America, Inc.

Nintendo®

SERVICE DEPARTMENT

BULLETIN # DJR-01

GAME: Donkey Kong Jr.
SUBJECT: Upper Coin Door Hinge

It has been brought to our attention that a flattened straw or similar object can be passed through the center opening in the upper hinge. If the object makes contact with the coin switch, it can be used to run up multiple credits.

The solution is to block the opening with a flange made of wood or metal. This flange should be mounted to the inside of the cabinet and can be obtained from us as a retrofit kit.

This problem is present in all Radar Scope uprights, Donkey Kong uprights and early Donkey Kong Jr. uprights.

Nintendo®

SERVICE DEPARTMENT

BULLETIN # DJR-02

GAME: Donkey Kong Jr.
SUBJECT: Model #730A Coin Selector

It has come to our attention that there is a problem with the model #730A coin selector in that a nickel or a penny, if flipped through the entry just right, will continue through the mechanism and establish credits.

The solution to this problem is to add a small metal piece to the selector as shown in the enclosed drawing. This piece can be made from 18 gauge steel or even a paper clip as shown in the drawing. This piece is available at no charge. The threaded hole in the selector is an M3 x 6 MM size. If you cannot locate a screw this size, you can remove one of the machine screws from the power supply cage.

Nintendo®

SERVICE DEPARTMENT

BULLETIN

GAME: Donkey Kong Donkey Kong Jr., Popeye, Mario Bros.
SUBJECT: Slam Switch

In order to prevent the accumulation of free credits by kicking the coin door, a slam switch should be added.

In all cases the switch (a "normally open" weighted reed switch) should be mounted on the coin door. Connect one side of the slam switch to the brown wire on the coin switch (ground). The other side of the slam switch should be connected to a wire which will be run through the wiring harness to the CPU board. At this point the installations vary for the four (4) games.

Donkey Kong:

TKG2 and TKG3: Attach to Test Point 8, at board coordinates 3L

TKG4: Attach to Test Point 2-RESET, at board coordinates 1L

Donkey Kong Jr.:

Attach to Test Point 2 - RESET, at board coordinates 1L

Popeye:

Attach to C13 (47 F electrolytic capacitor), " "side, at board coordinates 2N

Mario Bros.:

Attach to C38 (100 electrolytic capacitor), " " side, at board coordinates 4F

PP-7B POWER SUPPLY SCHEMATIC

© 1983 Nintendo of America Inc.

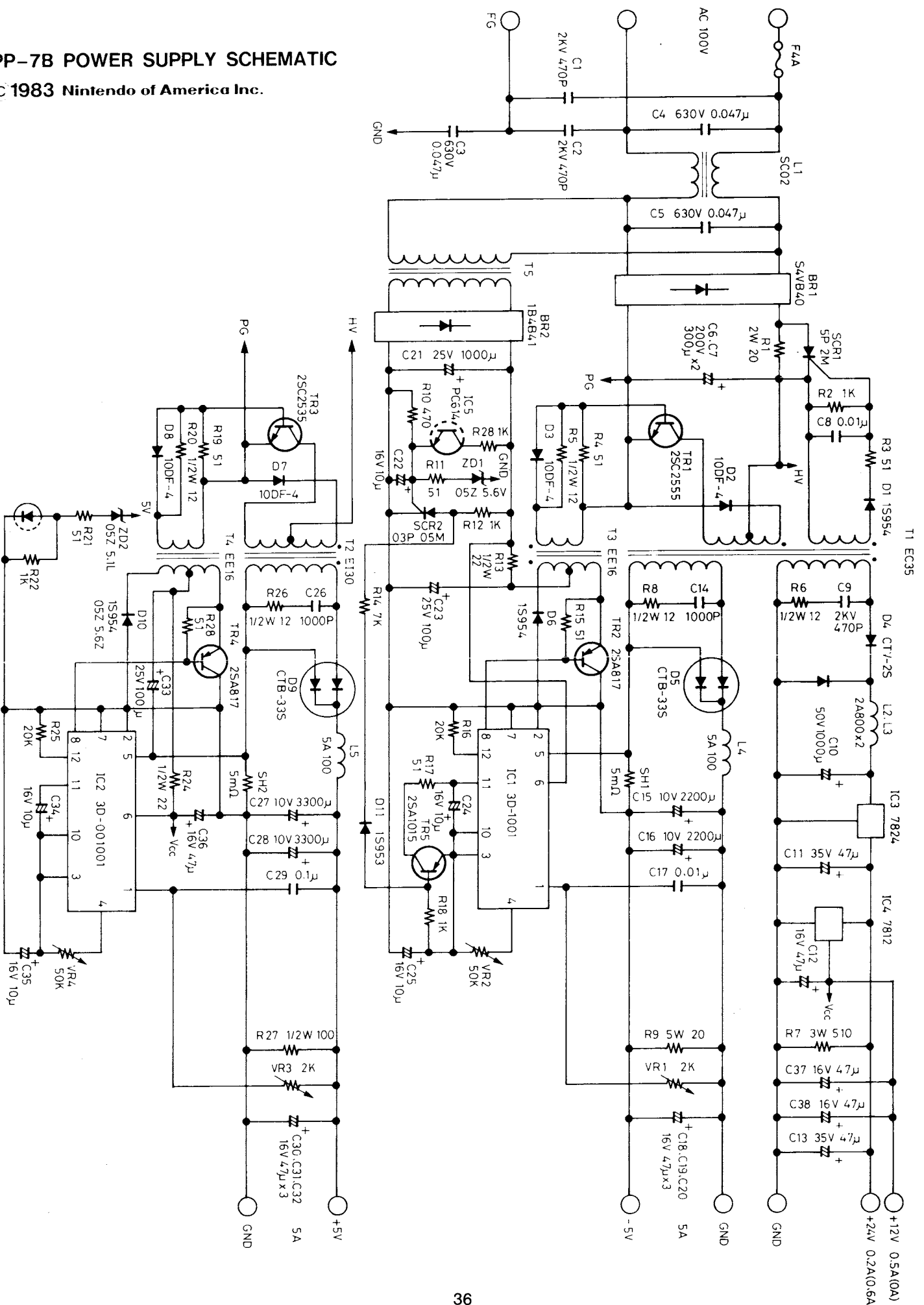

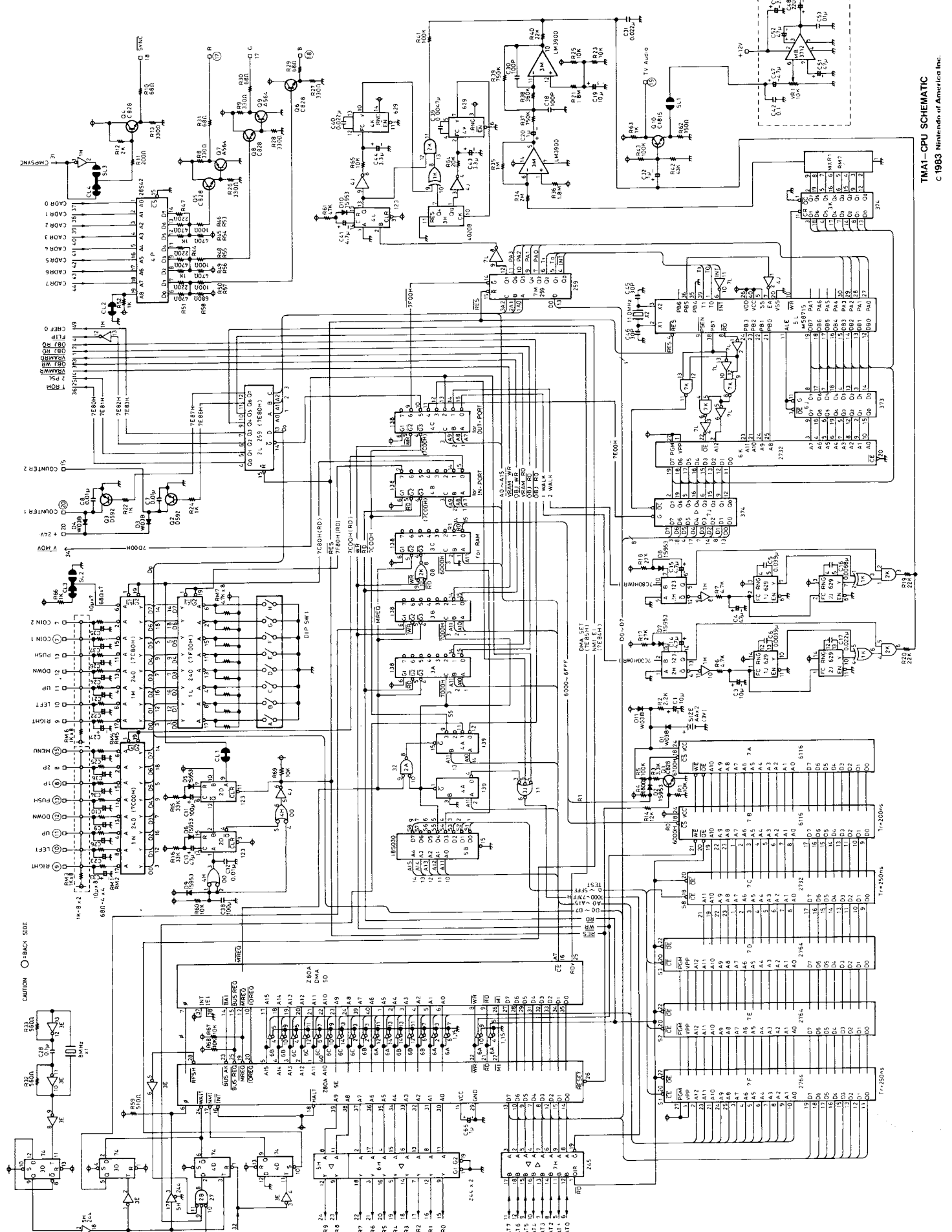

TMA1-CPU SCHEMATIC
 © 1983 Nintendo of America Inc.

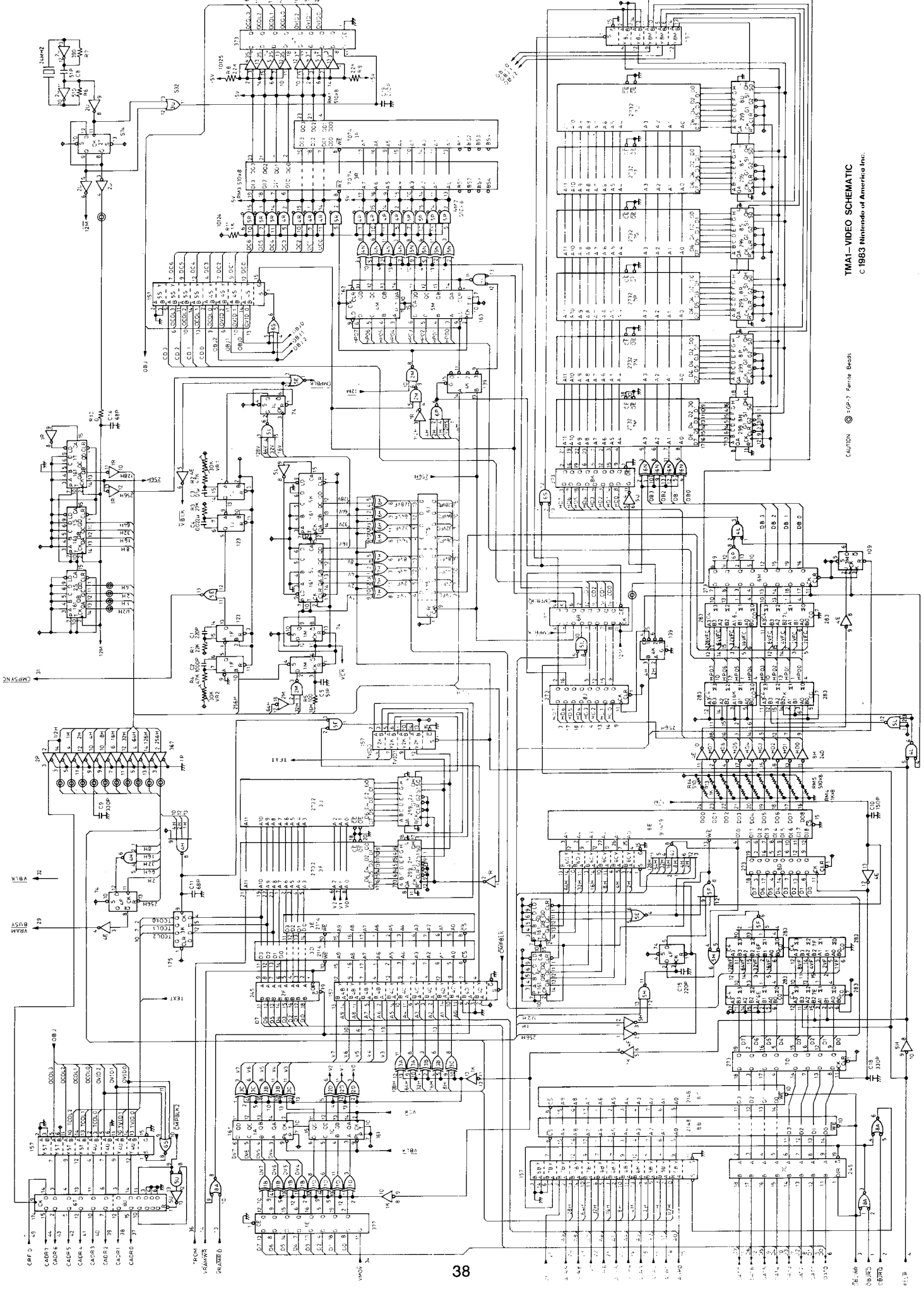

TMA1-VIDEO SCHEMATIC
 © 1983 Nintendo of America Inc.

CAUTION © EGP-7 Ferrite Beads

TMA-1 Nintendo-Pak Parts List

Item	Part #	Name Of Part	Remarks
1	TMAU-21-00	TMA1 Complete P.C. Board Set	
2	TMAU-21-01	TMA1 CPU Complete P.C. Board Assembly	
3	TMAU-22-01	TMA1 Video Complete P.C. Board Assembly	
4	TMAU-23-01	044 FCC P.C. Board	
5	TMAK-12-12	TMA Name Plate 600W	
6	TMAK-12-13	TMA Front Screen 600W	
7	TKGU-01-53	Front Screen Frame	
8	TMAU-12-23	TMA Side Decal	
9	DJRU-19-01	Power Transformer Unit	
10	TKGU-18-01	Power Supply Unit (PP-7B)	
11	DJRU-19-01-01	PT-821B Power Transformer Only	
12	TPPU-01-01-10	Shield Cage	
13	TPPU-01-01-11	Shield Cover	
14	TPPU-01-50	Monitor Mtg. Bracket (Left)	
15	TPPU-01-51	Monitor Mtg. Bracket (Right)	
16	TPPU-01-52	Monitor Support Bar	
17	TPPU-01-67	Black Cardboard Bezel	
18	TMAU-41-15	44P044-FCC PCB Harness	
19	TMAK-41-01	C-UP44P-044 Edge Connecting Main Harness	For Only TKG/DJR Replacement
20	TMAU-41-16	UP44P-044 Edge Connecting Harness	For Only TPP Replacement
21	DJR-89-08	9P-030 Power Harness	For Only TPP Replacement
22	DJR-89-09	12P-030 Power Harness	For Only TPP Replacement

Item	Part #	Name Of Part	Remarks
1	TMAK-14-16	Complete 2-Way Control Assy.	
2	TMAU-11-17	2-Way Guide Plate	
3	TKGU-23-23	E. Ring 4	
4	TKGU-23-21	Switch Collar	
5	TKGU-23-22	Lever Spring	
6	TKGU-23-20	Spring Stopper	
7	TKGU-23-13	Micro Switch VL12L (Bent)	
8	TKGU-23-17	Switch Spacer	
9	TKGU-23-16	Bearing Bracket	
10	TMAU-12-15	Lever Plate	
11	TMAU-12-14	Control Knob Plate 28D	
12	TMAU-12-16	Control Knob Collar 8L	
13	TMAU-11-18	Knob With Shaft (Replaces TKGU-01-41 Knob and TKGU23-19 Shaft)	
14	TKGU-23-34	Pal Nut	
15	TKGU-23-26	Nut Plate	
16	TKGU-23-12	Switch Button Bracket	
17	TMAU-34-18	Micro Switch VL12L (Straight)	
18	TMAU-12-18	Collar 34 x 28 x 15H	
19	TMAK-11-19	Operation Assy. Fastener	
20	TMAK-12-11	Operation Panel	
21	TKGU-23-31	Blue Button Assy	
22	TKGU-23-32	Orange Button Assy	

MARIO BROS. OPERATION PANEL ASSEMBLY PARTS (UPRIGHT)

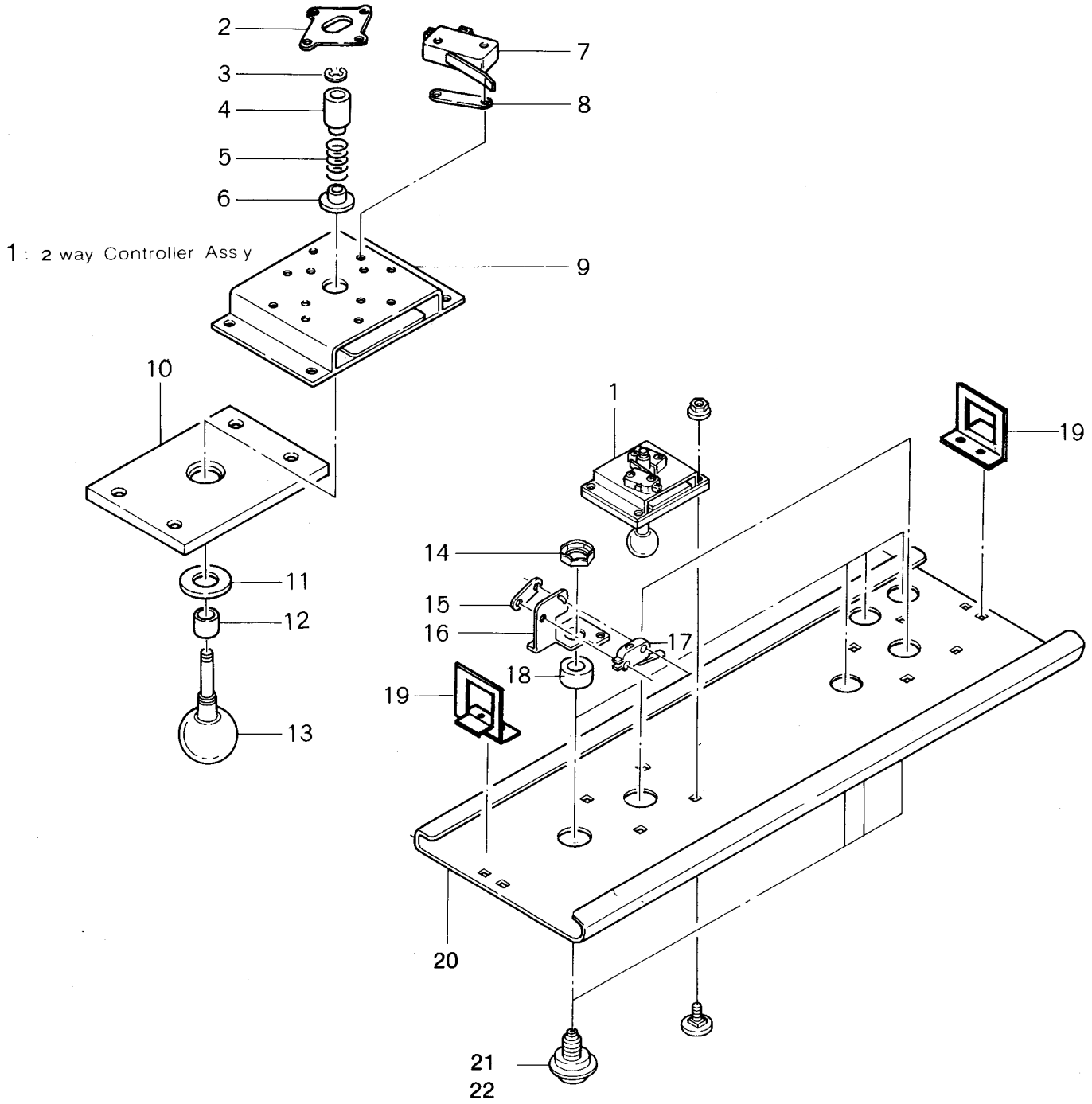

Operation Panel Assembly

PARTS LIST: TMAI-CPU PCB Assembly

No.	DESCRIPTION (Reference Designations and Locations)
TMAU-21-01	TMA1-CPU Complete PCB Assembly
TMAU-21-11	Z80A Microprocessor (5E)
TMAU-21-12	Z80ADMA DMA Controller (5D)
TMAU-21-13	3191 (8039) Microprocessor (5L)
TMAU-21-14	2732 4K byte EPROM 350ns (6K)
TMAU-21-15	2764 8K byte EPROM 450ns TMA1-C-7D (7D)
TMAU-21-16	2764 8K byte EPROM 450ns TMA1-C-7E (7E)
TMAU-21-17	2764 8K byte EPROM 450ns TMA1-C-7F (7F)
TMAU-21-18	6116 16K byte C-MOS RAM 200ns (7A, 7B)
TMAU-21-19	LM3900 Audio Amplifier (3M)
TMAU-21-20	4020B C-MOS Buffer (3H)
TMAU-21-21	TBP28S42N 512×8bit Bipolar ROM (4P)
TMAU-21-22	TBP18S030 32×8bit Bipolar ROM (5B)
TMAU-21-23	74HC374 C-MOS Octal 3 State D-Type Flip Flop (3K)
TMAU-21-24	74LS00 Quad 2-Input NAND (4H, 7K)
TMAU-21-25	74LS04 Hex Inverter (1H, 3E, 4J, 7L)
TMAU-21-26	74LS08 Quad 2-Input AND (2K)
TMAU-21-27	74LS11 Triple 3-Input AND (3J)
TMAU-21-28	74LS27 Triple 3-Input NOR (2B)
TMAU-21-29	74LS32 Quad D Type Flip-Flop (2A)
TMAU-21-30	74LS74 Dual D Type Flip-Flop (3D, 4D)
TMAU-21-31	74LS86 Quad 2-Input EXOR (1K)
TMAU-21-32	74LS123 Dual Re-triggerable Single Shot (2H, 2D, 4L)
TMAU-21-33	74LS138 3 To 8 Demultiplexer (3A, 3B, 3C, 4B, 4C)
TMAU-21-34	74LS139 Dual 2 To 4 Line Decoder (4A)
TMAU-21-35	74LS240 Octal Inverted Buffer (1L, 1M, 1N)
TMAU-21-36	74LS244 Octal 3 State Bus Buffer (5H, 6H)
TMAU-21-37	74LS245 Octal Bus Transceiver (7H)
TMAU-21-38	74LS259 8-bit Addressable Latches (2L, 7M)
TMAU-21-39	74LS367 Hex Bus Driver (6A, 6B, 6C)
TMAU-21-40	74LS373 Octal 3-State D-Latches (6J)
TMAU-21-41	74LS374 Octal 3-State D-Type Flip Flop (7J)
TMAU-21-42	74LS629 Voltage Control Oscillators (1J, 2J, 4K)
TMAU-21-43	2SD592 Silicon PNP Transistor (Q2, Q3)
TMAU-21-44	2SC828 Silicon NPN Transistor (Q8, Q5, Q6, Q1, Q4)
TMAU-21-45	2SA564 Silicon PNP Transistor (Q7, Q9)
TMAU-21-46	2SC1815 Silicon NPN Transistor (Q10)
TMAU-21-47	LS953 Diode (D2, D5, D6, D8, D7, D9, D10)
TMAU-21-48	WO3B Diode (D1, D3, D4, D11)
TMAU-21-49	68 Ohm 1/4W ±5% Resistor (R10, R29, R30, R31)
TMAU-21-50	100 Ohm 1/4W ±5% Resistor (R55, R57, R53)
TMAU-21-51	150 Ohm 1/4W ±5% Resistor (R62)

No.	DESCRIPTION (Reference Designations and Locations)		
TMAU-21-52	200	Ohm 1/4W $\pm 5\%$ Resistor	(R11)
TMAU-21-53	220	Ohm 1/4W $\pm 5\%$ Resistor	(R44, R47, R50)
TMAU-21-54	330	Ohm 1/4W $\pm 5\%$ Resistor	(R13, R8, R9, R26, R27, R28)
TMAU-21-55	470	Ohm 1/4W $\pm 5\%$ Resistor	(R46, R48, R51, R54, R56)
TMAU-21-56	510	Ohm 1/4W $\pm 5\%$ Resistor	(R59)
TMAU-21-57	560	Ohm 1/4W $\pm 5\%$ Resistor	(R32, R33)
TMAU-21-58	680	Ohm 1/4W $\pm 5\%$ Resistor	(R4, R58)
TMAU-21-59	1K	Ohm 1/4W $\pm 5\%$ Resistor	(R22, R24, R45, R49, R52, R63, R66)
TMAU-21-60	2K	Ohm 1/4W $\pm 5\%$ Resistor	(R12)
TMAU-21-61	2.2K	Ohm 1/4W $\pm 5\%$ Resistor	(R2)
TMAU-21-62	3.3K	Ohm 1/4W $\pm 5\%$ Resistor	(R3)
TMAU-21-63	4.7K	Ohm 1/4W $\pm 5\%$ Resistor	(R6, R7)
TMAU-21-64	10K	Ohm 1/4W $\pm 5\%$ Resistor	(R1, R23, R25, R60, R65, R67, R68, R69)
TMAU-21-65	12K	Ohm 1/4W $\pm 5\%$ Resistor	(R14)
TMAU-21-66	20K	Ohm 1/4W $\pm 5\%$ Resistor	(R64, R17, R18)
TMAU-21-67	22K	Ohm 1/4W $\pm 5\%$ Resistor	(R19, R20, R40)
TMAU-21-68	33K	Ohm 1/4W $\pm 5\%$ Resistor	(R16, R15)
TMAU-21-69	43K	Ohm 1/4W $\pm 5\%$ Resistor	(R42)
TMAU-21-70	47K	Ohm 1/4W $\pm 5\%$ Resistor	(R61)
TMAU-21-71	100K	Ohm 1/4W $\pm 5\%$ Resistor	(R43, R5, R41)
TMAU-21-72	360K	Ohm 1/4W $\pm 5\%$ Resistor	(R38)
TMAU-21-73	750K	Ohm 1/4W $\pm 5\%$ Resistor	(R37, R39)
TMAU-21-74	1M	Ohm 1/4W $\pm 5\%$ Resistor	(R35)
TMAU-21-75	1.8M	Ohm 1/4W $\pm 5\%$ Resistor	(R36, R21)
TMAU-21-76	2M	Ohm 1/4W $\pm 5\%$ Resistor	(R34)
TMAU-21-77	Octal 1K	Ohm Series Resistor Array	(RM3, RM6)
TMAU-21-78	Octal 4.7K	Ohm Series Resistor Array	(RM7)
TMAU-21-79	Hex 68	Ohm Series Resistor Array	(RM1, RM2, RM4, RM5)
TMAU-21-80	Rader Matrix	10K Ohm \times 20K Ohm	(MXR1)
TMAU-21-81	30PF	50V Ceramic-Disc Capacitor	(C45, C46)
TMAU-21-82	0.01 μ F	50V Ceramic-Disc Capacitor	(C7, C8, C12, C60~C91)
TMAU-21-83	100P	50V Styrol Capacitor	(C18, C30)
TMAU-21-84	0.0039 μ F	50V Film Capacitor	(C6)
TMAU-21-85	0.0047 μ F	50V Film Capacitor	(C39)
TMAU-21-86	0.0068 μ F	50V Film Capacitor	(C16)
TMAU-21-87	0.022 μ F	50V Film Capacitor	(C17, C40, C31)
TMAU-21-88	0.039 μ F	50V Film Capacitor	(C5)
TMAU-21-89	0.1 μ F	50V Film Capacitor	(C28)
TMAU-21-90	1 μ F	50V Al. Electrolytic Radial Capacitor	(C32, C29)
TMAU-21-91	3.3 μ F	50V Al. Electrolytic Radial Capacitor	(C43, C44)
TMAU-21-92	10 μ F	50V Al. Electrolytic Radial Capacitor	(C9, C10, C19~C27) (C33~C37)

No.	DESCRIPTION (Reference Designations and Locations)
TMAU-21-93	47 μ F 16V Al. Electrolytic Axial Capacitor (C13)
TMAU-21-94	100 μ F 16V Al. Electrolytic Axial Capacitor (C11, C38)
TMAU-21-95	470 μ F 16V Al. Electrolytic Axial Capacitor (C2, C54~C56)
TMAU-21-96	1 μ F 10V Tantalum Radial Capacitor (C50)
TMAU-21-97	4.7 μ F 10V Tantalum Radial Capacitor (C4, C14, C15, C41)
TMAU-21-98	10 μ F 10V Tantalum Radial Capacitor (C1, C3)
TMAU-21-99	8.00MHz Crystal (X1)
TMAU-21-100	11.00MHz Crystal (X2)
TMAU-21-101	NC5892-01 MINI BUS BAR
TMAU-21-102	NC2158-07 MINI BUS BAR
TMAU-21-103	16Pin Dip IC Socket (5B)
TMAU-21-104	20Pin Dip IC Socket (4P)
TMAU-21-105	24Pin Dip IC Socket (6K)
TMAU-21-106	28Pin Dip IC Socket (7D, 7E, 7F)
TMAU-21-107	40Pin Dip IC Socket (5E, 5L)
TMAU-21-108	8-Station Single-Throw DIP Bit Switch (SW1)
TMAU-21-109	50Pin Flat Cable Header (P1)
TMAU-21-110	10Pin Connector Receptacle (P2)
TMAU-21-111	Battery Case TYPE32-4 UM3 \times 2)
TMAU-21-112	Philips Head Machine Screw (With Spring Washer M2.6 \times 8)
TMAU-21-113	Flat Washer M2.6
TMAU-21-114	Nut Plate M2.6 Beaded Wire Tie
TMAU-21-115	T314 Ferrite Beads (FC1~FC9)
TMAU-21-116	Dry Battery UM-3

PARTS LIST : TMA1-VIDEO PCB Assembly

No.	DESCRIPTION (Reference Designations and Locations)
TMAU-22-01	TMA1-VIDEO Complete PCB Assembly
TMAU-22-11	2732 4K byte EPROM 250ns TMA-C-3F (3F)
TMAU-22-12	2732 4K byte EPROM 250ns TMA-C-3J (3J)
TMAU-22-13	2732 4K byte EPROM 250ns TMA-C-7M (7M)
TMAU-22-14	2732 4K byte EPROM 250ns TMA-C-7N (7N)
TMAU-22-15	2732 4K byte EPROM 250ns TMA-C-7P (7P)
TMAU-22-16	2732 4K byte EPROM 250ns TMA-C-7S (7S)
TMAU-22-17	2732 4K byte EPROM 250ns TMA-C-7T (7T)
TMAU-22-18	2732 4K byte EPROM 250ns TMA-C-7U (7U)

N o.	DESCRIPTION (Reference Designations)	
TMAU-22-19	2114 1K×4 bit RAM 200ns	(3D, 3E)
TMAU-22-20	2148 1K×4 bit RAM 55ns	(8B, 8C)
TMAU-22-21	93419 64×9 bit Bipolar RAM 70ns	(8E)
TMAU-22-22	7074 256×4 bit ECL RAM 10ns	(3P, 3R)
TMAU-22-23	10124 Quadruple TTL-TO-ECL Translators	(4P, 4R, 5P, 5R)
TMAU-22-24	10125 Quadruple ECL-TO-TTL Translators	(3S, 3T)
TMAU-22-25	74S04 Shottky Hex Inverter	(2U)
TMAU-22-26	74S32 Shottky Quad 2-Input OR	(3U)
TMAU-22-27	74S74 Shottky Dual D-Type Flip-Flop	(2T)
TMAU-21-24	74LS00 Quad 2-Input NAND	(2M, 5H)
TMAU-22-28	74LS02 Quad 2-Input NOR	(1K, 5E, 5U)
TMAU-21-25	74LS04 Hex Inverter	(1R, 4E)
TMAU-21-26	74LS08 Quad 2-Input AND	(8A)
TMAU-22-29	74LS10 Triple 3-Input NAND	(5L)
TMAU-22-30	74LS20 Dual 4-Input NAND	(4H, 5F, 6P)
TMAU-21-28	74LS27 Triple 3-Input NOR	(6S)
TMAU-22-31	74LS30 8-Input NAND	(4J)
TMAU-21-29	74LS32 Quad D-Type Flip-Flop	(4L)
TMAU-21-30	74LS74 Dual D-Type Flip-Flop	(1L, 1M, 4F)
TMAU-21-31	74LS86 Quad 2-Input EXOR	(1B, 1D, 2D, 3A, 3B, 3C) (4N, 5N, 6H, 6N, 7H)
TMAU-22-32	74LS109 Dual J-K Flip-Flop	(3M)
TMAU-21-32	74LS123 Dual Retriggerable Single Shot	(1F, 1H)
TMAU-21-34	74LS139 Dual 2-TO-4 Line Decocler	(4K)
TMAU-22-33	74LS157 Quad 2-To-1 Line Data Selector	(2K, 4B, 4C, 4D, 4S, 4U, 5, 5S5T, 6C, 6D, 7B, 8M, 8N)
TMAU-22-34	74LS161 Synchronous 4 bit Counter	(1C, 1S, 1T, 2S, 5J, 5K, 5C, 5D, 1A)
TMAU-22-35	74LS163 Synchronous Presetable 4 bit Counter With Clear	(4M, 5M)
TMAU-22-36	74LS174 Hex D-Type Flip-Flop	(6T, 6U)
TMAU-22-37	74LS175 Quad D-Type Flip-Flop	(3K, 6J, 7J)
TMAU-21-35	74LS240 Octal Inverted Buffer	(8H)
TMAU-21-37	74LS245 Octal Bus Transceiver	(2F, 7C)
TMAU-22-38	74LS273 Octal D-Type Flip-Flop	(6M, 7D, 8D, 8JJ)
TMAU-22-39	74LS283 4 bit Full Adder	(6E, 6F, 6K, 6L, 7E, 7F, 7K, 7L)
TMAU-22-40	74LS299 8 bit Shift Register	(2H, 2J, 8N, 8P, 8R, 8S, 8T, 8U)
TMAU-21-39	74LS367 Hex Bus Driver	(1P, 2P)
TMAU-21-40	74LS373 Octal 3-State D-Latches	(4T, 8K)
TMAU-22-41	74LS377 Octal D-Type Flip-Flop	(1E, 6R)
TMAU-22-42	0 Ohm 1/4W ±5% Resistor	(R10)
TMAU-21-50	100 Ohm 1/4W ±5% Resistor	(R5)
TMAU-22-43	390 Ohm 1/4W ±5% Resistor	(R7)
TMAU-21-56	510 Ohm 1/4W ±5% Resistor	(R6, R14)
TMAU-21-59	1K Ohm 1/4W ±5% Resistor	(R13, R11)
TMAU-21-61	2.2K Ohm 1/4W ±5% Resistor	(R8, R9)
TMAU-21-63	4.7K Ohm 1/4W ±5% Resistor	(R2, R4)

No.	DESCRIPTION (Reference Designations and Locations)
TMAU-21-67	22K Ohm 1/4W $\pm 5\%$ Resistor (R1)
TMAU-22-44	27K Ohm 1/4W $\pm 5\%$ Resistor (R3)
TMAU-21-77	Octal 1K Ohm Series Resistor Array (RM4)
TMAU-22-45	Octal 510 Ohm Series Resistor Array (RM1, RM2, RM3, RM5)
TMAU-22-46	51PF 50V Ceramic-Disc Capacitor (C5, C8)
TMAU-22-47	68PF 50V Ceramic-Disc Capacitor (C19, C11)
TMAU-22-48	150PF 50V Ceramic-Disc Capacitor (C10)
TMAU-22-49	220PF 50V Ceramic-Disc Capacitor (C15, C1)
TMAU-22-50	330PF 50V Ceramic-Disc Capacitor (C9)
TMAU-21-82	0.01 μ F 50V Ceramic-Disc Capacitor (C20 ~ C51)
TMAU-22-51	1000PF 50V Styrol Capacitor (C2)
TMAU-21-87	0.022 μ F 50V Film Capacitor (C4)
TMAU-21-89	0.1 μ F 50V Film Capacitor (C3)
TMAU-21-95	470 μ F 16V Al. Electrolytic Axial Capacitor (C7, C13, C16)
TMAU-22-52	24.00MHz Crystal (X1)
TMAU-22-53	NC5854-00 MINI BUS BAR
TMAU-22-54	NC5870-03 MINI BUS BAR
TMAU-22-55	NC5872-08 MINI BUS BAR
TMAU-21-105	24Pin DIP IC Socket (3F, 3J, 7M, 7N, 7P, 7S, 7T, 7U)
TMAU-21-109	50Pin Flat Cable Header (P1)
TMAU-21-110	10Pin Connector Receptacle (P2)
TMAU-22-56	30K Ohm VR (VR1, VR2)
TMAU-22-57	GP-7 Ferrite Beads (FC1 ~ FC16)

PARTS LIST : TMA1-FCC PCB Assembly

No.	DESCRIPTION (Reference Designations and Locations)
TMAU-23-01	TMA1-FCC Complete PCB Assembly
TMAU-23-11	26Pin Straight Connector
TMAU-23-12	0.1 μ F 12V Ceramic Disc-Capacitor
TMAU-21-82	0.01 μ F 50V Ceramic Disc-Capacitor
TMAU-23-13	0.001 μ F 50V Ceramic Disc-Capacitor
TMAU-22-57	GP-7 Ferrite Beads

PARTS LIST : PP-7B Power Supply Assembly

No.	DESCRIPTION (Reference Designations and Locations)
DJR-18-01	(PP7B) Power P.C Board Complete Set
DJR-18-02	2SC2555 Silicon NPN Transistor (TR1)
DJR-18-03	2SA817 Silicon PNP Transistor (TR2, TR4)
DJR-18-04	2SC2535 Silicon NPN Transistor (TR3)
DJR-18-05	2SA1015 Silicon PNP Transistor (TR5)
DJR-18-06	CTV-2S Fast Recovery Center Tap Diode (D4)
DJR-18-07	CTB33S Schottky Diode (D5, D9)

No.	DESCRIPTION (Reference Designations and Locations)
DJR-18-08	S4VB40 4A/400VW Silicon Rectifier Diode (BR)
DJR-18-09	1B4B41 Silicon Rectifier Diode (BR2)
DJR-18-10	3D-1001 Hybrid IC (IC1, IC2)
DJR-18-11	7824 3 Terminal Regulator (IC3)
DJR-18-12	7812 3 Terminal Regulator (IC4)
DJR-18-13	5P4M Thyristors (SCR)
DJR-18-14	03P05M Thyristors (SCR2)
DJR-18-15	1S954 Diode (D1, D6, D10, D11)
DJR-18-16	10DF-4 Diode (D2, D3, D7, D8)
DJR-18-17	PC614 Photo Coupler (IC5)
DJR-18-18	05Z 5.6V Zener Diode (ZD1)
DJR-18-19	05Z 5.1L Zener Diode (ZD2)
DJR-18-20	05Z5.6Z Zener Diode (05Z)
DJR-18-21	470P/2KV DE070B471K2K Ceramic Capacitor (C1, C2, C9)
DJR-18-22	0.1 μ F/50V Ceramic Capacitor (C29)
DJR-18-23	0.047 μ F/630VW Film Capacitor MDD2J473M (C3, C4, C5)
DJR-18-24	0.01 μ F/50V Film Capacitor (C8, C17)
DJR-18-25	1000PF/50V Film Capacitor (C14, C26)
DJR-18-26	1000 μ F/50V Al. Electrolytic Capacitor (C10)
DJR-18-27	47 μ F/35V Al. Electrolytic Capacitor (C11, C13)
DJR-18-28	47 μ F/16V Al. Electrolytic Capacitor (C12, C18, C19, C20, C30, C31, C32, C36, C37, C38)
DJR-18-29	3300 μ F/10V Al. Electrolytic Capacitor (C27, C28, C15, C16)
DJR-18-30	100 μ F/25V Al. Electrolytic Capacitor (C23, C33)
DJR-18-31	10 μ F/16V Al. Electrolytic Capacitor (C22, C24, C25, C34, C35)
DJR-18-32	330 μ F/200V Al. Electrolytic Capacitor (C6, C7)
DJR-18-33	1000 μ F/25V Al. Electrolytic Capacitor (C21)
DJR-18-34	20 Ohm 2W Resistor (Coil Winding) (R1)
DJR-18-35	1K Ohm 1/4W \pm 5% Resistor (R2, R12, R14, R15, R18, R22)
DJR-18-36	51 Ohm 1/4W \pm 5% \pm 5% Resistor (R3, R4, R11, R15, R17, R19, R21, R23)
DJR-18-37	12 Ohm 1/2W \pm 5% Resistor (R5, R8, R20, R24, R6, R26)
DJR-18-38	470 Ohm 1/4W \pm 5% Resistor (R10)
DJR-18-39	22 Ohm 1/2W \pm 5% Resistor (R13)
DJR-18-40	20K Ohm 1/2W \pm 5% Resistor (R16, R25)
DJR-18-41	100 Ohm 1/2W \pm 5% Resistor (R27)
DJR-18-42	20 Ohm 5W Resistor (R9)
DJR-18-43	510 Ohm 3W Resistor (Metal Oxide) (R7)
DJR-18-44	50K Ohm GF06P Variable Resistor (VR2, VR4)
DJR-18-45	2K Ohm GF06P Variable Resistor (VR1, VR3)
DJR-18-46	5m Ohm Shunt Resistor (SH1, SH2)
DJR-18-47	SC-02 SC Coil (L1)
DJR-18-48	100mH 5A SF Coil (L4, L5)
DJR-18-49	800mH 2A SF Coil (L2, L3)
DJR-18-50	3D-0097 EC-35 Type Oscillator Trans (T1)
DJR-18-51	3D-0097 EI-35 Type Oscillator Trans (T2)
DJR-18-52	3D-1000 EE-16 Type Oscillator Trans (T3, T4)
DJR-18-53	4A-125V Fuse FGMB4A-125V NR Type (F)

NOTES



PRINTED IN U.S.A.