

X. WIRING AND SCHEMATIC DIAGRAMS, PARTS LISTS

TABLE OF CONTENTS

	PAGE
LOGIC BOARD ASSY. (A1)	
COMPONENT LOCATION AND PARTS LIST	26, 29
SCHEMATIC DIAGRAM (SHEET 1 OF 3)	30
SCHEMATIC DIAGRAM (SHEET 2 OF 3)	32
SCHEMATIC DIAGRAM (SHEET 3 OF 3)	35
INTERFACE BOARD ASSY. (A2)	
COMPONENT LOCATION AND PARTS LIST	38
SCHEMATIC DIAGRAM	39
COLOR/SYNC BOARD ASSY. (A18)	
COMPONENT LOCATION AND PARTS LIST	41
SCHEMATIC DIAGRAM	42
SOUND BOARD ASSY. (A6)	
COMPONENT LOCATION AND PARTS LIST	44
SCHEMATIC DIAGRAM	45
POWER SUPPLY ASSY. (A3)	
COMPONENT LOCATION AND PARTS LIST	47
SCHEMATIC DIAGRAM	48
PRIMARY POWER/FILTER BOARDS/ INTERCONNECTION DIAGRAM	50

X. WIRING AND SCHEMATIC DIAGRAMS, PARTS LISTS

LOGIC BOARD ASSY. (A1), PARTS LIST

INTEGRATED CIRCUITS

REFERENCE	DESCRIPTION	PART NO.	REFERENCE	DESCRIPTION	PART NO.
	Logic Board Assy.	MA-498			
A1	8284 CLK Driver	XO-478	M7	74157 Quad 2-input multiplexer	XO-114
A2	74LS02 Quad 2-input "NOR" gate	XO-428	M8	74LS74 Dual D-type flip flop	XO-434
A3	74161 Synchronous 4-bit counter	XO-192	M9	74S157 Quad 2-input multiplexer	XO-124
A7	74LS02 Quad 2-input "NOR" gate	XO-428	M10	74LS245 Octal bus transceiver	XO-79
A8, A9, A10	74LS273 8-bit register	XO-94	M11	74LS374 Octal D-type flip flop	XO-96
B1	8088 CPU	XO-490	M12	74LS157 Quad 2-input multiplexer	XO-390
B3	74LS373 Octal D-type flip flop	XO-445	M13, M14, M15	7489 64-bit RAM	XO-88
B4	74LS367 Hex 3-state buffer	XO-444	M16, M17	74LS174 Hex D-type flip flop	XO-442
B5	74LS08 Quad 2-input "AND" gate	XO-86	N1, N2, N3,	74S189 64-bit RAM	XO-89
B6	74HC138 1 of 8 decoder	XO-190	N4		
B7	74LS139 Dual 1 of 4 decoder	XO-419	N5, N6	74S161 Synchronous presettable binary counter	XO-488
B8, B9, B10	74LS138 1 of 8 decoder	XO-437	N7, N8, N9	74LS157 Quad 2-input multiplexer	XO-390
B11, B12, B14	74LS240 Octal buffer/line driver	XO-91	N10		
E3	74LS373 Octal D-type flip flop	XO-445	N11	74LS260 Dual 5-input "NOR" gate	XO-93
E4	74LS245 Octal bus transceiver	XO-79	N12	74LS298 Quad 2-port register	XO-118
E5 RAM0	HM6116LP-4 2K x 8 SRAM	XO-191	N13	74LS157 Quad 2-input multiplexer	XO-390
E6 RAM1	HM6166LP-4 2K x 8 SRAM	XO-191	N14	74LS00 Quad 2-input "NAND" gate	XO-427
E7 RAM2	HM6116P-4 2K x 8 SRAM	XO-195	N15	74LS30 8-input "NAND" gate	XO-432
E8 RAM3	HM6116P-4 2K x 8 SRAM	XO-195	N16, N17	74LS86 Quad 2-input "Exclusive-OR" gate	XO-435
E11 ROM0	2764-3 8K x 8 EPROM	XO-489			
E13 ROM1	2764-3 8K x 8 EPROM	XO-489	S1, S2, S3,	74L189 64-bit RAM	XO-89
E14 ROM2	2764-3 8K x 8 EPROM	XO-489	S4, S5, S6		
G1	74LS139 Dual 1 of 4 decoder	XO-419	S7	74LS04 Hex inverter	XO-418
G2, G3, G4	74157 Quad 2-input multiplexer	XO-114	S8	74LS32 Quad 2-input "OR" gate	XO-433
G5, G6, G7			S9	7408 Quad 2-input "AND" gate	XO-404
G8, G9, G10			S10, S11	93422 256 x 4 Bipolar RAM	XO-100
G11	74LS374 Octal D-type flip flop	XO-96	S12	74LS02 Quad 2-input "NOR" gate	XO-428
G12	74LS244 Octal buffer/line driver	XO-117	S13	74LS74 Dual D-type flip flop	XO-434
G13	74LS157 Quad 2-input multiplexer	XO-390	S14	7407 Hex buffer/driver	XO-384
G15	74LS86 Quad 2-input "Exclusive-OR" gate	XO-435	S15	74LS30 8-input "NAND" gate	XO-432
G16	74LS283 4-bit binary full adder	XO-95	S16, S17	74S161 Synchronous presettable binary counter	XO-488
G17	74S161 Synchronous presettable binary counter	XO-488	T1, T2, T3	74LS379 Quad D-type flip flop	XO-98
H1, H2, H4	93419 64 x 9 bipolar RAM	XO-99	T4 FGO	2764-3 8K x 8 EPROM	XO-489
H5	74LS283 4-bit binary full adder	XO-95	T5 FGI	2764-3 8K x 8 EPROM	XO-489
H6	74LS30 8-input "NAND" gate	XO-432	T6 FG2	2764-3 8K x 8 EPROM	XO-489
H7	4801AN-3 1K x 8 RAM	XO-193	T8 FG3	2764-3 8K x 8 EPROM	XO-489
H8, H9	74LS245 Octal bus transceiver	XO-79	T9, T10, T11	74LS157 Quad 2-input multiplexer	XO-390
H10	4801AN-3 1K x 8 RAM	XO-193	T12	74LS260 Dual 5-input "NOR" gate	XO-93
H12 BGO	2732A 4K x 8 EPROM	XO-485	T13	74LS32 Quad 2-input "OR" gate	XO-433
H13 BGI	2732A 4K x 8 EPROM	XO-485	T14	74LS08 Quad 2-input "AND" gate	XO-86
H15	74LS86 Quad 2-input "Exclusive-OR" gate	XO-435	T15	74LS04 Hex inverter	XO-418
H16	74LS273 8-bit register	XO-94	T16	74LS20 Dual 4-input "NAND" gate	XO-430
H17	74LS20 Dual 4-input "NAND" gate	XO-430	T17	74S161 Synchronous presettable binary counter	XO-488
K5	74LS283 4-bit binary full adder	XO-95	V4, V5, V6,	74LS166 8-bit shift register	XO-391
K6	74LS32 Quad 2-input "OR" gate	XO-433	V7		
K15	74LS04 Hex inverter	XO-418	V9, V10	74LS74 Dual D-type flip flop	XO-434
K16	74S161 Synchronous presettable binary counter	XO-488	V11	74LS20 Dual 4-input "NAND" gate	XO-430
K17	74LS86 Quad 2-input "Exclusive-OR" gate	XO-435	V12	74LS161 Synchronous presettable binary counter	XO-440
M1, M2, M3	74LS157 Quad 2-input multiplexer	XO-390	V14	74S74 Dual D-type flip flop (T.I. only)	XO-87
M4, M5			V15	74S157 Quad 2-input multiplexer	XO-124
M6	74LS161 Synchronous presettable binary counter	XO-440	V16	74S04 Hex inverter	XO-400

X. WIRING AND SCHEMATIC DIAGRAMS, PARTS LISTS LOGIC BOARD ASSY. (A1), COMPONENT LOCATION

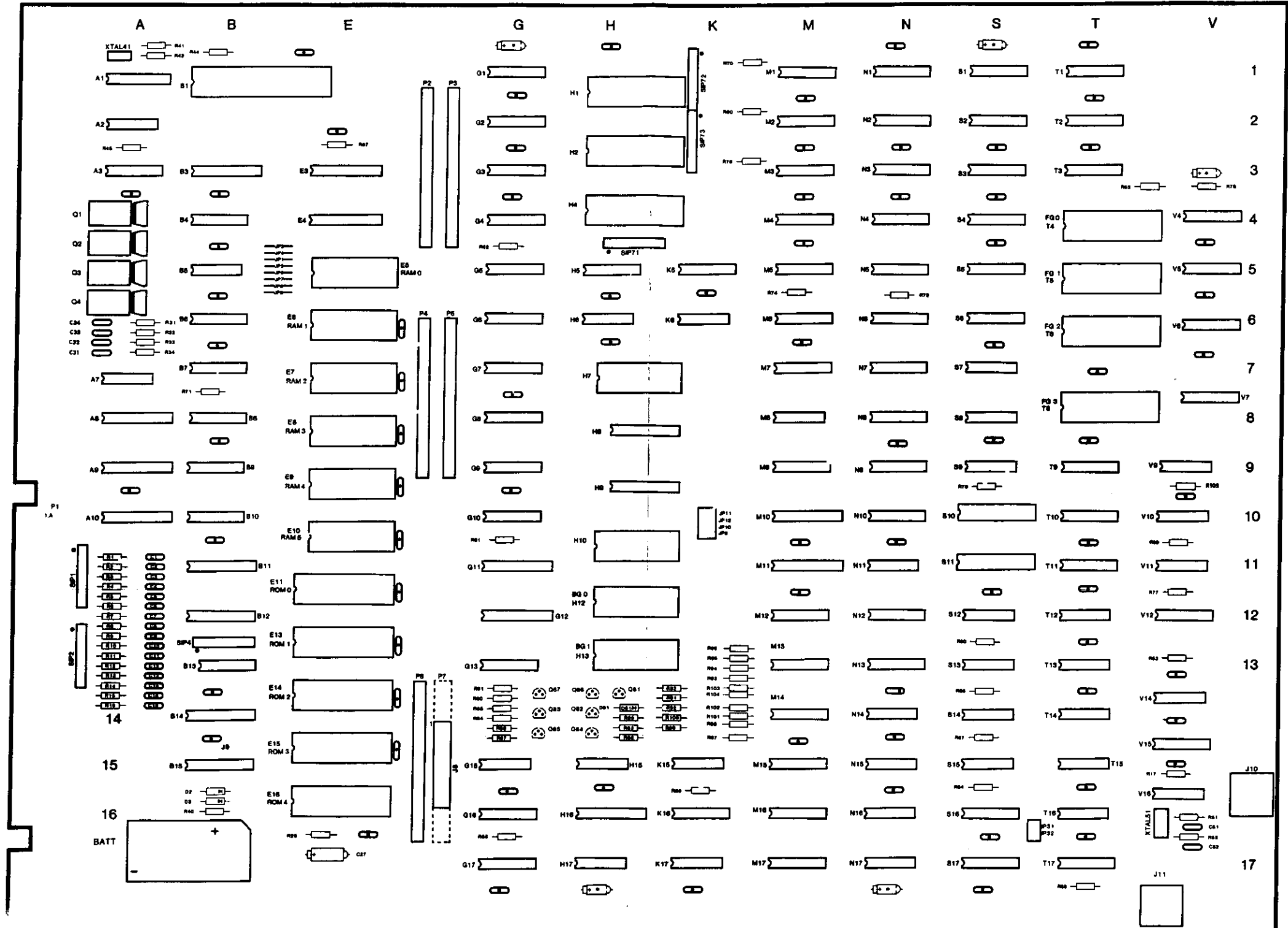

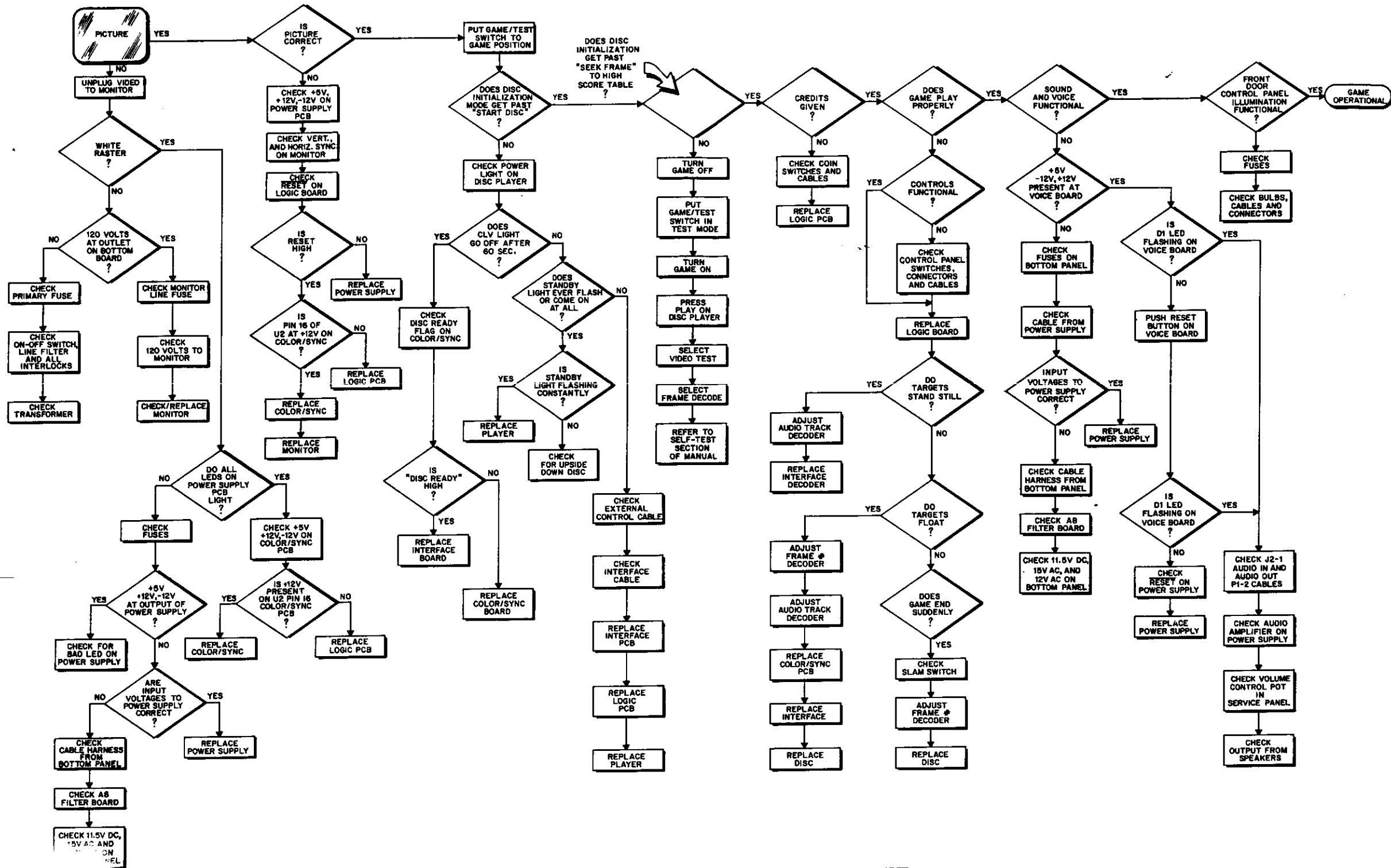

SYSTEM TROUBLESHOOTING FLOW CHART

LOGIC BOARD ASSY. (A1),
PARTS LIST (CONT.)

MISCELLANEOUS ELECTRONIC
COMPONENTS

REFERENCE	DESCRIPTION	PART NO.
BATT.	Battery, 3.6V	XO-458
B13	Dip Switch	XO-505
CH-C16	Capacitor, 0.1UF, 50V AX. CR. +80%-20%	XO-230
C27	Capacitor, 100UF, 25V EL-AX	XO-212
C31-C34	Capacitor, 0.1UF, 50V AX. CR. +80%-20%	XO-230
C51	Capacitor, 100PF, 100V CMD, 5%	XO-198
C52	Capacitor, 0.1UF, 100V CMD, 5%	XO-196
ALL UNMARKED CAPACITORS	0.1UF, 50V AX. CR. +80%-20%	XO-229
ALL UNMARKED POLARIZED CAPACITORS	10UF, 25V AX. TANT 10%	XO-127
D2, D3	Diode, 1N4454	XO-275
D81	Diode, 1N4148	XO-261
J8	Header Conn., 26 Pin	XO-712
J10, J11	Phono Jack, Right Angle	XO-618
JP9-JP12	Header Conn., 2 Pin Stick	XO-123
JP31, JP32	Header Conn., 2 Pin Stick	XO-123
Q1-Q4	Tinplate Jumper, Blue Plastic Cover	XO-122
O81-O87	Transistor, 2N6044	XO-120
R1-R17	Resistor, MFS-A70	XO-309
R-25	Resistor, 470 OHM, 5% 1/4W	X-35
R31-R34	Resistor, 1K OHM, 5% 1/4W	XO-5
R37	Resistor, 330 OHM, 5% 1/4W	XO-34
R40	Resistor, 270 OHM, 5% 1/4W	XO-68
R41, R42	Resistor, 510 OHM, 5% 1/4W	XO-25
R44, R45	Resistor, 1K OHM, 5% 1/4W	XO-5
R51, R52	Resistor, 330 OHM, 5% 1/4W	XO-34
R53, R54	Resistor, 1K OHM, 5% 1/4W	XO-5
R57, R58	Resistor, 560 OHM, 5% 1/4W	XO-36
R59-R63	Resistor, 1K OHM, 5% 1/4W	XO-5
R69-R71	Resistor, 1K OHM, 5% 1/4W	XO-5
R73, R74	Resistor, 1K OHM, 5% 1/4W	XO-5
R76-R80	Resistor, 1K OHM, 5% 1/4W	XO-5
R81	Resistor, 820 OHM, 5% 1/4W	XO-174
R82	Resistor, 100 OHM, 5% 1/4W	XO-28
R83, R84	Resistor, 15 OHM, 5% 1/4W	XO-171
R85	Resistor, 180 OHM, 5% 1/4W	XO-24
R86, R87	Resistor, 15 OHM, 5% 1/4W	XO-171
R88	Resistor, 180 OHM, 5% 1/4W	XO-24
R89, R90	Resistor, 15 OHM, 5% 1/4W	XO-171
R91	Resistor, 180 OHM, 5% 1/4W	XO-24
R92	Resistor, 1K OHM, 5% 1/4W	XO-5
R93	Resistor, 2K OHM, 5% 1/4W	XO-14
R94	Resistor, 1K OHM, 5% 1/4W	XO-5
R95	Resistor, 470 OHM, 5% 1/4W	XO-35
R96	Resistor, 240 OHM, 5% 1/4W	XO-173
R97	Resistor, 2K OHM, 5% 1/4W	XO-14
R98	Resistor, 1K OHM, 5% 1/4W	XO-5
R99	Resistor, 470 OHM, 5% 1/4W	XO-35
R100	Resistor, 240 OHM, 5% 1/4W	XO-173
R101	Resistor, 2K OHM, 5% 1/4W	XO-14
R102	Resistor, 1K OHM, 5% 1/4W	XO-5
R103	Resistor, 470 OHM, 5% 1/4W	XO-35
R104	Resistor, 240 OHM, 5% 1/4W	XO-173
R105	Resistor, 1K OHM, 5% 1/4W	XO-5
SIP1, SIP2	Resistor Pack, Sip. 4.7K OHM, 9 Pin	XO-492
SIP4	Resistor Pack, Sip. 4.7K OHM, 9 Pin	XO-493
SIP71, SIP72	Resistor Pack, Sip. 1K OHM, 9 Pin	XO-482
SIP73	Resistor Pack, Sip. 1K OHM, 9 Pin	XO-494
XTAL-41	Crystal, 15 MHZ	XO-491
XTAL-51	Crystal, 20 MHZ	XO-494
	20 Pin Dip Socket	XO-467
	22 Pin Dip Socket	XO-529
	24 Pin Dip Socket	XO-536
	28 Pin Dip Socket	XO-536
	40 Pin Dip Socket	XO-530

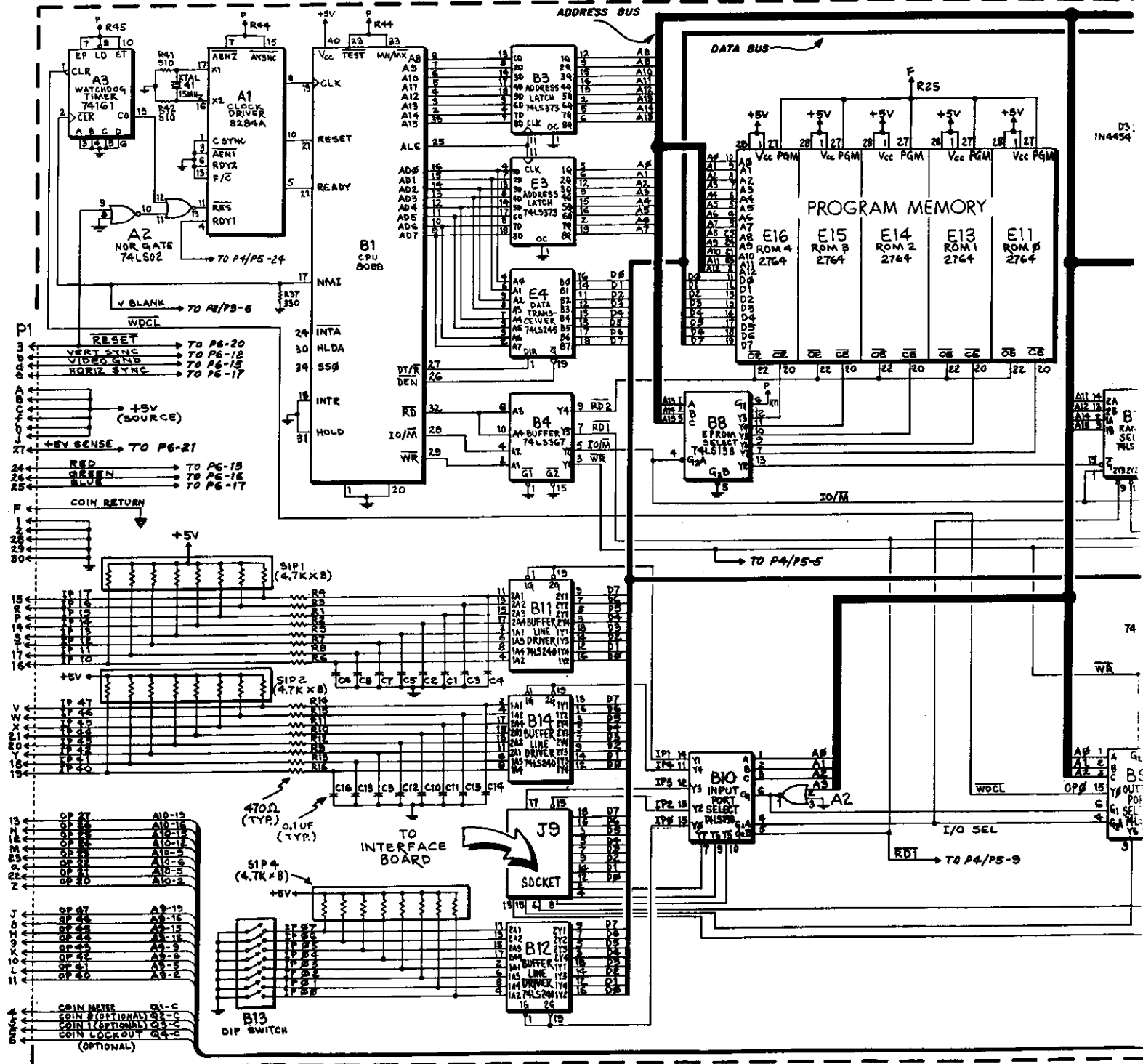

X. WIRING AND SCHEMATIC DIAGRAMS, PARTS LISTS

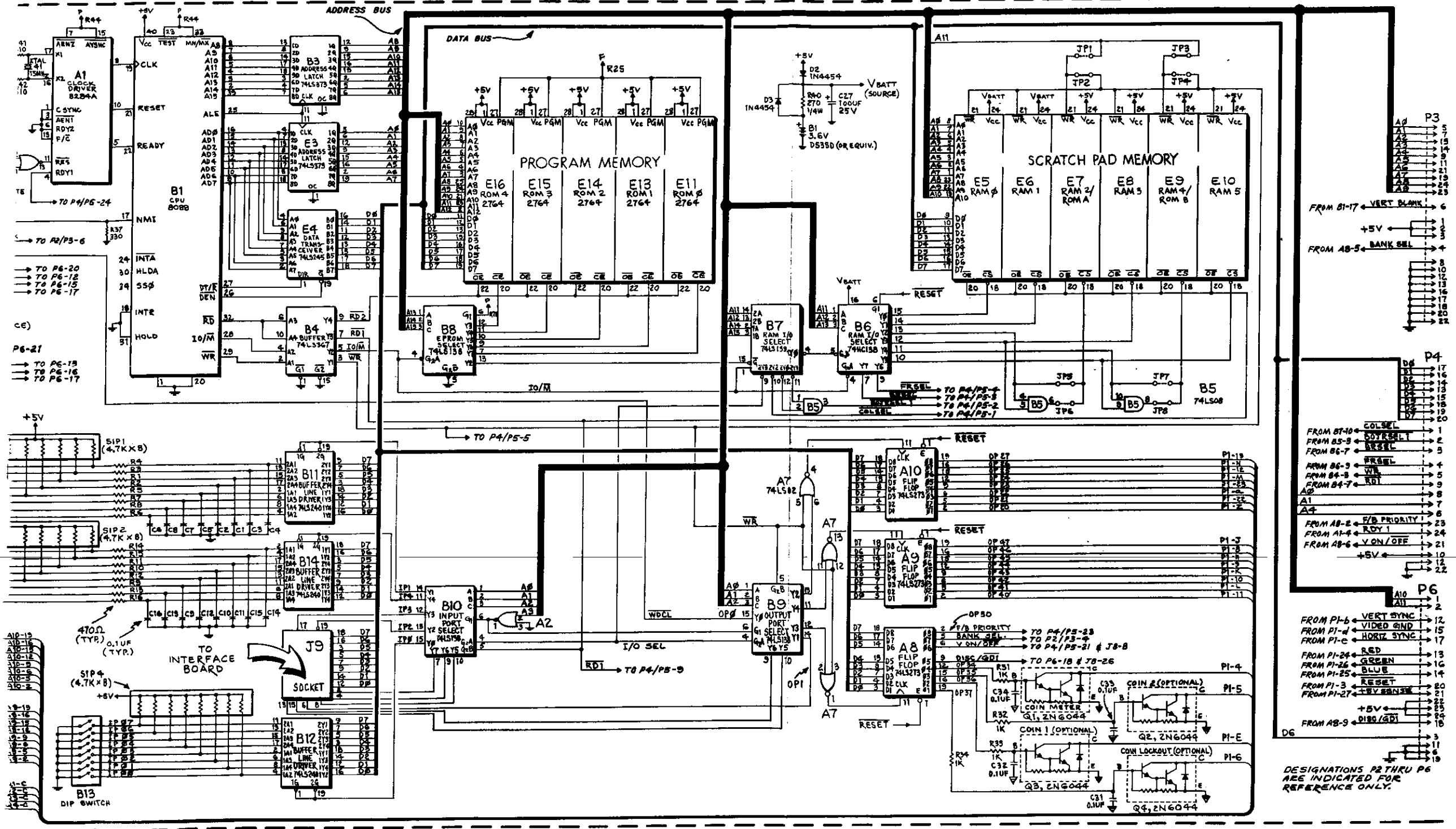

LOGIC BOARD ASSY. (A1), SCHEMATIC DIAGRAM, SHEET 1 OF 3

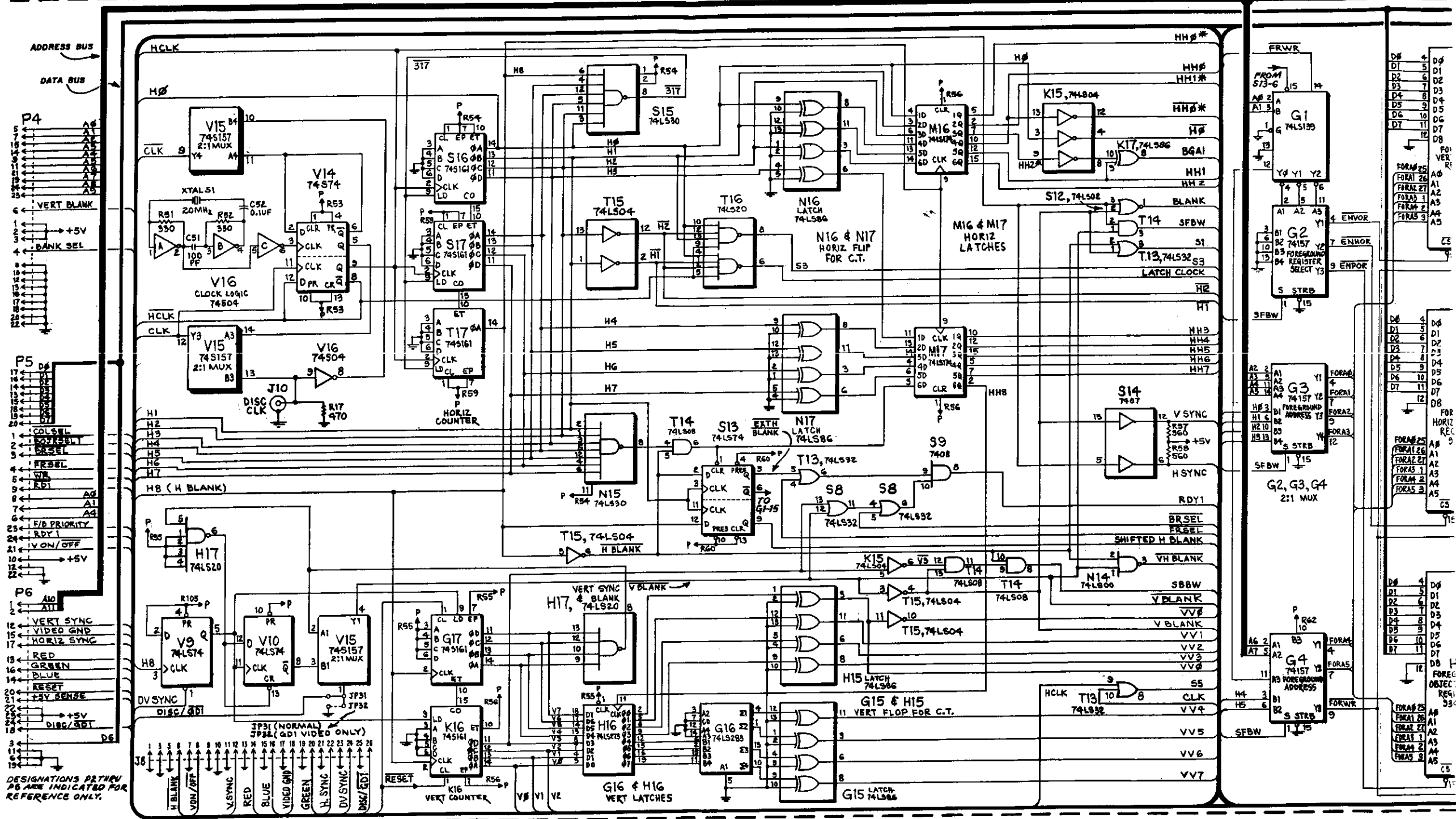

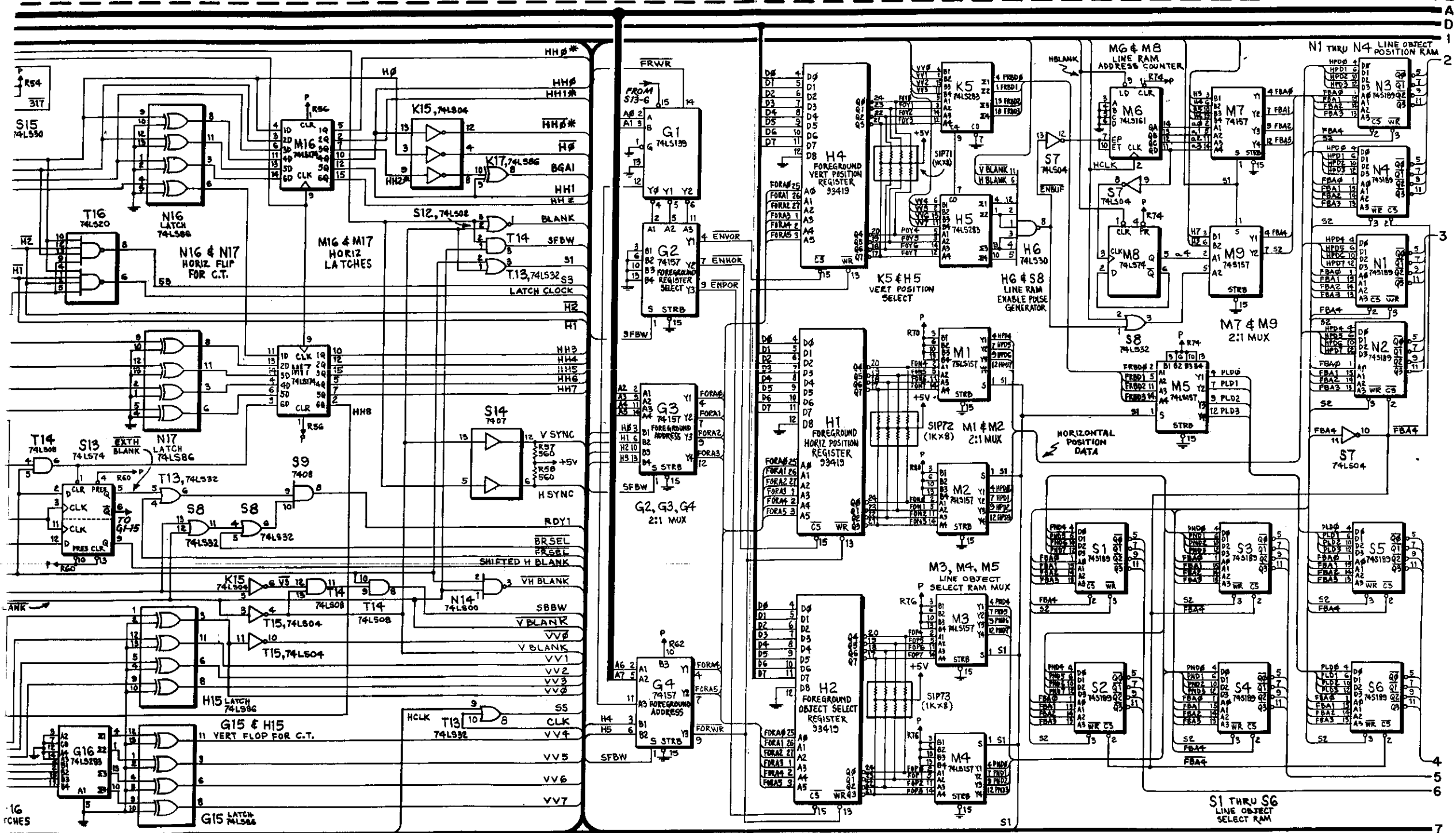

LOGIC BOARD ASSY. (A1), SCHEMATIC DIAGRAM, SHEET 2 OF 3

X. WIRING AND SCHEMATIC DIAGRAMS, PARTS LISTS

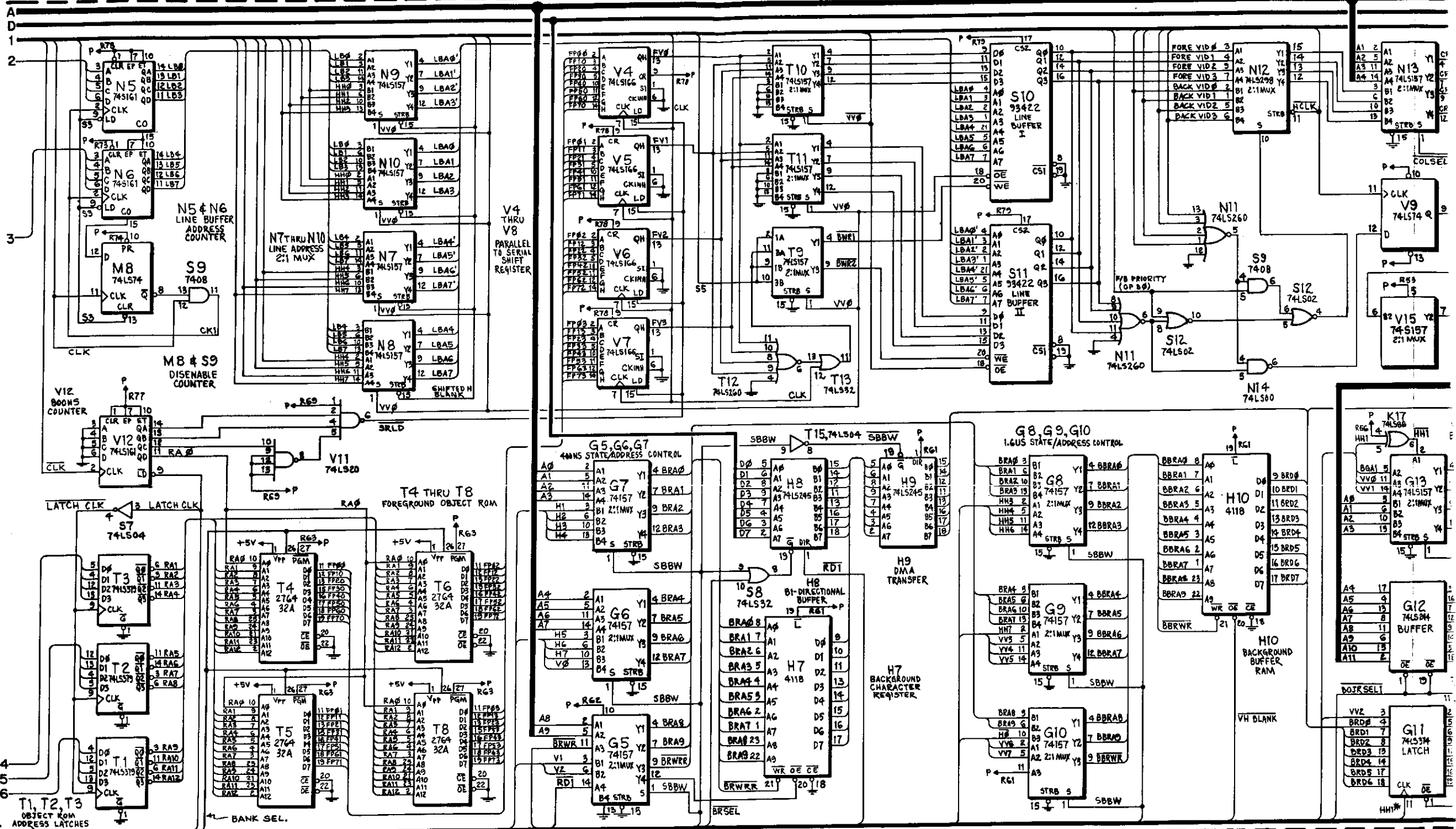

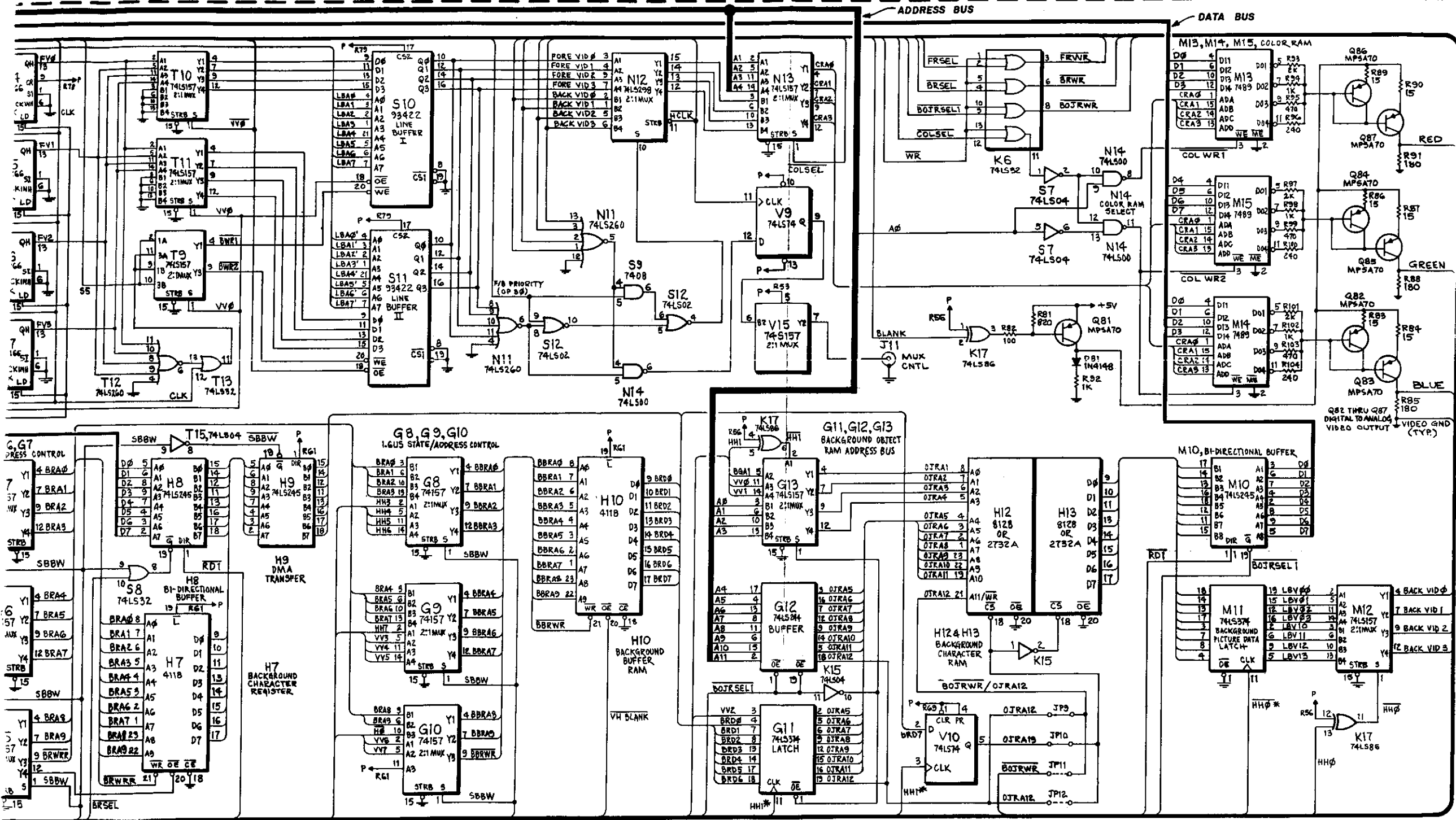

LOGIC BOARD ASSY. (A1), SCHEMATIC DIAGRAM, SHEET 3 OF 3

INTERFACE BOARD ASSY. (A2), COMPONENT LOCATION

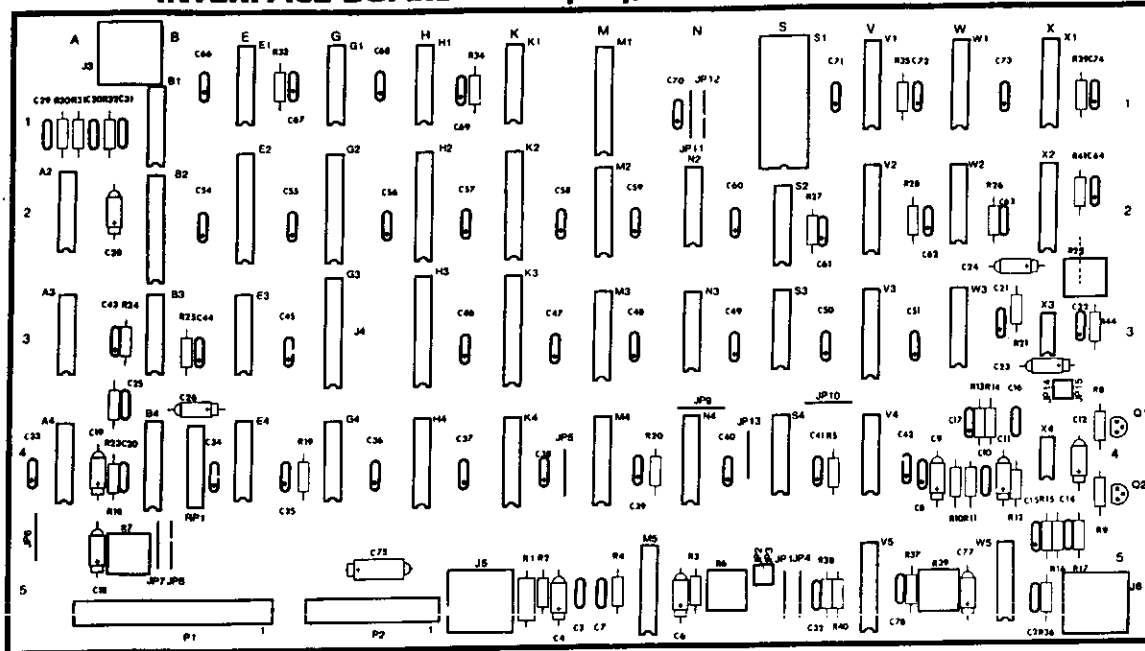

INTERFACE BOARD ASSY. (A2), PARTS LIST

REFERENCE	DESCRIPTION	PART NO.	REFERENCE	DESCRIPTION	PART NO.
	Interface Board Assy.	MA-499	R18	Resistor, 5.6K OHM, 5% 1/4W	XO-19
C2	Capacitor, 0.1UF, 50V CM-AX	XO-230	R20	Resistor, 2.2K OHM, 5% 1/4W	XO-27
C3	Capacitor, 0.1UF, 50V CM-AX, 10%	XO-269	R21	Resistor, 16K OHM, 5% 1/4W	XO-698
C4, C6	Capacitor, 0.1UF, 10V TANT-AX, 10%	XO-209	R22	Potentiometer, 10K OHM, 10% 1/4W	XO-690
C7	Capacitor, 0.01UF, 50V NPO CM-AX, 10%	XO-757	R23	Resistor, 6.2K OHM, 5% 1/4W	XO-699
C8	Capacitor, 0.1UF, 50V CM-AX, +80%-20%	XO-229	R24-R29	Resistor, 2.2K OHM, 5% 1/4W	XO-27
C9	Capacitor, 0.1UF, 10V TANT-AX, 10%	XO-209	R30, R31, R32	Resistor, 220 OHM, 5% 1/4W	XO-21
C10	Capacitor, 0.01UF, 50V CM-AX, +80%-20%	XO-695	R33, R34, R35	Resistor, 2.2K OHM, 5% 1/4W	XO-27
C11, C12	Capacitor, 0.1UF, 10V TANT-AX, 10%	XO-209	R36	Resistor, 8.2K OHM, 5% 1/4W	XO-589
C14	Capacitor, 22PF, 50V MONO CM-AX, 10%	XO-633	R37	Resistor, 180K OHM, 5% 1/4W	XO-672
C15	Capacitor, 0.1UF, 50V CM-AX, +80%-20%	XO-229	R38	Resistor, 18K OHM, 5% 1/4W	XO-590
C16	Capacitor, 22PF, 50V MONO CM-AX, 10%	XO-633	R39	Potentiometer, 50K OHM, 10% 1/4W	XO-675
C17	Capacitor, 0.1UF, 50V CM-AX, +80%-20%	XO-229	R40	Resistor, 2.2K OHM, 5% 1/4W	XO-27
C18, C19	Capacitor, 10UF, 10V TANT-AX, 10%	XO-209	R44	Resistor, 2.2K OHM, 5% 1/4W	XO-27
C20	Capacitor, 390PF, 50V CM-AX, 10%	XO-684	A2	7414 Schmitt Trigger hex inverter	XO-397
C21	Capacitor, 0.1UF, 50V CM-AX, +80%-20%	XO-229	A3	74LS04 Hex inverter	XO-418
C22	Capacitor, 0.01UF, 50V NPO CM-AX, 10%	XO-757	A4	74LS00 Quad 2-input "NAND" gate	XO-427
C23, C24	Capacitor, 0.1UF, 10V TANT-AX, 10%	XO-209	B1	74LS164 8-bit SISO shift register	XO-441
C25	Capacitor, 22PF, 50V CM-AX, +80%-20%	XO-694	G1	74LS374 Octal D-type flip flop	XO-96
C26, C28	Capacitor, 10UF, 10V TANT-AX, 10%	XO-209	G2	74LS164 8-bit SISO shift register	XO-441
C29, C30	Capacitor, 390PF, 50V CM-AX, 10%	XO-684	H2	74LS374 Octal D-type flip flop	XO-96
C31, C32	Capacitor, 82PF, 50V CM-AX, +80%-20%	XO-692	H1	74LS164 8-bit SISO shift register	XO-441
C75	Capacitor, 100UF, 25V EL-AX CM-AX, 10%	XO-212	K2	74LS244 Octal buffer/line driver	XO-117
C76	Capacitor, 0.01UF, 50V NPO CM-AX, 10%	XO-757	M1	74LS244 Octal buffer/line driver	XO-117
C77	Capacitor, 10UF, 10V TANT-AX, 10%	XO-209	M2	74LS165 8-bit PISO shift register	XO-80
ALL BRASS CAPACITORS	Capacitor, 0.1UF, 50V CM-AX, +80%-20%	XO-229	M3	74LS30 8-input "NAND" gate	XO-432
J3	Phono Jack, Right Angle	XO-618	M4	74LS161 Synchronous presettable binary counter	XO-440
J4, J5	20 Pin DIP Socket	XO-499	S1	74LS164 8-bit SISO shift register	XO-441
J6	Phono Jack, Right Angle	XO-618	S2	74LS74 Dual D-type flip flop	XO-434
J7, J8	Header Conn, 2 Pin Stick	XO-123	S3	74LS08 Quad 2-input "AND" gate	XO-86
J9, J15	Header Conn, 2 Pin Stick	XO-123	S4	74LS161 Synchronous presettable binary counter	XO-440
J10	Tinplate Jumper, Blue Plastic Cover	XO-122	V1	74LS164 8-bit SISO shift register	XO-441
J11	8 Pin Wafer Conn.	XO-339	V2, V3	74LS164 8-bit SISO shift register	XO-441
K1, K2	Transistor, 2SC195	XO-316	V4	74LS74 Dual D-type flip flop	XO-434
R1	Resistor, 4.7 OHM, 5% 1/4W	XO-697	V5	MC145388 Monostable multivibrator	XO-564
R2	Resistor, 47K OHM, 5% 1/4W	XO-30	W1	74LS191 Presettable 4-bit binary counter	XO-116
R3	Resistor, 120K OHM, 5% 1/4W	XO-601	W2	74LS74 Dual D-type flip flop	XO-434
R4, R5	Resistor, 2.2K OHM, 5% 1/4W	XO-27	W3	74LS27 Triplet 3-input "NOR" gate	XO-702
R6, R7	Potentiometer, 50K OHM, 10% 1/4W	XO-675	W5	74LS04 Hex inverter	XO-418
R8, R9	Resistor, 18K OHM, 5% 1/4W	XO-5	W6	74LS191 Presettable 4-bit binary counter	XO-116
R10, R11	Resistor, 100K OHM, 1% 1/4W	XO-758	X1	74LS190 Presettable BCD to Decade counter	XO-701
R12	Resistor, 2.2K OHM, 5% 1/4W	XO-27	X2	Decade counter	XO-631
R13	Resistor, 26.7K OHM, 1% 1/4W	XO-760	X3	NE555P Timer	XO-396
R14, R15	Resistor, 249K OHM, 1% 1/4W	XO-759	X4	JM393 Dual voltage comparator	XO-396
R16	Resistor, 26.7K OHM, 1% 1/4W	XO-760			
R17	Resistor, 2.2K OHM, 5% 1/4W	XO-27			

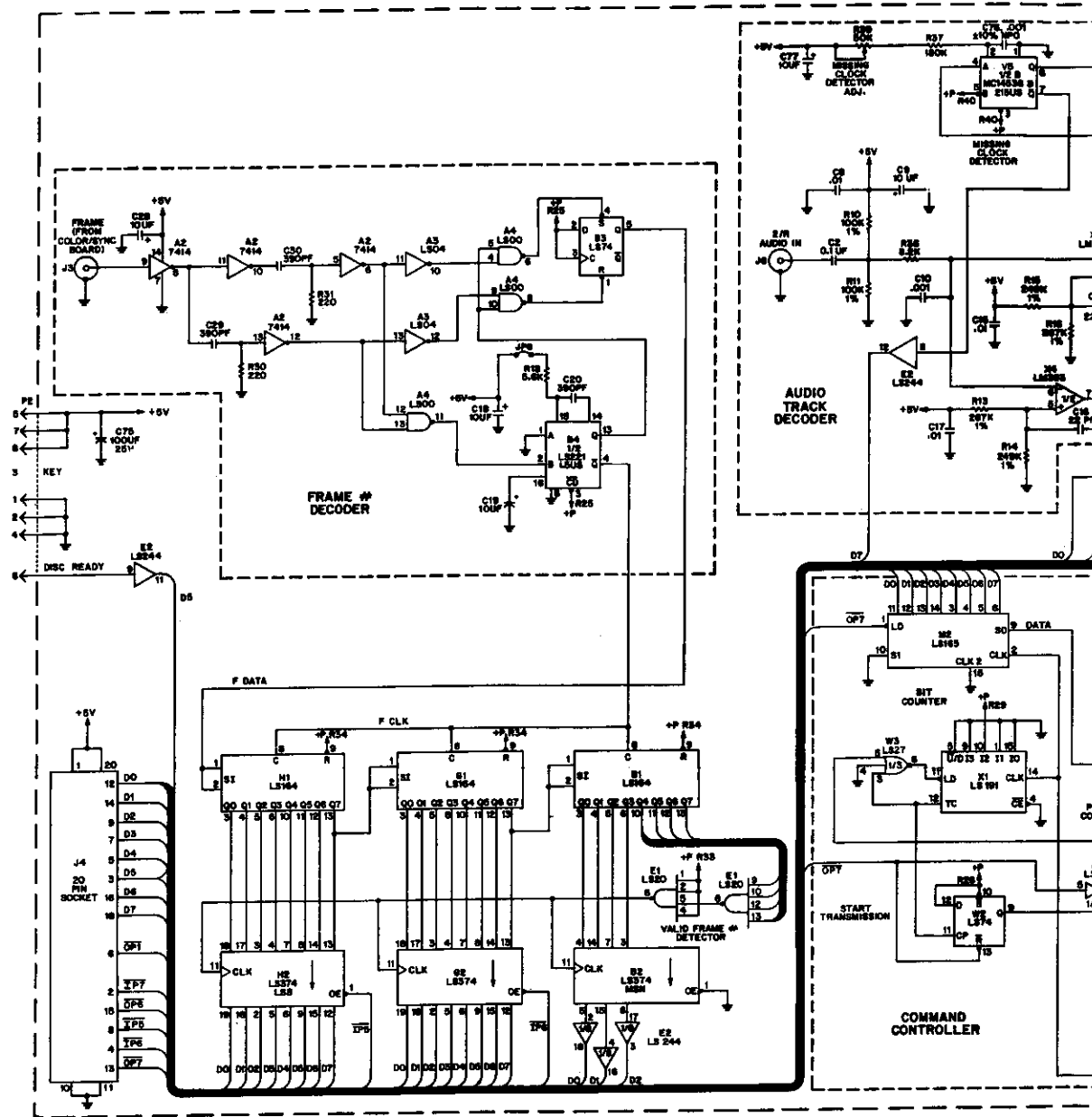

X. WIRING AND SCHEMATIC DIAGRAMS, PARTS LISTS

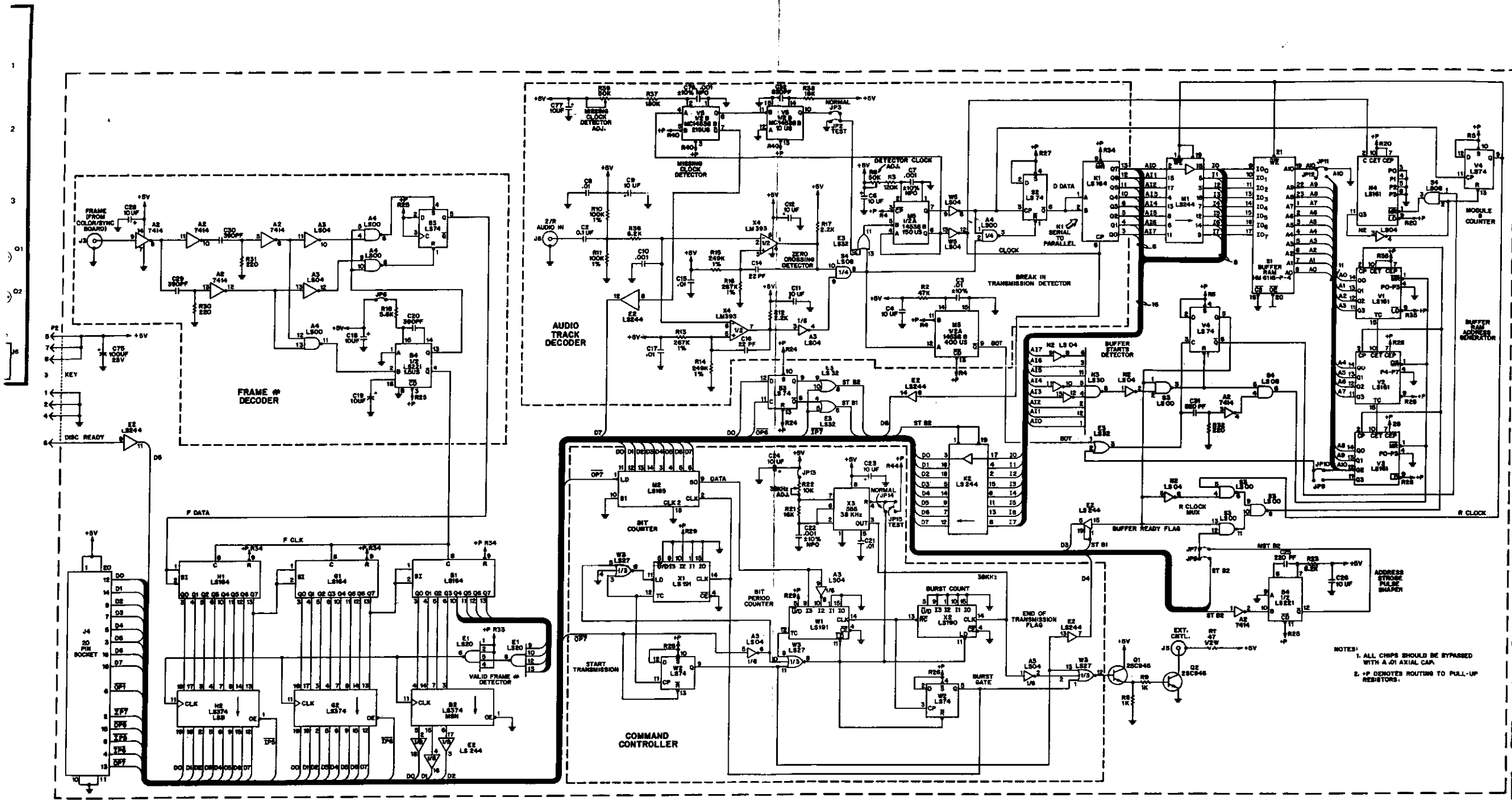

INTERFACE BOARD ASSY. (A2), SCHEMATIC DIAGRAM

NOTES:
 1. ALL CHIPS SHOULD BE BYPASS WITH A .01 AXIAL CAP.
 2. *P DENOTES ROUTING TO PULL-UP RESISTORS.

X. WIRING AND SCHEMATIC DIAGRAMS, PARTS LISTS COLOR/SYNC BOARD ASSY. (A18), COMPONENT LOCATION

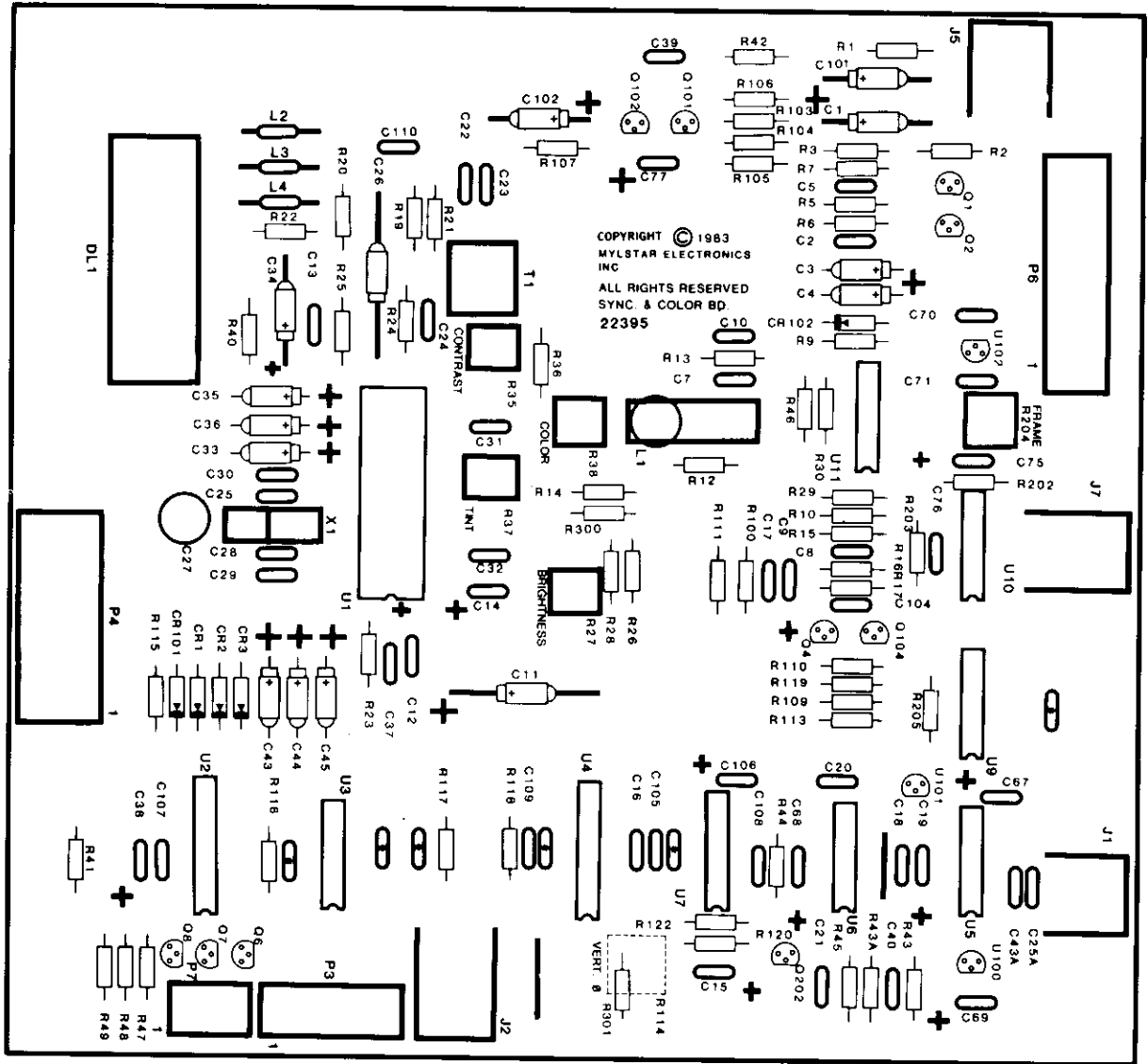

COLOR/SYNC BOARD ASSY. (A18), PARTS LIST

REFERENCE	DESCRIPTION	PART NO.	REFERENCE	DESCRIPTION	PART NO.	REFERENCE	DESCRIPTION	PART NO.
C1, C3, C9, C38, C101, C102	Color/Sync Board Assy. Capacitor, 10UF, 16V TANT-AX	MA-497 XO-749	CR1, CR2, CR3, CR101, CR102	Diode, 1N4148	XO-261	R27, R35, R37, R38	Potentiometer, 10K OHM, 5% 1/4W	XO-674
C2, CB, C12, C17, C18, C20, C24, C31, C40, C76, C104, C105	Capacitor, .01UF, 50V AX-CR, +80%-20%	XO-229	DL1	Delay Line, 400NS	XO-654	R28	Resistor, 20K OHM, 5% 1/4W	XO-41
C4, C14, C43-C45, C67, C69, C75, C77, C106	Capacitor, 1UF, 16V TANT-AX, 20%	XO-753	J1, J2	Phono Jack, Right Angle	XO-618	R43, R43A, R44, R109	Resistor, 820 OHM, 5% 1/4W Resistor, 300 OHM, 5% 1/4W	XO-174 XO-671
C5, C25	Capacitor, 39PF, 50V CM-AX	XO-334	J5, J7			R45	Resistor, 1.2K OHM, 5% 1/4W	XO-175
C7, C10	Capacitor, 560PF, 50V CM-AX, 10%	XO-681	L1	RF Choke, 8.5 MH	XO-659	R47, R48, R49	Resistor, 180 OHM, 5% 1/4W	XO-24
C11	Capacitor, 100UF, 16V ELEC-AX	XO-755	L2	Inductor, 27UH, 10%	XO-658	R106	Resistor, 560 OHM, 5% 1/4W	XO-36
C13, C21	Capacitor, .22UF, 50V CM-AX, 20%	XO-688	L3	Inductor, 47UH, 10%	XO-657	R107	Resistor, 3.9K OHM, 5% 1/4W	XO-39
C15, C19, C68, C108	Capacitor, 10UF, 10V TANT-AX, 10%	XO-209	L4	Inductor, 68UH, 10%	XO-656	R110, R115	Resistor, 3K OHM, 5% 1/4W	XO-23
C16	Capacitor, .001UF, 50V NPO CM-AX, 10%	XO-757	P3	6 Pin Wafer Conn.	XO-373	R112, R116	Resistor, 470 OHM, 5% 1/4W	XO-35
C22	Capacitor, 120PF, 50V CM-AX, 10%	XO-682	P4	Header Conn., 26 Pin	XO-651	R117	Resistor, 240 OHM, 5% 1/4W	XO-173
C23, C29	Capacitor, 100PF, 50V CM-AX, 10%	XO-680	P6	9 Pin Wafer Conn.	XO-375	R118	Resistor, 220K OHM, 5% 1/4W	XO-594
C26	Capacitor, 10UF, 25V AX-Non Polarized	XO-750	P7	3 Pin Wafer Conn.	XO-703	R120	Resistor, 68K OHM, 5% 1/4W	XO-189
C27	Capacitor, Trimmer, 5-50PF CM	XO-653	Q1, Q2, Q6, Q7, Q8, Q101, Q102, Q104	Transistor, 2SC945, NPN	XO-316	R204	Potentiometer, 1K OHM, 10% 1/4W	XO-756
C28, C43A	Capacitor, 22PF, 50V CM-AX, 10%	XO-683	Q4	Transistor, 2N3906, PNP	XO-588	R300	Resistor, 150 OHM, 5% 1/4W	XO-574
C30	Capacitor, 390PF, 50V CM-AX, 10%	XO-684	Q202	Transistor, MPS-A13, NPN	XO-304	R301	Resistor, 15K OHM, 5% 1/4W	XO-22
C32	Capacitor, 15PF, 50V CM-AX, 10%	XO-685	R1	Resistor, 75 OHM, 5% 1/4W	XO-667	T1	Transformer, 3.58 MHz Bandpass	XO-655
C33, C35, C36	Capacitor, 22UF, 16V TANT-AX, 20%	XO-752	R2, R5, R12, R14, R24, R41, R42, R202	Resistor, 1K OHM, 5% 1/4W	XO-5	U1	UPCI352C Chrominance and Luminance processor	XO-650
C34	Capacitor, 4.7UF, 16V TANT-AX	XO-754	R3	Resistor, 12K OHM, 5% 1/4W	XO-9	U2	MC14551 Quad 2-input multiplexor	XO-660
C37	Capacitor, 2.2UF, 16V TANT-AX, 20%	XO-751	R6, R119	Resistor, 2.7K OHM, 5% 1/4W	XO-6	U3	7407 Hex buffer/driver	XO-384
C39, C110	Capacitor, 68PF, 50V CM-AX, 10%	XO-636	R7	Resistor, 5.1K OHM, 5% 1/4W	XO-40	U4	MC14538B Monostable multivibrator	XO-564
C70, C71, C107, C109	Capacitor, 0.1UF, 50V CM-Bypass	XO-558	R9, R103, R113	Resistor, 10K OHM, 5% 1/4W	XO-18	U5	MC4024 Dual voltage controlled multivibrator	XO-446
			R13	Resistor, 22K OHM, 5% 1/4W	XO-42	U6	MC4044 Phase-frequency detector	XO-447
			R15, R100	Resistor, 4.7K OHM, 5% 1/4W	XO-7	U7	74LS221 Dual Monostable multivibrator	XO-666
			R16, R104	Resistor, 27K OHM, 5% 1/4W	XO-11	U9	74LS74 Dual D-type flip flop	XO-434
			R17	Resistor, 680K OHM, 5% 1/4W	XO-669	U10	75107A Dual line receivers/drivers	XO-664
			R19	Resistor, 330 OHM, 5% 1/4W	XO-34	U11	7404 Hex inverter	XO-402
			R20, R105	Resistor, 15K OHM, 5% 1/4W	XO-20	U100, U101	78L05 Positive 5VDC regulator	XO-662
			R21	Resistor, 4.7 OHM, 5% 1/4W	XO-27	XI	79L05 Negative 5VDC regulator	XO-661
			R22, R122, R205	Resistor, 2.2K OHM, 5% 1/4W	XO-47		Crystal, 3.579 MHz	XO-456
			R23	Resistor, 300K OHM, 5% 1/4W	XO-19		28 Pin DIP Socket	XO-536
			R25	Resistor, 330K OHM, 5% 1/4W				
			R26, R36	Resistor, 5.6K OHM, 5% 1/4W				

X. WIRING AND SCHEMATIC DIAGRAMS, PARTS LISTS

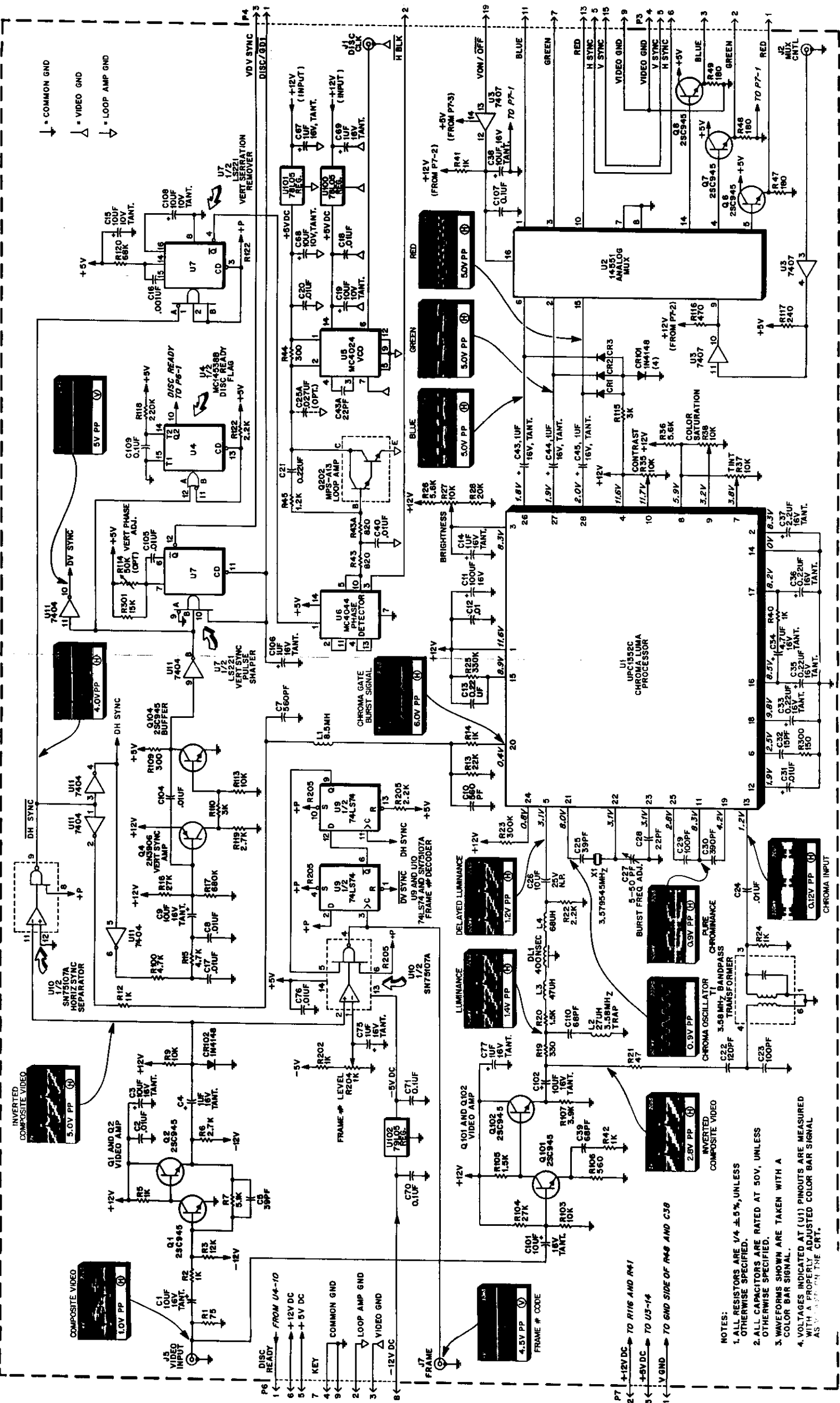

COLOR/SYNC BOARD ASSY. (A18), SCHEMATIC DIAGRAM

- NOTES:
1. ALL RESISTORS ARE 1/4 ±.5%, UNLESS OTHERWISE SPECIFIED.
 2. ALL CAPACITORS ARE RATED AT 50V, UNLESS OTHERWISE SPECIFIED.
 3. WAVEFORMS SHOWN ARE TAKEN WITH A COLOR BAR SIGNAL.
 4. VOLTAGES INDICATED AT (U1) PINS ARE MEASURED WITH A PROPERLY ADJUSTED COLOR BAR SIGNAL AS VIEWED FROM THE CRT.

PT 2 ← +12V DC TO R116 AND R41
 3 ← +8V DC TO U3-14
 1 ← V GND TO GND SIDE OF R49 AND C39

P6 1 ← DISC READY FROM U4-10
 6 ← +12V DC
 5 ← +5V DC
 7 ← KEY
 4 ← COMMON GND
 9 ← LOOP AMP GND
 2 ← VIDEO GND
 3 ← -12V DC

↓ = COMMON GND
 ∇ = VIDEO GND
 ↓ = LOOP AMP GND

X. WIRING AND SCHEMATIC DIAGRAMS, PARTS LISTS

SOUND BOARD (A6) COMPONENT LOCATION

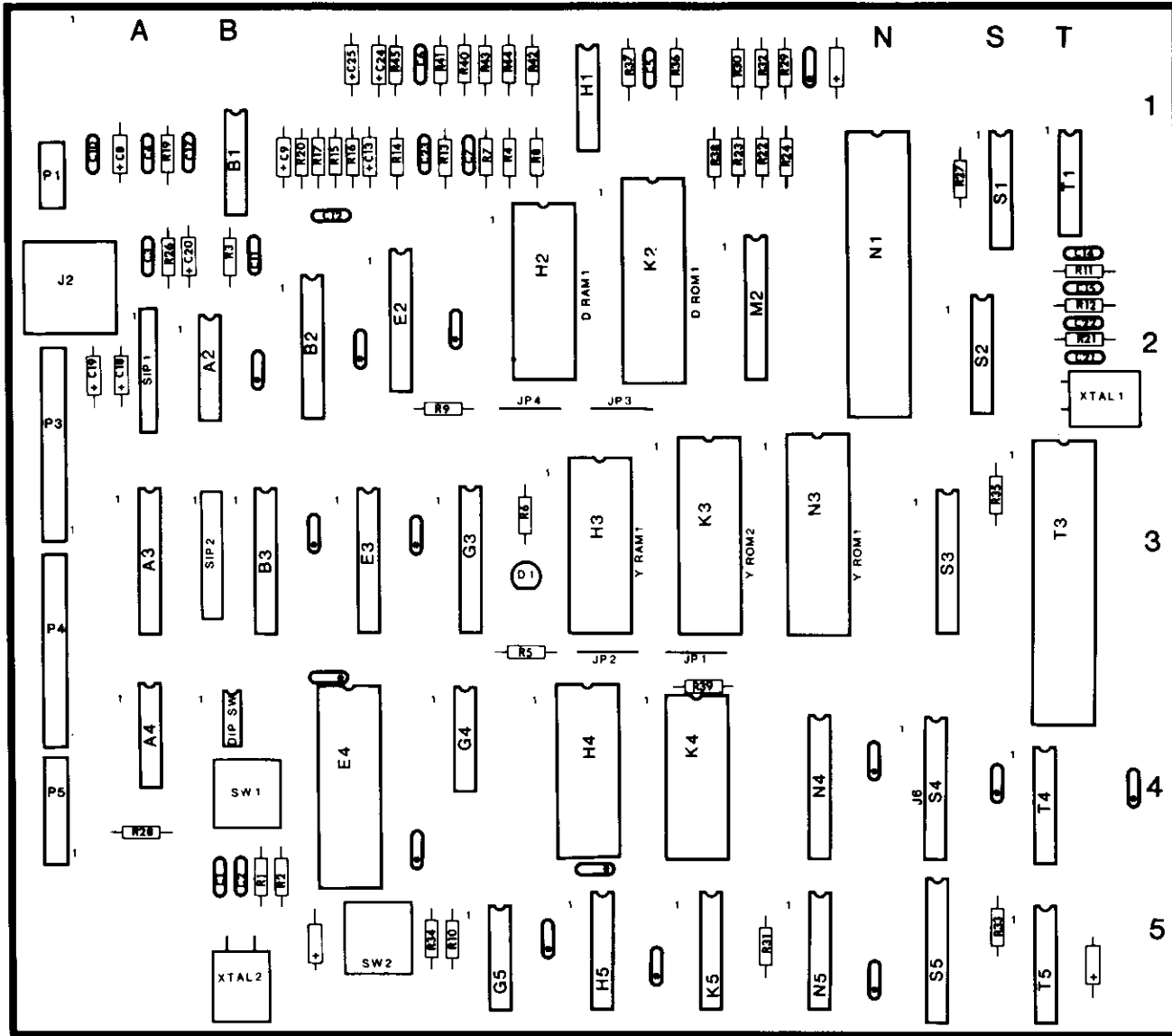

SOUND BOARD (A6) PARTS LIST

REFERENCE	DESCRIPTION	PART NO.	REFERENCE	DESCRIPTION	PART NO.
C1, C2	Sound Board Assy.	MA-495	R6	Resistor, 240 OHM, 5% 1/4W	XO-173
	Capacitor, 22PF, 50V MONO AX-CM, 10%	XO-633	R11, R12	Resistor, 470 OHM, 5% 1/4W	XO-35
C3, C21	Capacitor, 0.1UF, 50V MONO AX-GL	XO-637	R14	Resistor, 6.8K OHM, 5% 1/4W	XO-8
C5, C6	Capacitor, 01UF, 50V MONO AX-GL, 10%	XO-747	R15, R20	Resistor, 1.2K OHM, 5% 1/4W	XO-175
C7, C17, C23	Capacitor, 1UF, 50V CM-RD Non-Polarized	XO-294	R16, R17, R19, R26, R29, R30, R32, R37, R38, R40-R44	Resistor, 10K OHM, 5% 1/4W	XO-18
C8, C9, C10, C18, C19, C24, C25	Capacitor, 10UF, 25V TANT-AX, 10%	XO-127	R36, R45	Resistor, 33K OHM, 5% 1/4W	XO-43
C11	Capacitor, 10PF, 50V AX-CM, +80%-20%	XO-635	SIP1, SIP2	Resistor Pack, 5ip, 1K OHM, 9 Pin	XO-493
C13, C20	Capacitor, 1UF, 50V TANT-AX	XO-217	SW1, SW2	Switch, Push Button, N.O.	XO-365
C14	Capacitor, 68PF, 50V MONO AX-CM, 10%	XO-636	XTAL1	Crystal, 4.0 MHz	XO-366
C15	Capacitor, 047UF, 50V MONO AX-CM, 20%	XO-638	XTAL2	Crystal, 3.12 MHz	XO-639
ALL UNMARKED CAPACITORS	0.1UF, 50V CM-AX	XO-230		24 Pin DIP Socket	XO-529
ALL UNMARKED POLARIZED CAPACITORS	10UF, 25V TANT-AX, 10%	XO-127		28 Pin DIP Socket	XO-536
D1	Diode, MV5752	XO-270		40 Pin DIP Socket	XO-530
DIP SW	DIP Switch, 4 Position, 8 Pin	XO-640	A2	7430 8-input "NAND" gate	XO-643
J2	Phone Jack	XO-744	A3, B2	74LS373 Octal D-type flip flop	XO-445
P1	3 Pin Wafer Conn.	XO-703	A4	74LS74 Dual D-type flip flop	XO-434
P3, P4	9 Pin Wafer Conn.	XO-375	B1, H1	LM324 Quad op-amp	XO-644
R1	Resistor, 10M OHM, 5% 1/4W	XO-73	B3	74LS244 Octal buffer/line driver	XO-117
R2, R5, R9, R10, R27, R28, R31, R33-R35, R39, R3, R13	Resistor, 1K OHM, 5% 1/4W	XO-5	E2	AD7528J DAC	XO-674
R4, R7, R8, R22-R24	Resistor, 68 OHM, 5% 1/4W	XO-7	E3, G3, N4, S5	74LS374 Octal D-type flip flop	XO-96
			E4	SPD250 Speech generator	XO-645
			G4, T1	74LS04 Hex inverter	XO-418
			G5	74LS08 Quad 2-input "AND" gate	XO-86
			H2, H3	4801 1K x 8 SRAM	XO-193
			H4, K4	AY-3-8913 Sound generator	XO-646
			H5, K5, N5, S1, T5	74161 Synchronous presetable binary counter	XO-192
			K2, K3, N3	2732A 4K x 8 EPROM	XO-485
			N1, T3	R6502-13 CPU	XO-360
			N2, S3	74LS245 Octal bus transceiver	XO-79
			S2	74LS139 Dual 1 of 4 decoder	XO-419
			T4	74LS138 1 of 8 decoder/demultiplexer	XO-437

X. WIRING AND SCHEMATIC DIAGRAMS, PARTS LISTS

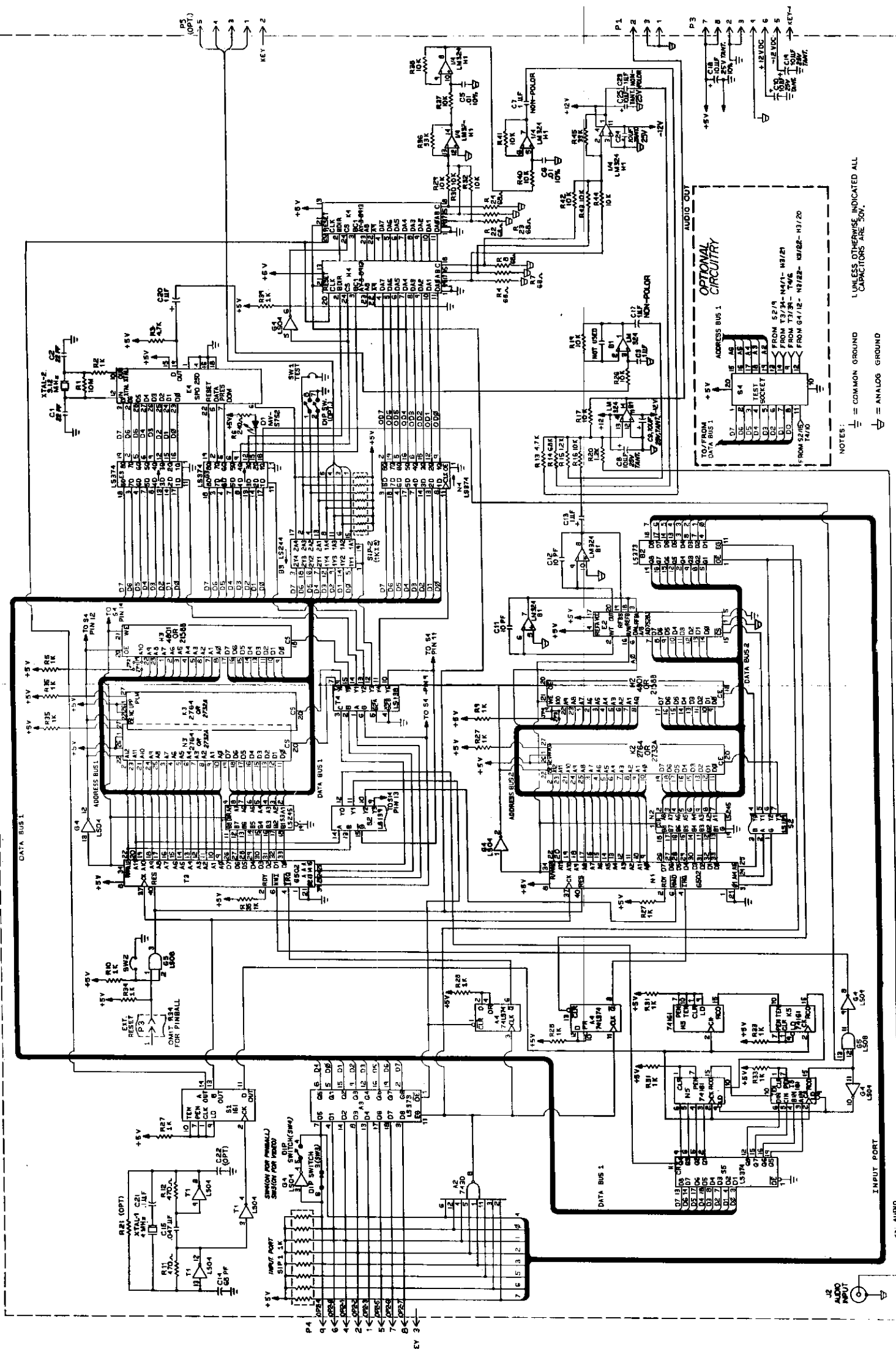

UNLESS OTHERWISE INDICATED ALL CAPACITORS ARE 50V.

NOTES:
= COMMON GROUND
= ANALOG GROUND

SOUND BOARD ASSY. (A6), SCHEMATIC DIAGRAM

X. WIRING AND SCHEMATIC DIAGRAMS, PARTS LISTS

POWER SUPPLY ASSY. (A3), COMPONENT LOCATION

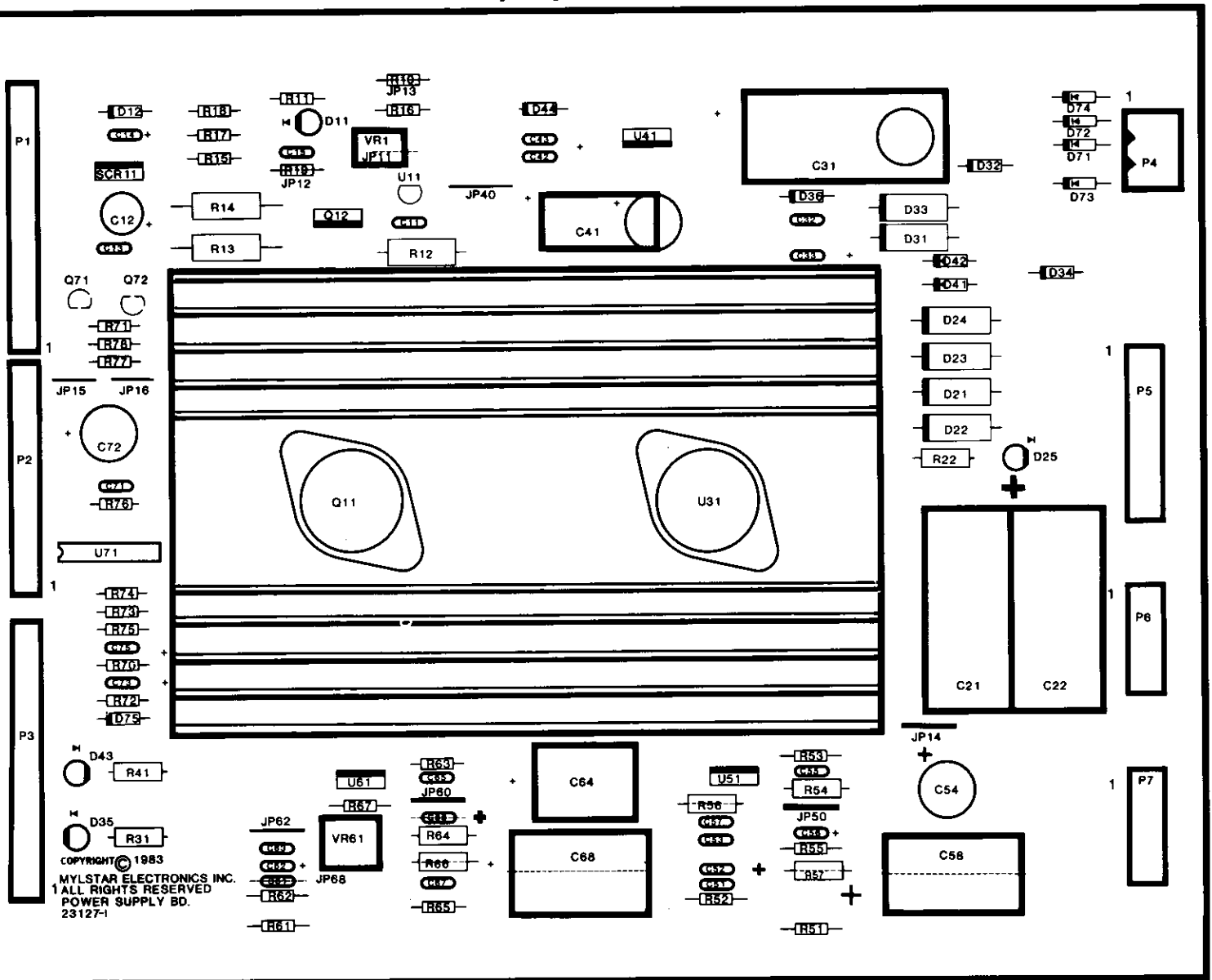

POWER SUPPLY ASSY. (A3), PARTS LIST

REFERENCE	DESCRIPTION	PART NO.	REFERENCE	DESCRIPTION	PART NO.
	Power Supply Assembly	MA-479			
C11, C32, C42, C55, C71	Capacitor, .01UF, 50V	XO-229	R12	Resistor, 100 OHM, 5%, 1W	XO-137
C12	Capacitor, 100UF, 16V	XO-235	R13, R14	Resistor, 12 OHM, 5%, 3W	XO-138
C13, C57	Capacitor, .1UF, 50V	XO-558	R15	Resistor, 200 OHM, 5%, 1/4W	XO-143
C14, C33, C43	Capacitor, .22UF, 35V	XO-615	R17, R52, R53	Resistor, 100 OHM, 5%, 1/4W	XO-28
C21	Capacitor, 2200UF, 25V	XO-346	R18	Resistor, 20 OHM, 5%, 1/4W	XO-29
C31	Capacitor, 1500UF, 35V	XO-616	R22	Resistor, 470 OHM, 5%, 1/2W	XO-55
C41, C54, C72	Capacitor, 4.70UF, 35V	XO-284	R31, R41	Resistor, 560 OHM, 5%, 1/4W	XO-36
C52, C56	Capacitor, 1UF, 35V	XO-715	R51	Resistor, 51.1K OHM, 5%, 1/4W	XO-40
C58	Capacitor, 1000UF, 25V	XO-218	R54	Resistor, 220 OHM, 5%, 1/2W	XO-185
C73, C75	Capacitor, .1UF, 35V	XO-614	R55	Resistor, 2.2 OHM, 5%, 1/4W	XO-595
D11, D25, D35, D43	Diode, Light Emitting MV-5752	XO-270	R56	Resistor, 1 OHM, 5%, 1/2W	XO-593
D12	Diode, Zener, 5.6V, 1N4734A	XO-255	R70	Resistor, 1K OHM, 5%, 1/4W	XO-5
D21-D24, D31, D33	Diode, 1N5401	XO-263	R71, R73, R77	Resistor, 10K OHM, 5%, 1/4W	XO-18
D32, D34, D36, D41, D42, D44	Diode, 1N4004	XO-254	R72	Resistor, 110K OHM, 5%, 1/4W	XO-591
D71-D75	Diode, 1N4148	XO-261	R74	Resistor, 560K OHM, 5%, 1/4W	XO-704
Q11	Transistor, PNP, 2N5879	XO-323	R75	Resistor, 2K OHM, 5%, 1/4W	XO-14
Q12	Transistor, TIP31B	XO-641	R76	Resistor, 4.7K OHM, 5%, 1/4W	XO-7
Q71	Transistor, PNP, 2N3906	XO-588	R78	Resistor, 100 OHM, 5%, 1/2W	XO-52
Q72	Transistor, NPN, 2N3904	XO-549	SCR68-1	Silicon Controlled Rectifier	XO-131
R11, R16	Resistor, 180 OHM, 5%, 1/4W	XO-24	U11	Voltage Regulator, Zener TL431	XO-272
			U31	Voltage Regulator, -12V, LM340K	XO-628
			U41	Voltage Regulator, -12V, LM320T	XO-613
			U51	Audio Amplifier, LM200T	XO-550
			U71	IC, CMOS	XO-564
			VR1	Potentiometer, 100 OHM	XO-134

X. WIRING AND SCHEMATIC DIAGRAMS, PARTS LISTS

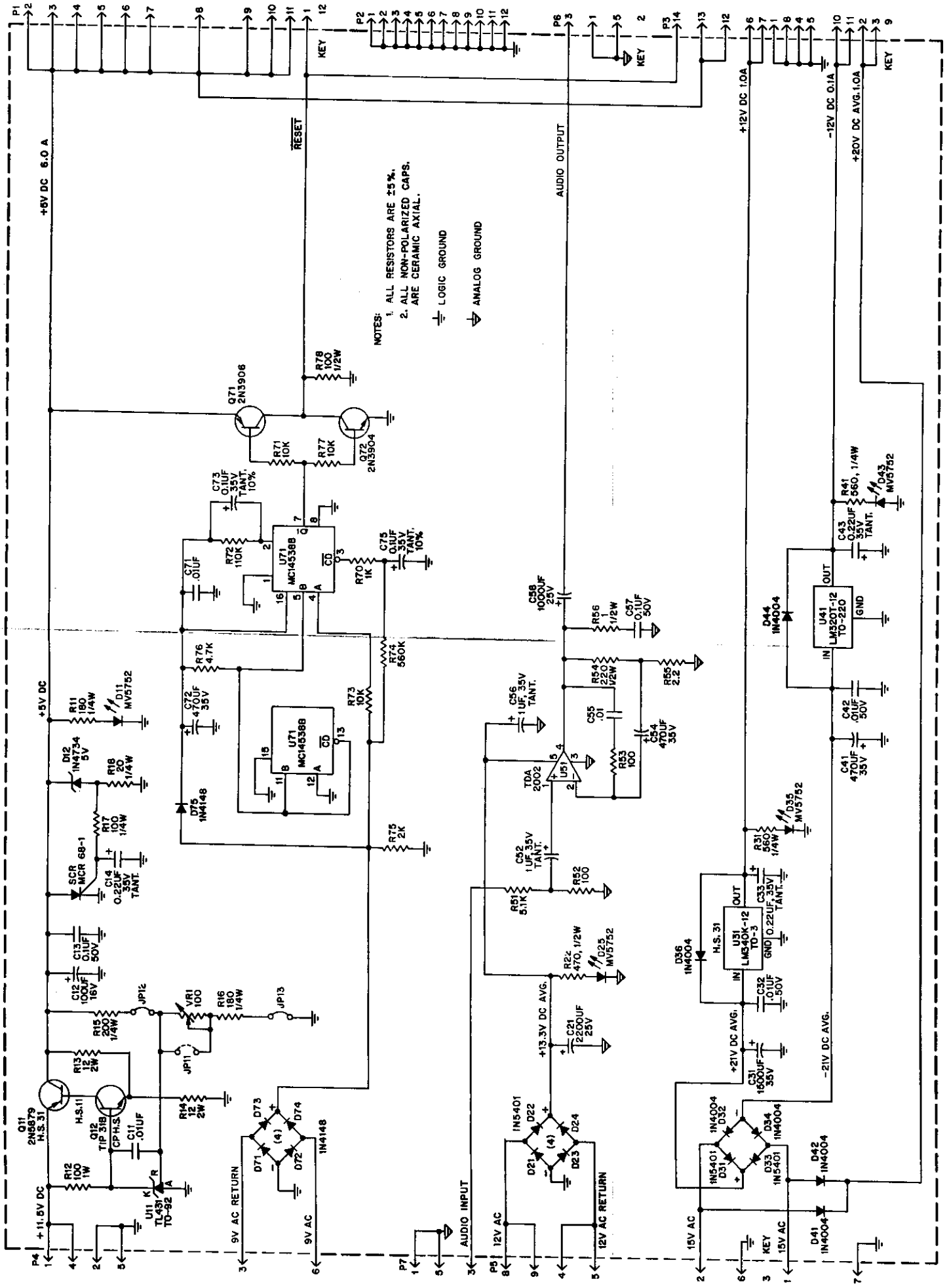

NOTES:
 1. ALL RESISTORS ARE ±5%.
 2. ALL NON-POLARIZED CAPS. ARE CERAMIC AXIAL.

⊥ LOGIC GROUND
 ≡ ANALOG GROUND

X. WIRING AND SCHEMATIC DIAGRAMS, PARTS LISTS

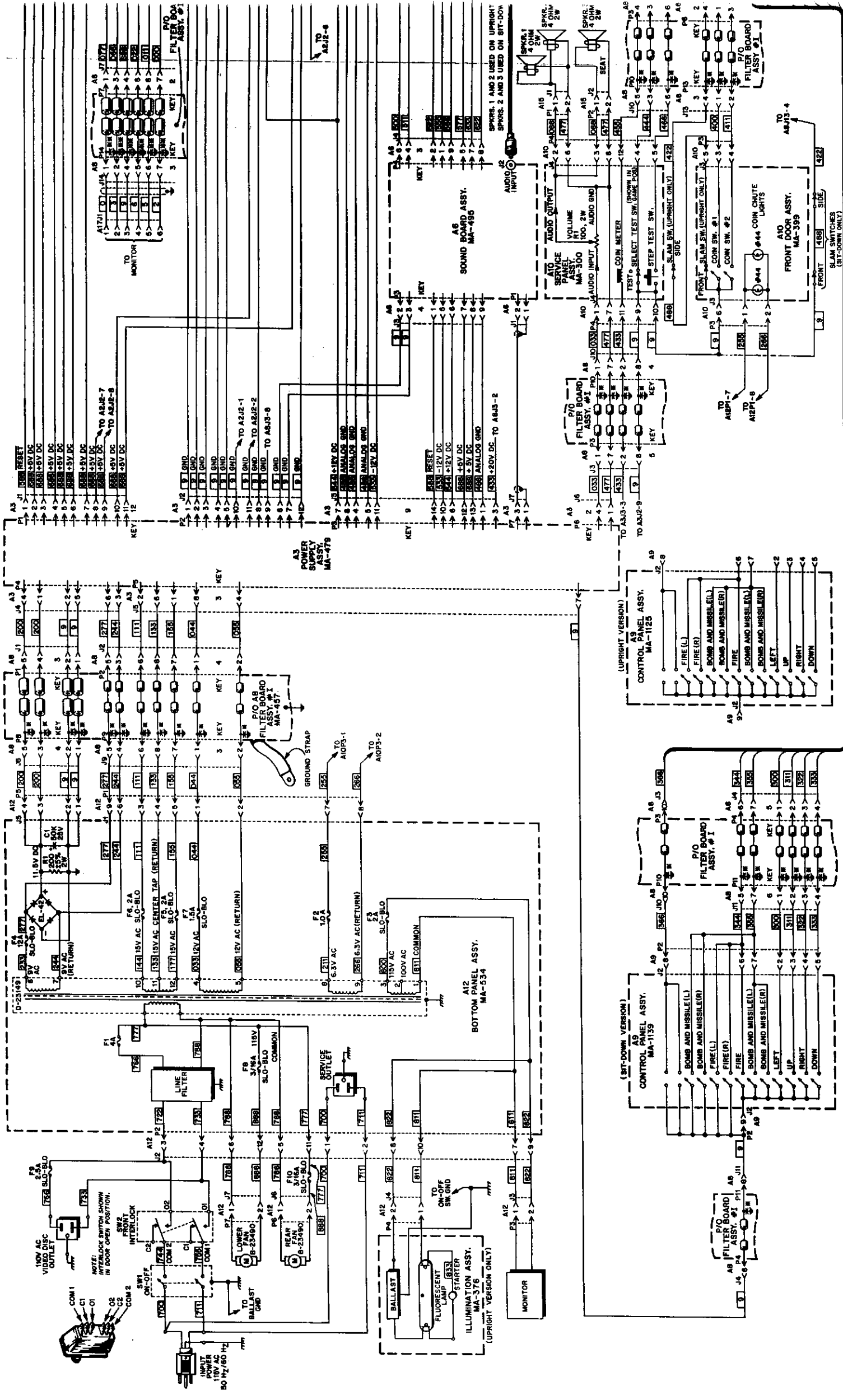

X. WIRING AND SCHEMATIC DIAGRAMS, PARTS LISTS

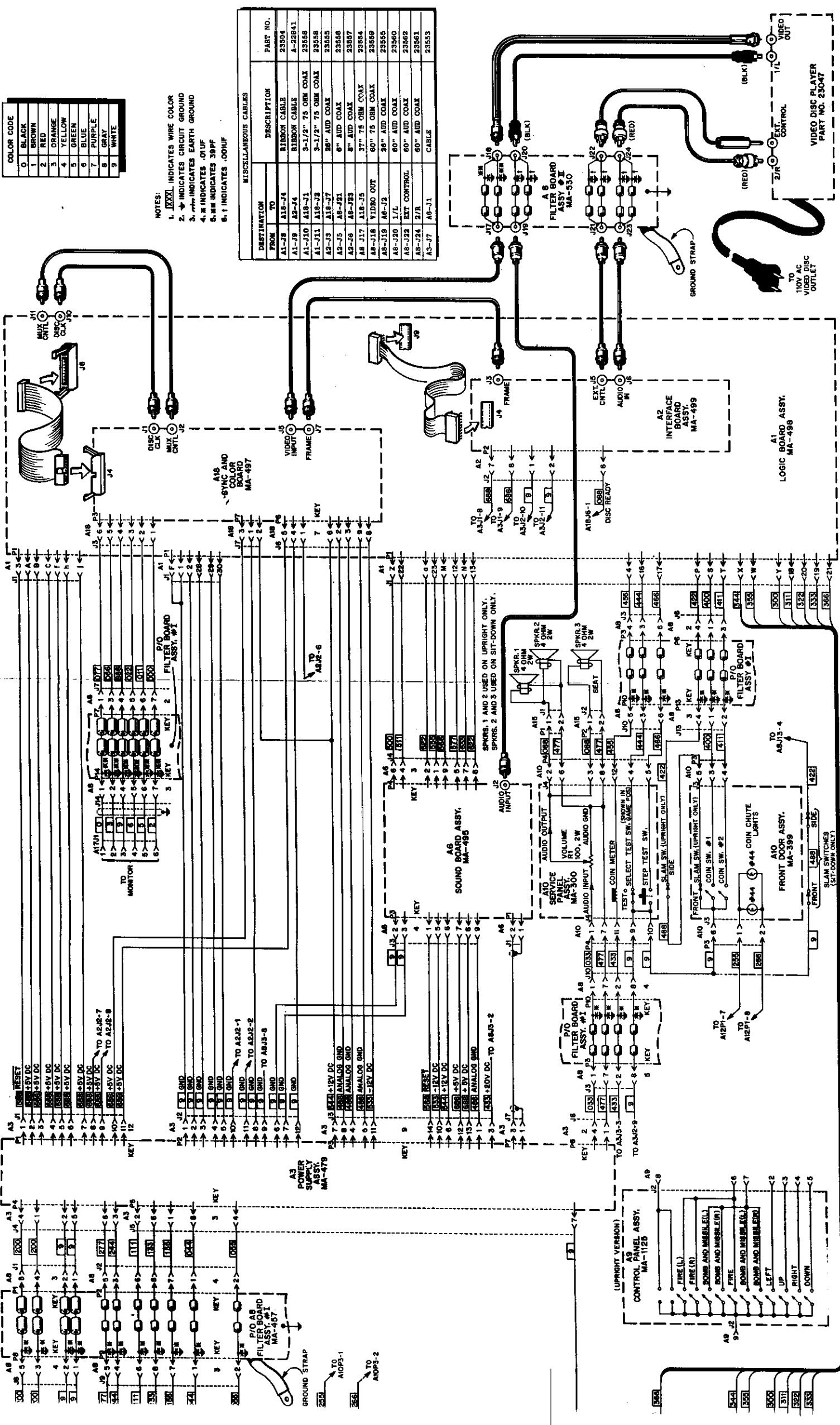

COLOR CODE	
0	BLACK
1	BROWN
2	RED
3	ORANGE
4	YELLOW
5	GREEN
6	BLUE
7	PURPLE
8	GRAY
9	WHITE

- NOTES:
1. [XXX] INDICATES WIRE COLOR
 2. * INDICATES CIRCUIT GROUND
 3. ** INDICATES EARTH GROUND
 4. # INDICATES O/U/P
 5. ## INDICATES 38P/F
 6. ! INDICATES .001U/F

DESTINATION	FROM	DESCRIPTION	PART NO.
A1-28	A16-74	RIBBON CABLE	23504
A1-29	A2-74	RIBBON CABLE	A-22841
A1-310	A18-31	3-1/2" 75 OHM COAX	23558
A1-311	A18-32	3-1/2" 75 OHM COAX	23558
A2-15	A6-121	28" AUD COAX	23555
A2-16	A6-122	8" AUD COAX	23557
A2-117	A18-15	37" 75 OHM COAX	23554
A2-118	VIDEO OUT	60" 75 OHM COAX	23559
A2-119	A6-12	60" 75 OHM COAX	23555
A2-120	1/1	60" AUD COAX	23560
A2-122	EXT CONTROL	60" AUD COAX	23562
A2-124	2/R	60" AUD COAX	23561
A2-17	A6-11	CABLE	23553

PRIMARY POWER/FILTER BOARDS/INTERCONNECTION DIAGRAM

XI. PARTS INFORMATION

TABLE OF CONTENTS (UPRIGHT VERSION), (SIT-DOWN VERSION)

	PAGE
SPEAKER/MARQUEE ASSY.	54
ILLUMINATION ASSY.	54
CONTROL PANEL ASSY.	54
SERVICE PANEL ASSY.....	54
BOTTOM PANEL ASSY.	54
CABINET PARTS (INTERIOR)	55
CABINET PARTS (EXTERIOR).....	55
FILTER BOARD I	55
FILTER BOARD II	55

XI. PARTS INFORMATION

SPEAKER/MARQUEE ASSY., ILLUMINATION ASSY.

ITEM	DESCRIPTION	PART NO.	
		UPRIGHT	SIT-DOWN
1.	Illumination Assembly	MA-554	N/A
2.	Starter	EL-69	N/A
3.	Ballast (60 Hz)	EL-70	N/A
4.	Lamp, Fluorescent	LA-4	N/A
5.	Cable Assembly (Illumination)	MA-563	N/A
6.	Cable Assembly (Speaker)	MA-318	N/A
7.	Speaker	EL-83	N/A
8.	Speaker Grill	B-20931	N/A
9.	Illumination Trim	D-23067	N/A
10.	Marquee, Lexan	23656	N/A

CONTROL PANEL ASSY.

ITEM	DESCRIPTION	PART NO.	
		UPRIGHT	SIT-DOWN
1.	Control Panel Assembly	MA-1125	MA-531
2.	Control Pod Assembly	N/A	MA-1139
3.	Lexan Overlay	A-23650	A-23488
4.	Joystick	23566	23566
5.	Control Panel Hinge	23621	23486
6.	Button, Orange	N/A	A-23502
7.	Button, Yellow	N/A	A-23510
8.	Button	A-21970	N/A
9.	Button, Holder & Switch	A-21971	A-23503
10.	Button Nuts	A-21972	A-21972
11.	Cable Assembly	MA-560	MA-555

SERVICE PANEL ASSY.

ITEM	DESCRIPTION	PART NO.	
		UPRIGHT	SIT-DOWN
1.	Service Panel Assembly	MA-550	MA-300
2.	Coin Meter	EL-84	EL-84
3.	Volume Control	XO-199	XO-199
4.	Switch (Push Button)	EL-57	EL-57
5.	Switch (Toggle)	A-23506	EL-85
6.	Cable Assembly	MA-559	MA-539

BOTTOM PANEL ASSY.

ITEM	DESCRIPTION	PART NO.	
		UPRIGHT	SIT-DOWN
1.	Bottom Panel Assembly	MA-534	MA-534
2.	Transformer	D-23149	D-23149
3.	Capacitor, 50,000 UF, 25V	XO-342	XO-342
4.	Resistor, 200 OHM, 5%, 2W	XO-142	XO-142
5.	Bridge Rectifier	EL-42	EL-42
6.	Fuse, 1½ AMP, SLO-BLO	EL-34	EL-34
7.	Fuse, 2 AMP, SLO-BLO	EL-7	EL-7
8.	Fuse, 12 AMP	FSI-83	FSI-83
9.	Fuse, 4 AMP, SLO-BLO	EL-33	EL-33
10.	Fuse, 1 AMP, SLO-BLO	EL-6	EL-6
11.	Fuse, ¾ AMP, SLO-BLO	EL-37	EL-37
12.	Service Outlet	A-18133	A-18133
13.	Line Filter	EL-50	EL-50
14.	Cable Assembly (Primary)	MA-557	MA-538
15.	Cable Assembly (Secondary)	MA-537	MA-537

XI. PARTS INFORMATION

CABINET PARTS (INTERIOR)

ITEM	DESCRIPTION	PART NO.	
		UPRIGHT	SIT-DOWN
1.	Back Door	23633	23372
2.	Interconnect Cable	MA-561	MA-543
3.	Cable Assembly, Master Electronics	MA-558	MA-544
4.	Master Electronics Board	MA-1127	MA-1159
5.	Bottom Panel Assembly	MA-534	MA-534
6.	Sound/Speech Board Assembly	MA-495	MA-495
7.	Power Supply Assembly	MA-479	MA-479
8.	Logic Board Assembly	MA-498	MA-498
9.	Color/Sync Board Assembly	MA-497	MA-497
10.	Interface Board Assembly	MA-499	MA-499
11.	Filter Board I Assembly	MA-457	MA-457
12.	Filter Board II Assembly	MA-530	MA-530
13.	Shield, Top	23619	23495
14.	Shield, Bottom	23620	23494
15.	Clamp Bracket, Shield	23634	23493
16.	Cable Assembly, High Voltage	MA-556	MA-547
17.	Cable Assembly, Monitor	A-22620	A-22620
18.	Cable Assembly, Front Door	MA-540	MA-540
19.	Cable Assembly, Fan	MA-562	MA-562
20.	Line Cord	B-23365	B-23365
21.	Cover Plate, Line Cord	A-21955	A-21955
22.	Video Disc Player	23047	23047
23.	Video Disc	23507	23507
24.	Video Disc Carton (Mailer)	23663	23663
25.	Video Disc Clamp	23688	23552
26.	Filter Assembly	23516	23516
27.	Rear Door Lock	MH-0	MH-0
28.	Anchor Plate, Lock	MH-1	MH-1
29.	Fan	B-23490	B-23490
30.	Plastic Grill	B-23307	B-23307
31.	Latch (3)	A-21969	A-21969
32.	Latch Plate (3)	A-23234	A-23234

CABINET PARTS (EXTERIOR)

ITEM	DESCRIPTION	PART NO.	
		UPRIGHT	SIT-DOWN
1.	Inside Left Decal	23658	23542
2.	Inside Right Decal	23659	23543
3.	Inside Rear Decal	23660	N/A
4.	Top Cabinet Decal	23695	23421
5.	Lexan Overlay (Screen)	23696	N/A
6.	Left Side Decal	23698	N/A
7.	Right Side Decal	23697	N/A
8.	Front Cabinet Decal	N/A	23698
9.	Upper Front Cabinet Decal	N/A	23693
10.	Top Glass	A-22464	A-23381
11.	CRT Frame	A-23657	A-23489
12.	Monitor Filter Glass	C-22849	23382
13.	Monitor Mask	D-22463	D-23513
14.	Monitor Lens	N/A	C-23305
15.	Monitor	C-21981	C-21981
16.	Window	N/A	C-23383
17.	Marquee	23656	N/A
18.	Speaker	EL-83	EL-83
19.	Speaker Grill	B-20931	B-20931
20.	Floor Mat	N/A	A-23411
21.	Interlock Switch	EL-66	EL-66
22.	Cover, Interlock Switch	A-21888	A-21888
23.	Leg Adjuster	MH-21	MH-22
24.	Caster	N/A	A-23487
25.	On-Off Switch	EL-102	EL-102
26.	Switch Plate	A-22396	A-22397
27.	Vent Channel (6)	23471	21754

FILTER BOARD I

REFERENCE	DESCRIPTION	PART NO.
	Filter Board #1 Assy.	MA-457
A8P1	6 Pin Wafer Conn.	XO-373
A8P2	9 Pin Wafer Conn.	XO-375
A8P3	10 Pin Wafer Conn.	XO-336
A8P4	8 Pin Wafer Conn.	XO-339
A8P5	7 Pin Wafer Conn.	XO-335
A8P6	4 Pin Wafer Conn.	XO-369
A8P7	7 Pin Wafer Conn.	XO-335
A8P8	6 Pin Wafer Conn.	XO-373
A8P9	9 Pin Wafer Conn.	XO-375
A8P10	10 Pin Wafer Conn.	XO-336
A8P11	8 Pin Wafer Conn.	XO-339
A8P12	7 Pin Wafer Conn.	XO-335
A8P13	4 Pin Wafer Conn.	XO-369
A8P14	7 Pin Wafer Conn.	XO-335
	Capacitor, .01UF, 50V CM-AX, +80%-20% (38 each)	XO-229
	Capacitor, 39PF, 50V CM-AX (6 each)	XO-334
	Ferrite Bead (22 each)	XO-337
	Ferrite Bead (66 each)	XO-338

FILTER BOARD II

REFERENCE	DESCRIPTION	PART NO.
	RF Filter Assembly	MA-530
	Capacitor, 39PF, 50V, CM-AX	XO-334
	Capacitor, .001UF, 50V, CM-AX	XO-695
	Ferrite Bead	XO-338
J17-J24	Jack, Phono	XO-744

NOTE: FILTER BOARDS ARE THE SAME IN BOTH VERSIONS.