

FIRE ONE
Technical Manual
November 1979

(c) EXIDY, Inc.

CONTENTS

I.	Installation.....	1
II.	Self-testing.....	2
III.	Operator Options.....	7
IV.	Player Control Adjustment.....	10
V.	Replacement Parts List.....	11
VI.	Schematics.....	13

LIST OF FIGURES

<u>Figure Number</u>	<u>Title</u>	<u>Page</u>
1	Functions of the 8-position DIP Switch	7
2	Player Control Module	9

I. INSTALLATION:

The Exidy FIRE ONE is a one unit game containing the following:

- * Video monitor module
- * Player control module
- * Mother PC board
- * Daughter PC board
- * Power supply

Before installing the game, open the back door of the unit and check the PC boards and monitor. Also check the wiring harness and make sure all the plugs are connected. To install the game, follow these steps:

1. Determine where to place the game and the direction it should face. Move the game to the location of your choice.
2. Plug the power cord into an electrical outlet. When the game is powered up it should go into the attract mode of operation.

NOTE

To put FIRE ONE into quiet attract mode, locate the 8-position DIP switch on the daughter PC board and set switch 7 to the ON position.

FIRE ONE is now in either the attract mode or quiet attract mode.

II. SELF-TESTING:

FIRE ONE has nine self tests. After FIRE ONE has been shipped and installed, it should be fully tested. To begin the self-testing do the following:

1. Unlock the back door of the unit. Remove the door by lifting it up and out.
2. Locate the 8-position DIP switch on the daughter PC board. The PC boards are on your right when you are at the back of the unit looking inside. The daughter PC board is on a shelf sticking out from the right side of the cabinet.
3. Set switch 8 to the ON position.
4. After the sign-on and copyright message appears on the screen, press the FIRE button to put FIRE ONE in the self-testing mode.

FIRE ONE is now ready for self testing. The FIRE ONE self-testing procedures are as follows:

CROSSHATCH FOCUS TEST

1. The first test which appears on the screen is a crosshatch pattern.
2. This pattern tests the color monitor for alignment and convergence.
3. Press the FIRE button to go to the next self test.

COLOR BAR TEST

1. The second test is a color bar pattern. There are eight levels each of red, blue, green and white.
2. Test and adjust the color monitor against this pattern.
3. Press the FIRE button to go to the next self test.

PLAYER CONTROL TEST

1. The third test is used to determine whether the player controls are operational and looks like this:

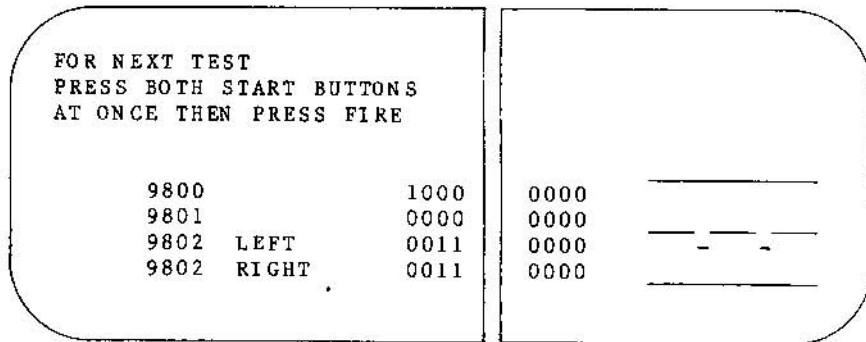

2. The last two rows of ones and zeros on the screen change as the player controls are moved. In addition the two green horizontal bars on the far right of the screen also move as the player steering controls are moved.
3. The row of ones and zeros to the right of the number 9801 tests the ONE PLAYER and TWO PLAYERS control buttons and the coin drop indicator. When the ONE PLAYER button is pressed the last digit changes from a zero to a one, indicating this control button is operational. When the TWO PLAYERS button is pushed the next to the last digit changes from a zero to a one, indicating this control button is operational. When the third digit from the right changes from a zero to a one it indicates the coin drop is operational.
4. The row of ones and zeros following "9802 RIGHT" tests the operator controls for the player on the right and "9802 LEFT" tests the operator controls for the player on the left. The first digit of each column changes from a zero to a one when the FIRE button is pressed for each. The second digit changes from zero to one when the DIVE button is pressed for each. All other digits in each row change as the STEERING shafts are moved. Move each STEERING shaft from left to right as you watch the green lines on the far right of the screen move up and down. Line up both green lines with the top, center and bottom lines on the screen. At each position check the row of ones and zeros to be sure they match each other exactly. If the rows match at each position, the STEERING operator controls are in working order.

5. Press both START buttons at once and then the FIRE button to go to the next self test.

PROGRAM MEMORY

1. The fourth test automatically does a checksum comparison on each program in ROM or PROM.
2. The screen displays a map of the daughter PC board with good PROMs shown as green bars and bad ones shown as red bars. The locations of PROMs as displayed on the screen map correspond to their location on the daughter PC board when it is in an upright, readable position.
3. Press the FIRE button to go to the next self test.

COLOR (RAM) MEMORY TEST

1. The fifth test automatically fills the screen with colorful patterns that do not have meaning. The patterns display for less than a minute while the color memory is tested.
2. After the color memory is tested the patterns are removed from the screen and a PC mother board map appears. The locations of RAMs as displayed on the screen correspond to their location on the PC mother board when it is in an upright, readable position. Good memory chips are shown as green bars and bad ones are red.
3. Press the FIRE button to go to the next self test.

MAIN RAM TEST

1. The sixth test also fills the screen with black and white patterns that do not have meaning. The patterns display for about three minutes.
2. After the RAM is fully tested a mother PC board map appears on the screen. The locations of RAMs as displayed on the screen correspond to their locations on the mother PC board when it is in an upright, readable position. Good RAMs are shown as green bars and bad ones are red.
3. Press the FIRE button to go to the next self test.

SCREEN AND SOURCE SHIFT TEST

1. The seventh test automatically checks other memory and PC board components relating to screen and source shifting and looks like this:

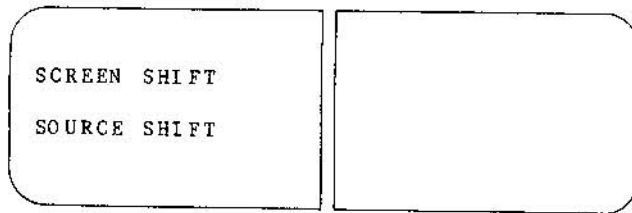

2. When an OK message appears next to a message on the screen, memory and PC board components are in working order.
3. If a NOT OK message appears next to a message on the screen, suspect chips 7A and 8A on the mother PC board (see schematic "B*W RAM ADDRESSING AND RAMS").
4. Press the FIRE button to go to the next self test.

SCREEN AND SOURCE REVERSE TEST

1. The eighth test automatically checks memory and PC board components relating to screen and source reversal and looks like this:

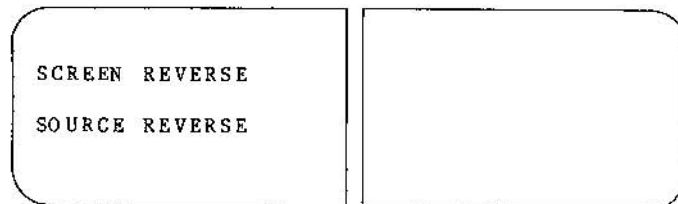

2. When an OK message appears next to a message on the screen, memory and PC board components are in working order.

3. If a NOT OK message appears next to a message on the screen, suspect chips 7A and 8A on the mother PC board (see schematic "B*W RAM ADDRESSING AND RAMS").
4. Press the FIRE button to go to the next self test.

ARITHMETIC LOGIC TEST

1. The ninth test automatically checks the arithmetic logic unit registers.
2. The screen displays a vertical stripe which looks like the MAIN SCREEN RAM test. The vertical stripe moves from left to right across the screen for about 30 seconds.
3. When an ALU OK message appears on the screen the arithmetic logic unit is in working order.
4. If an ALU NOT OK message appears on the screen, suspect ALU chips and associated input address lines (see schematic "DATA PROCESSING") and output RAM circuits (see schematic "B*W RAM ADDRESSING AND RAMS").

Now the self tests are finished. To get FIRE ONE out of the self-testing mode, find the 8-position DIP switch on the daughter PC board and set switch 8 to the OFF position. Push the FIRE button to put FIRE ONE back into the attract mode.

III. OPERATOR OPTIONS:

The AUDIO VOLUME CONTROL pots are located at 13B and 14B on the daughter PC board. With the board in the upright, readable position the pot on the right controls the volume for the player on the right and the pot on the left controls the volume for the player on the left. All the other FIRE ONE operator options are selected by setting the 8-position DIP switch on the daughter PC board. Figure 1 shows all selectable functions controlled by the 8-position DIP switch.

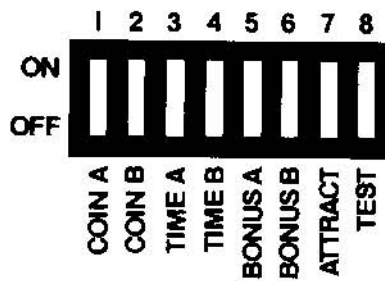

Figure 1. Functions of the 8-position DIP Switch

COINAGE

Switch 4	Switch 3	1 Player Coins	2 Players Coins	Time
OFF	OFF	1	2	75
OFF	ON	1	1	90
ON	OFF	2	2	105
ON	ON	2	4	120

BONUS DIFFICULTY

Switch 6	Switch 5	Difficulty	Ships sunk / Sub hits per Player per Minute
OFF	OFF	EASY	12
OFF	ON	AVERAGE	16
ON	OFF	TOUGH	20
ON	ON	VERY TOUGH	24

ATTRACT (Switch 7)

OFF	PLAY MUSIC DURING ATTRACT SEQUENCE
ON	NO MUSIC DURING ATTRACT SEQUENCE

TEST MODE (Switch 8)

OFF	NORMAL PLAY
ON	RUN DIAGNOSTIC AND OPERATOR ALIGNMENT TESTS

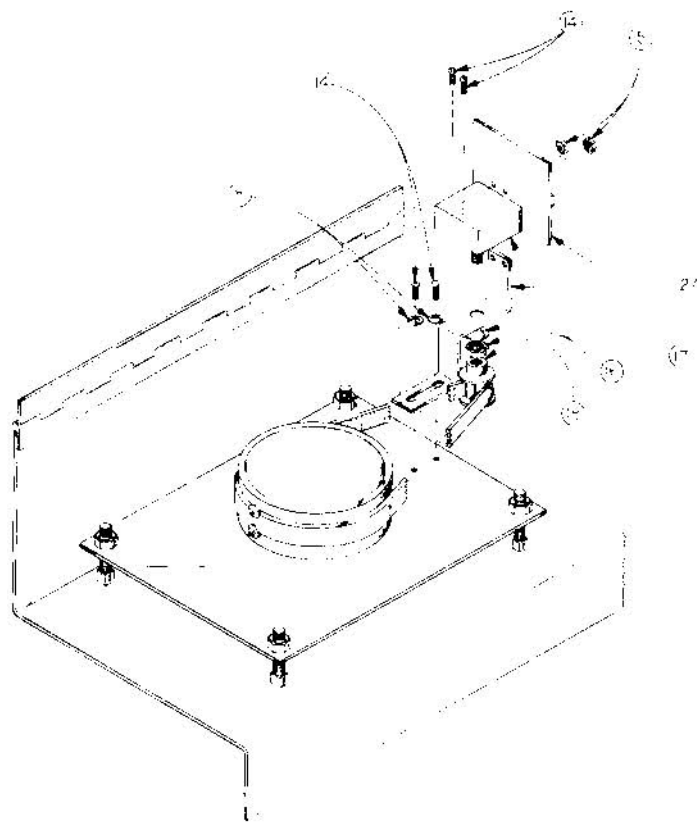

Figure 2, Player Control Module

IV. PLAYER CONTROL ADJUSTMENT:

Figure 2 shows the player control module. To adjust the player controls do the following:

1. Unlock and remove the back door of the unit by lifting it up and out.
2. From the inside of the video module, loosen the four bolts connecting the top of the player control module to the unit.
3. Go to the front of the unit and open the player control module by lifting it up and out.
4. Locate the 8-position DIP switch on the daughter PC board. Set switch 8 to the ON position.
5. Press the FIRE button three times to bring up the third diagnostic test.
6. Loosen the setscrew holding the gear belts to the tubes.
7. Set the steering control handle to the center position.
8. Pull the gear belt until the green bars are aligned with the red bar at the center of the screen.
9. Tighten the setscrews.
10. Close the player control module by lifting it up and forward.
11. Go to the back of the unit. From inside the video module, tighten the four bolts connecting the top of the player control module to the unit.
12. Set switch 8 to the OFF position and push the FIRE button to put FIRE ONE back into the attract mode.

V. REPLACEMENT PARTS LIST:

The parts list that follows describes the most important FIRE ONE parts including Exidy replacement part numbers and reference locations.

PART NUMBER	QTY	DESCRIPTION	REFERENCE LOCATION
48-2300	1	74LS00 TTL LC	7G
48-2006	1	74S02 TTL LC	1E
48-2010	1	7404 TTL LC	4G
48-2302	2	74LS04 TTL LC	1F, 3D
48-2011	1	74S04 TTL LC	2C
48-2312	3	74LS08 TTL LC	3C, 4D, 8K
48-2052	2	7411 TTL LC	4E
48-2304	1	74LS27 TTL LC	4A
48-2324	1	74LS30 TTL LC	7D
48-2222	1	74LS55 TTL LC	2J
48-2341	1	74LS86 TTL LC	5A
48-2078	1	74LS109 TTL LC	1J, 2E
48-2307	1	74LS138 TTL LC	3J
48-2321	1	74LS139 TTL LC	2D
48-2322	5	74LS135 or 25LS153 TTL LC	5B, 5C, 5D, 5E, 8L
48-2101	4	25LS153 or 74153 TTL LC	3E, 3F, 8F, 8G
48-2323	6	74LS157 TTL IC	2F, 4B, 4F, 7J, 8H, 8J
48-2349	1	74LS158 TTL IC	7B
48-2308	5	74LS161 TTL IC	1G, 1H, 2A, 2G, 2H
48-2097	1	74S163 TTL IC	1D
48-2099	1	74LS164 TTL IC	4C
48-2309	1	74LS166 TTL IC	7F
48-2107	1	74LS175 TTL IC	3A
48-2109	2	74LS181 TTL IC	8E, 8D
48-2347	2	74LS240 TTL IC	9J, 10J
48-2326	7	74LS244 TTL IC	3G, 3H, 4J, 5G, 6F, 6G, 7C
48-2348	4	74LS253 TTL IC	6B, 6C, 6D, 6E
48-2121	2	74LS257 TTL IC	5J, 6J
48-2123	1	74LS273 TTL IC	7E
48-2124	1	74276 TTL IC	2B
48-2136	1	74LS283 TTL IC	8E
48-2153	2	74S288 TTL 32x8 ROM or PROM	7A
48-2154		Tristate or open collector	8A

PART NUMBER	QTY	DESCRIPTION	REFERENCE LOCATION
48-2208	6	74LS377 TTL IC	5F, 6A, 6H, 7H, 7K, 7L
48-2344	1	82S09 or 93419 TTL 64x9 RAM	6K
48-0280	1	Z-80 MOS Microprocessor	4H
48-2211	2	LM379	IC 42, 43
48-2212	2	NE556	IC 29, 31
48-9067	3	LM558	IC 6, 16, 17
48-2221	2	3340	IC 28, 30
48-2206	3	LM3900	IC 2, 4, 14
48-2088	1	4006	IC 40
48-9069	1	4013	IC 3
48-9070	1	4017	IC 5
48-2093	1	8038	IC 15
48-9068	1	8253-5	IC 1
48-2089	1	14507 or 4070	IC 41
48-2300	1	741LS00 or 7400	IC 26
48-2300	1	74LS04 or 7404	IC 34
48-2013	1	7406 or 74LS06	IC 27
48-2315	1	74LS32	IC 39
48-2307	2	74LS138	IC 32, 33
48-2347	2	74LS240	IC 37, 38
48-2326	1	74LS244	IC 25
48-2208	2	74LS377	IC 35, 36
54-5036	2	Pot w/nut and LW	

VI . FIRE ONE SCHEMATICS;

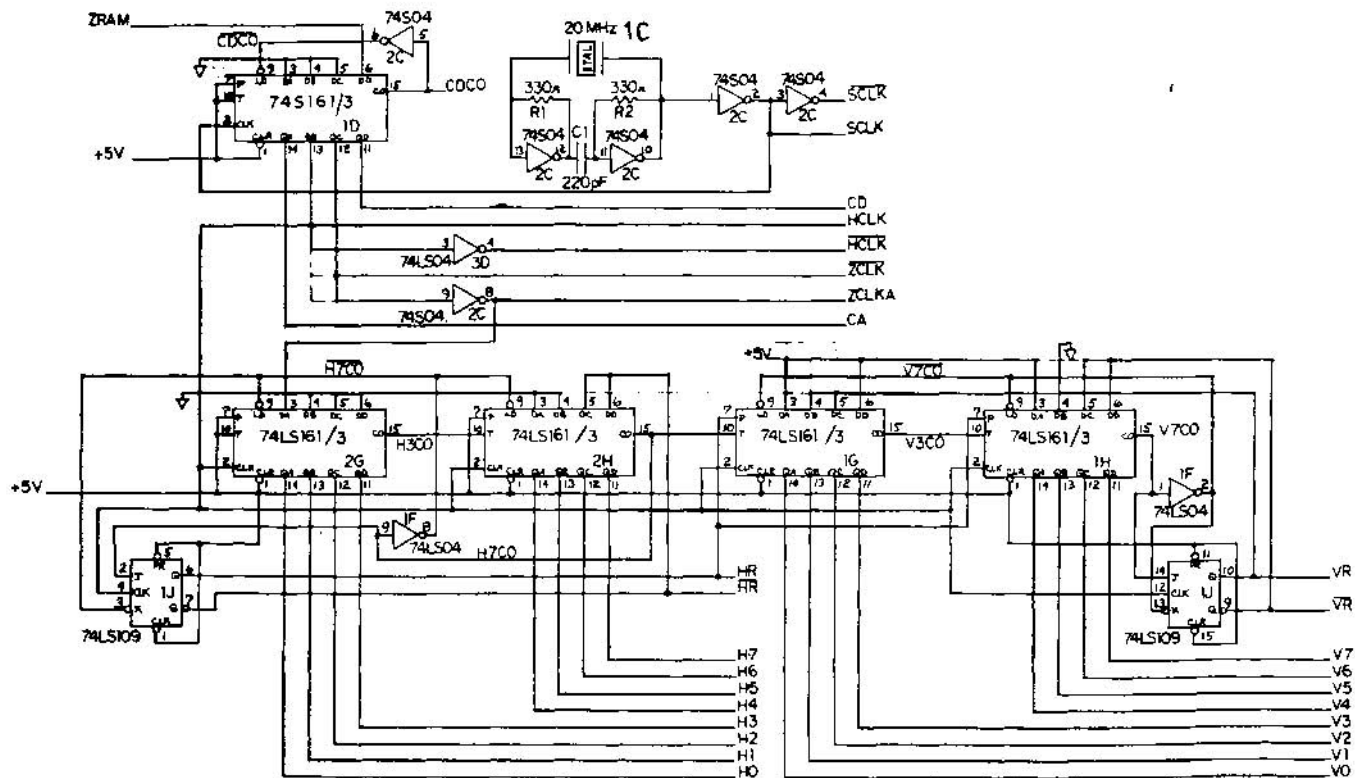

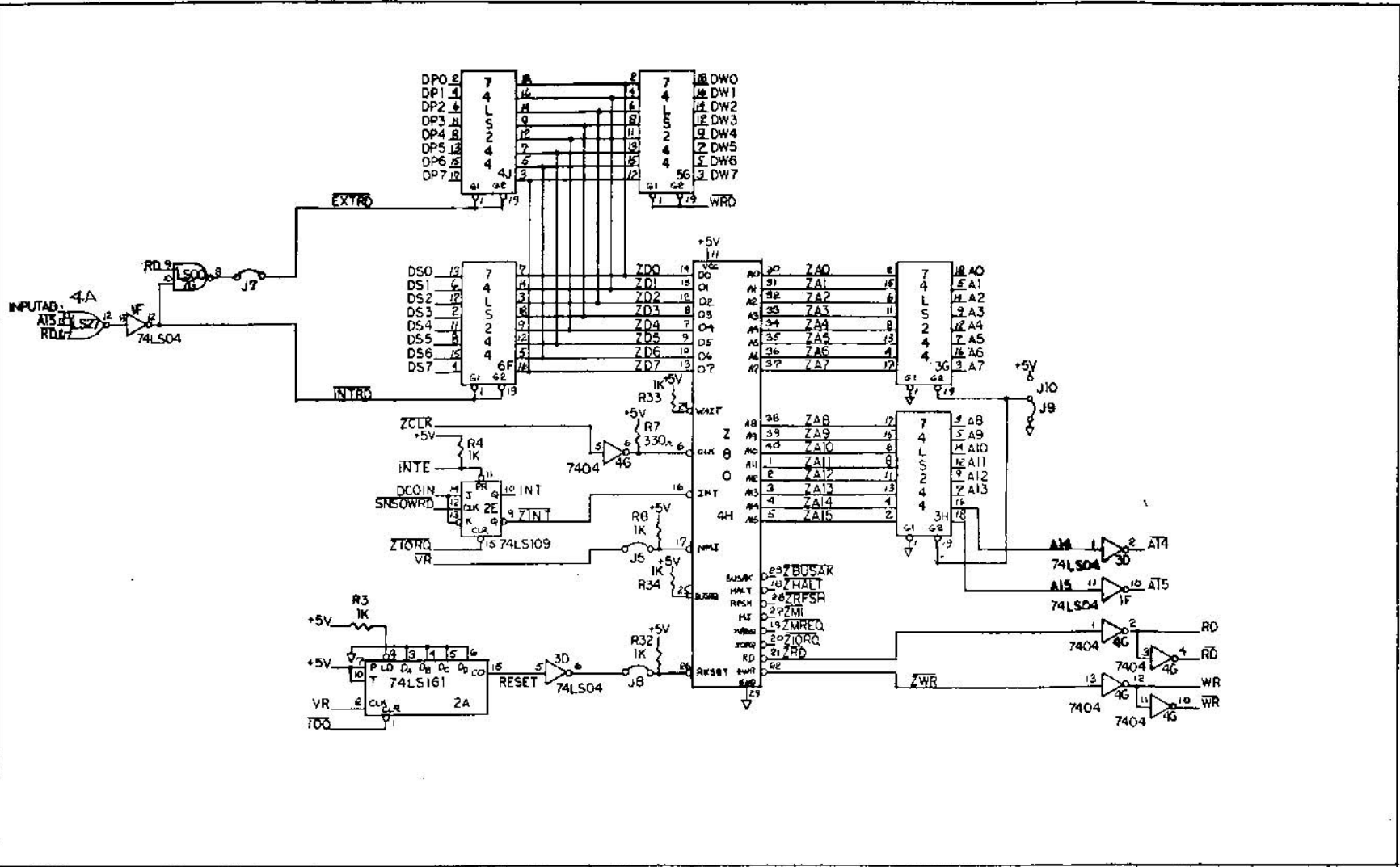

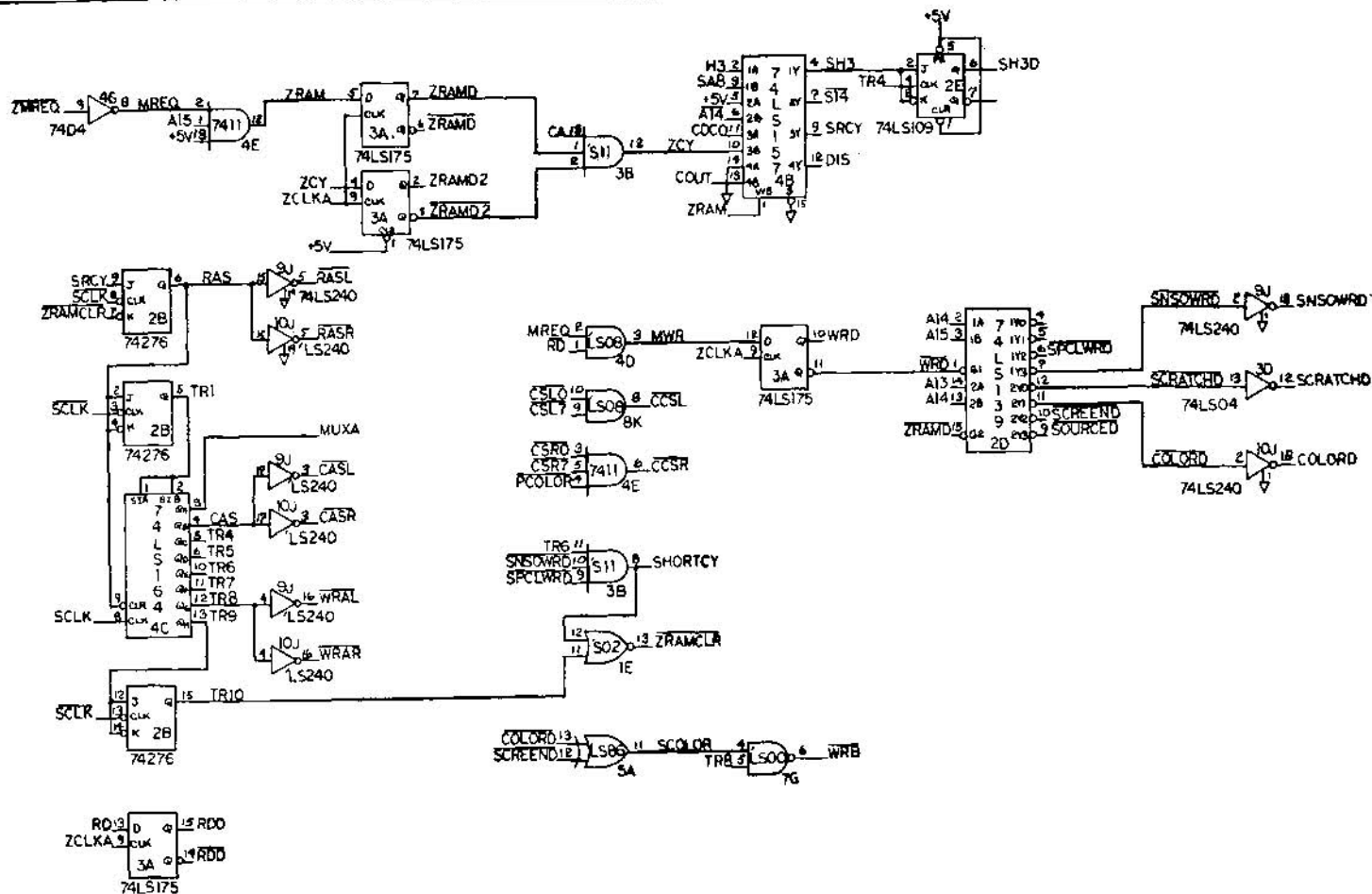

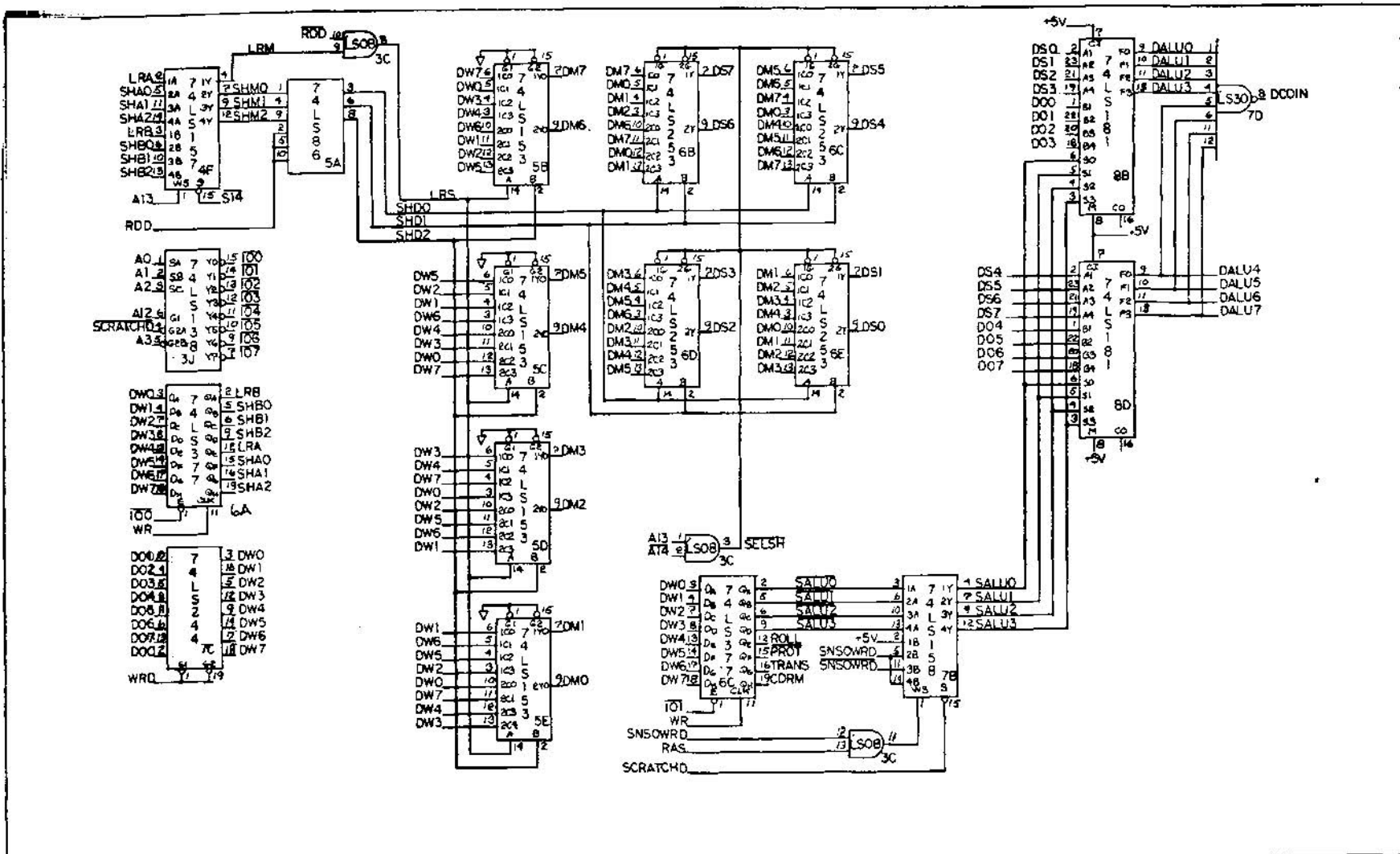

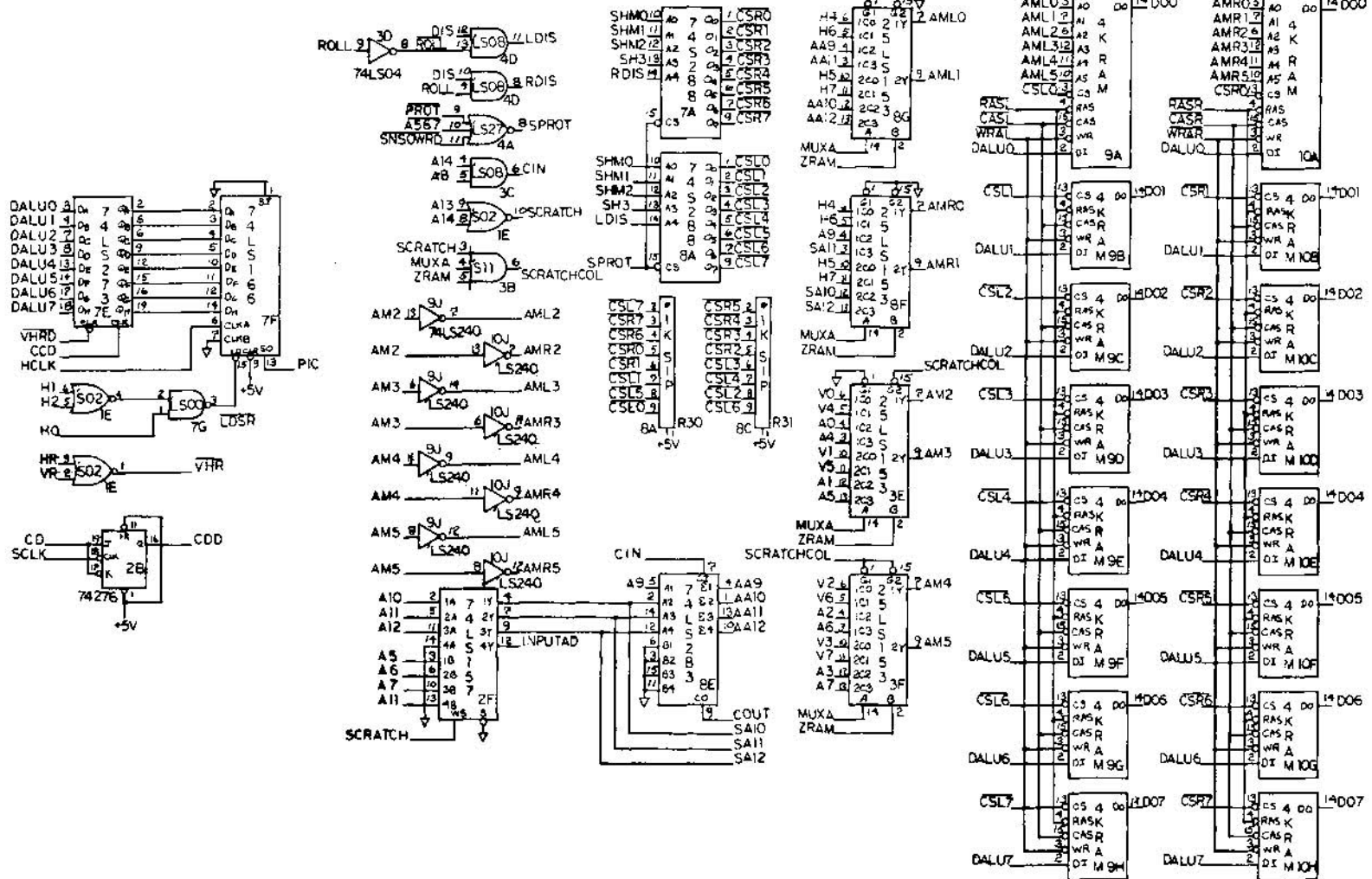

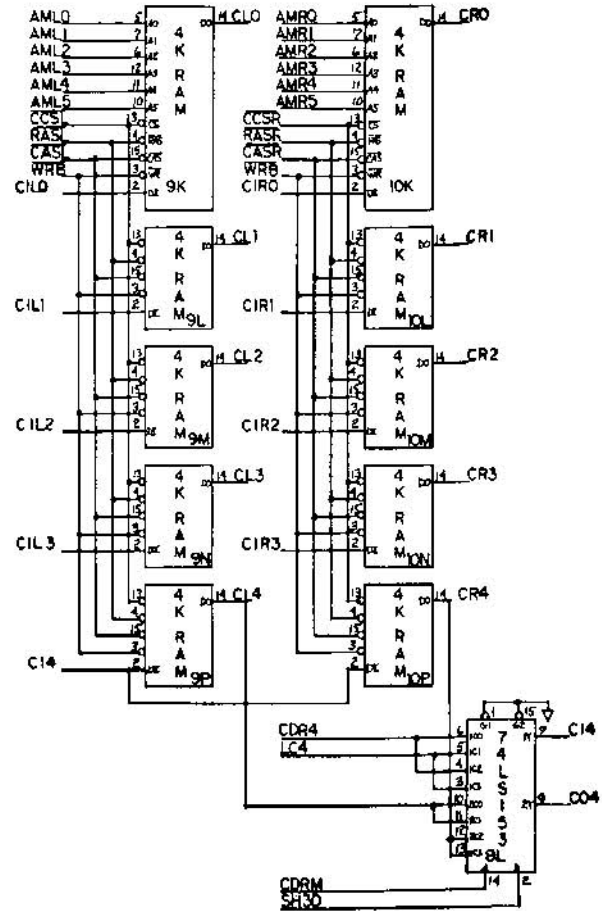
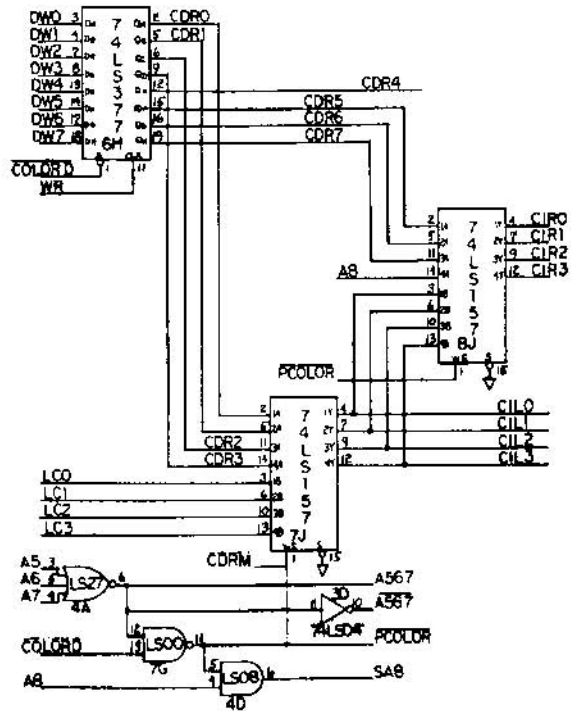

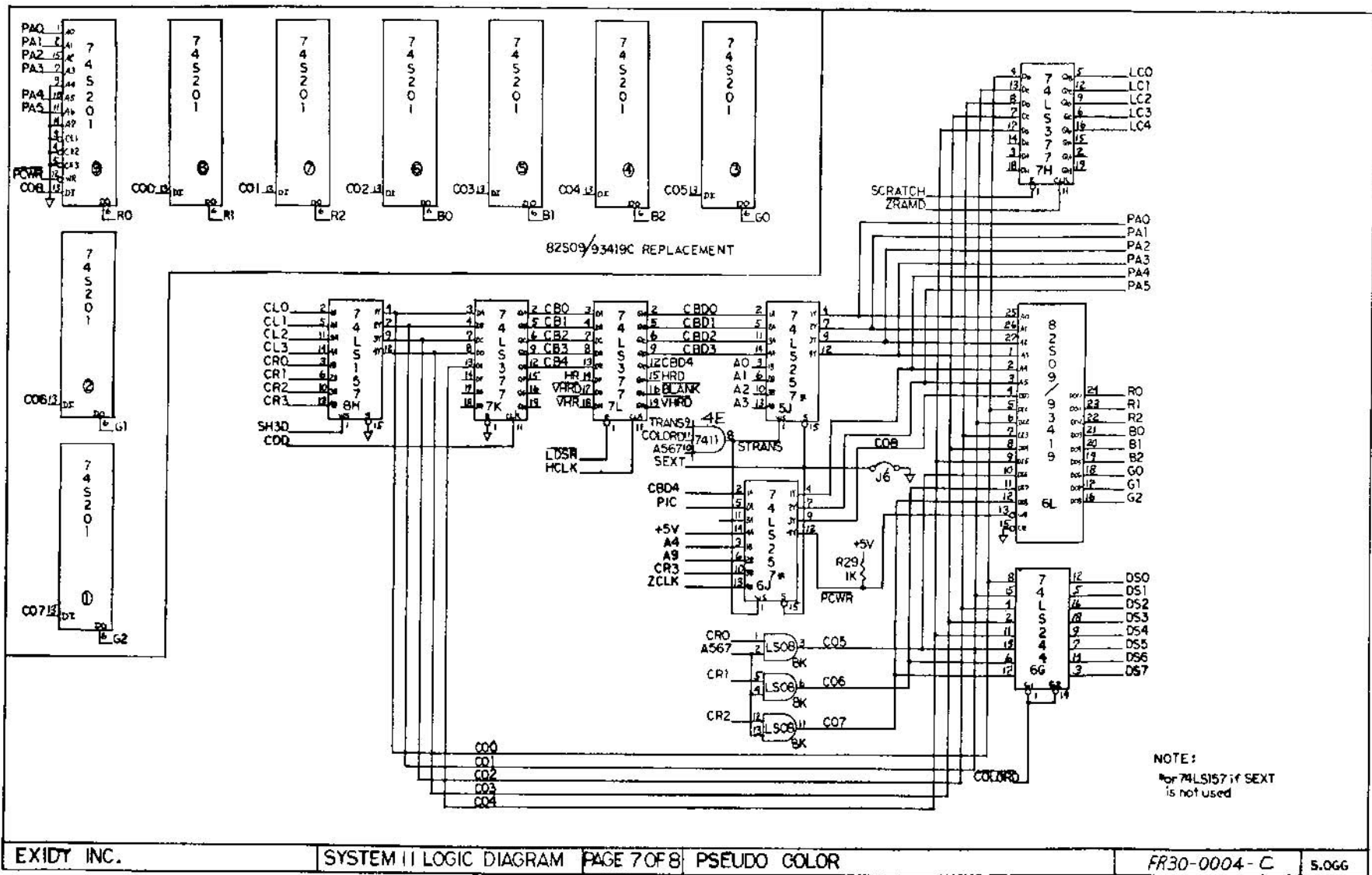

V4	1	2	Y0
V5	3	4	V1
V6	5	6	V2
V7	7	8	V3
-12V	9	10	-12V
-12V	11	12	-12V
LOSR	13	14	CA
GND	15	16	GND
GND	17	18	GND
+5V	19	20	+5V
ZCLKA	21	22	HCLK
H4	23	24	H0
H5	25	26	H1
H6	27	28	H2
H7	29	30	H3
A8	31	32	A0
A9	33	34	A1
A10	35	36	A2
A11	37	38	A3
A12	39	40	A4
A13	41	42	A5
A14	43	44	A6
A15	45	46	A7
I00	47	48	HR
I01	49	50	VR
I02	51	52	INTE
I03	53	57	SCRATCHD
I04	55	58	WR
I05	57	60	RD
I06	59	60	MREQ
I07	61	62	STRANS
GND	63	64	GND
GND	65	66	GND
+5V	67	68	+5V
DP4	69	70	DP0
DP5	71	72	DP1
DP6	73	74	DP2
DP7	75	76	DP3
+12V	77	78	-12V
+12V	79	80	-12V
-5V	81	82	-5V
-5V	83	84	-5V
DW4	85	86	DW0
DW5	87	88	DW1
DW6	89	90	DW2
DW7	91	92	DW3
PA4	93	94	PA0
PA5	95	96	PA1
PIC	97	98	PA2
SEXT	99	100	PA3

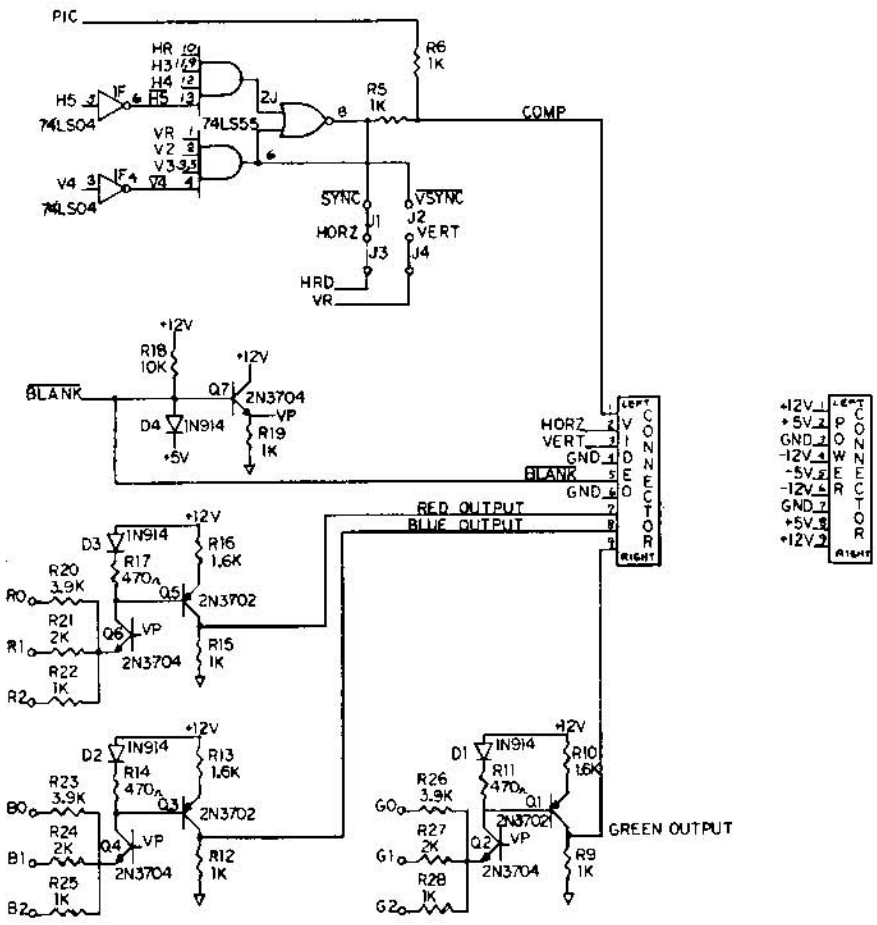

SHUNT DIP CONFIGURATIONS

only one type is used depending on memory chip type

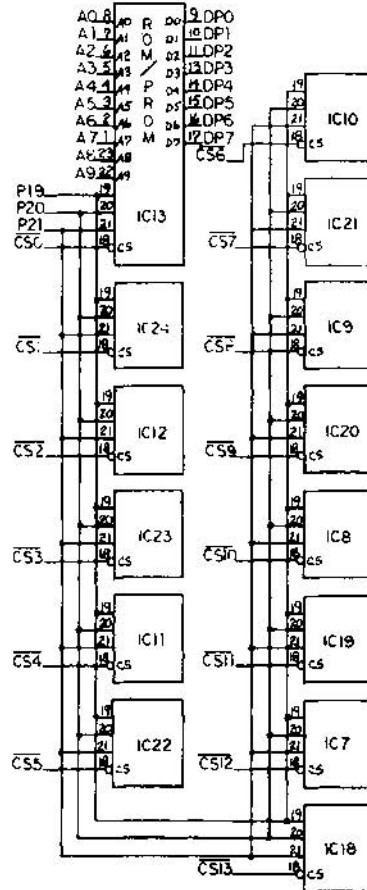
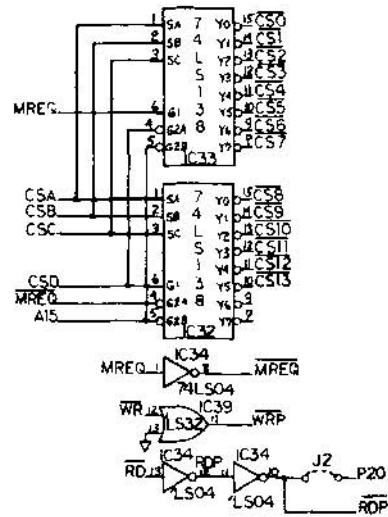
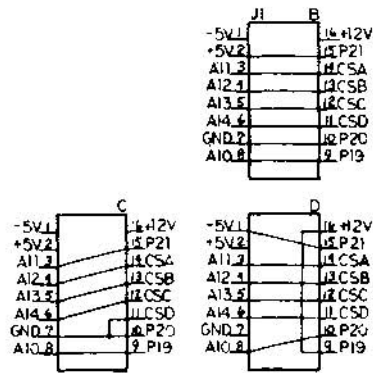

SHUNT DIPS:

TYPE	ROM or PROM
B	T.I. 8316B T.I. 2516 Intel 2716 Intel 2316E Rockwell 2316B
C	Intel 2732 Intel 2332 T.I. 2532
D	T.I. 2716

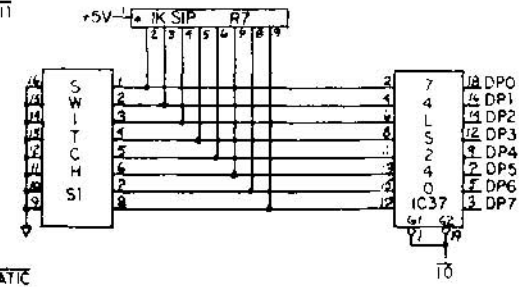
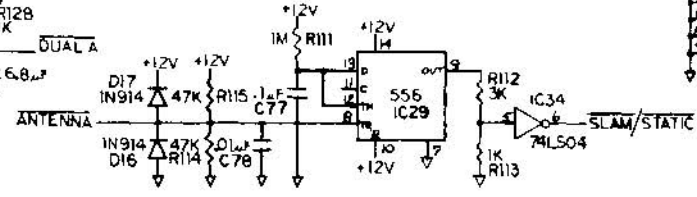
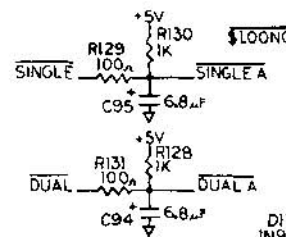
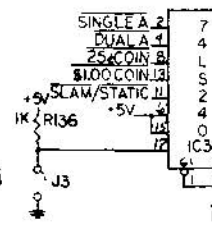
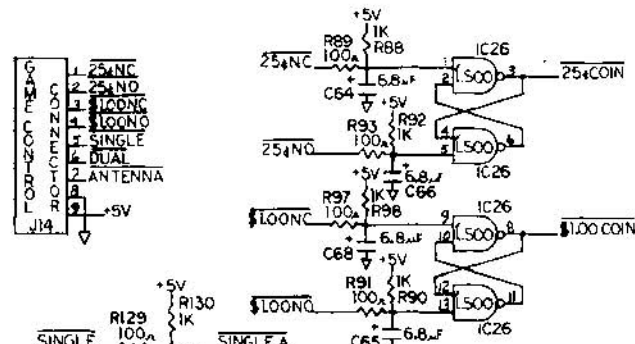
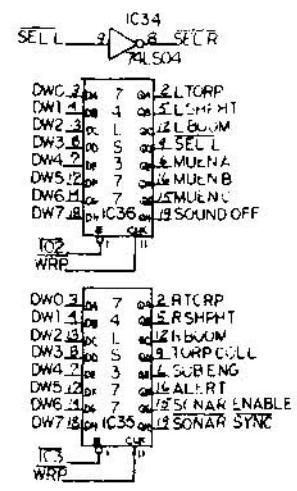
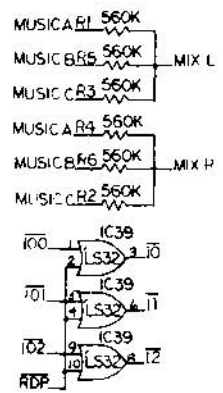
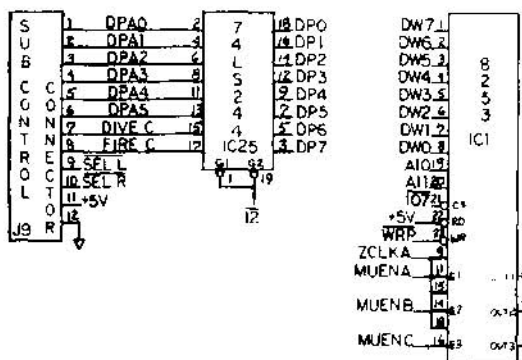

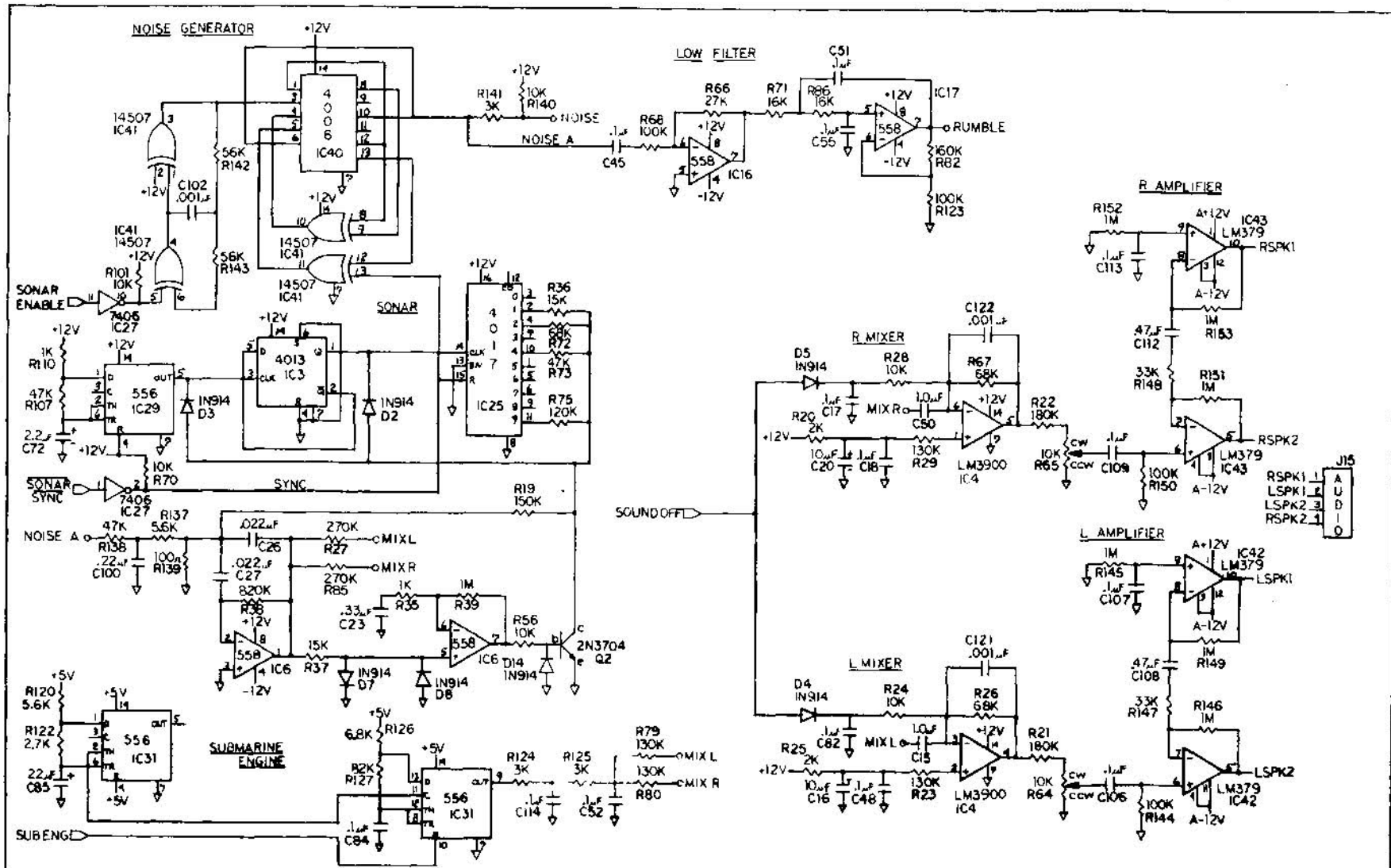

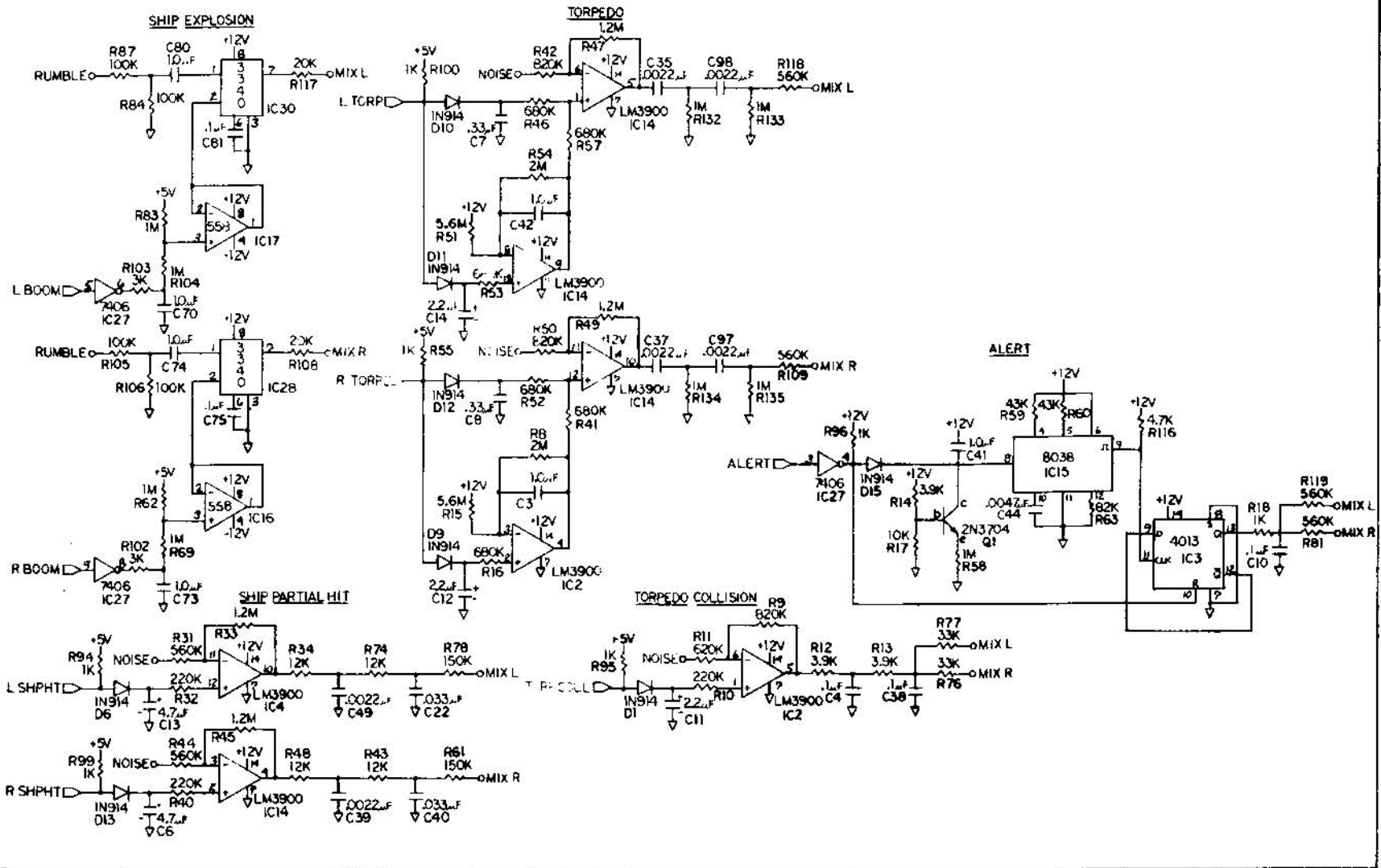

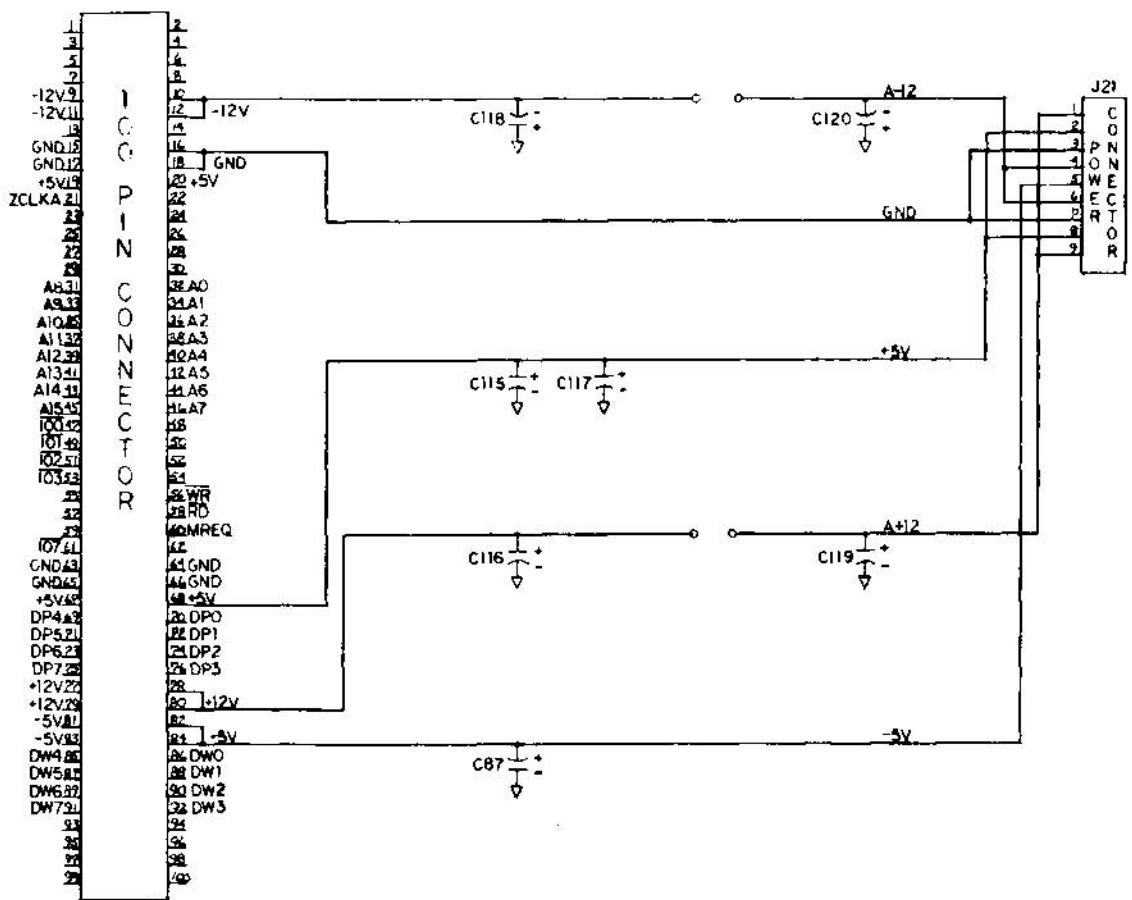

LEFT

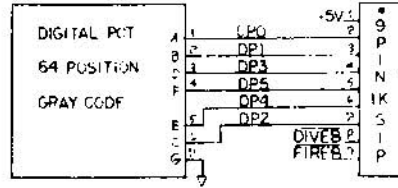

RIGHT

