

CB Schematic (035435-02 E)

the dual functions of reg- to the game PCB and am- PCB.

ltage regulator Q1, power r transistor Q2. The regula- c power input to the game through high-impedance in- e inputs are directly from o the game PCB. Therefore, ge on the game PCB. This ue to IR loss in the wire nd the game PCB. Variable 5 VDC on the game PCB. input of the game PCB will

+ 5 V and GND test points

on the Regulator/Audio II the voltmeter.

n + 5 V REG and GND on Voltage reading must not greater, try cleaning edge me PCB and the Regula-

tors doesn't decrease volt- is lead of voltmeter to GND o II PCB and plus lead to 3. Note the voltage. f voltmeter to + 5 REG test PCB and plus lead to + 5 V m this you can see which the voltage. Troubleshoot or harness connector.

Independent audio ampli- TDA2002AV amplifier with

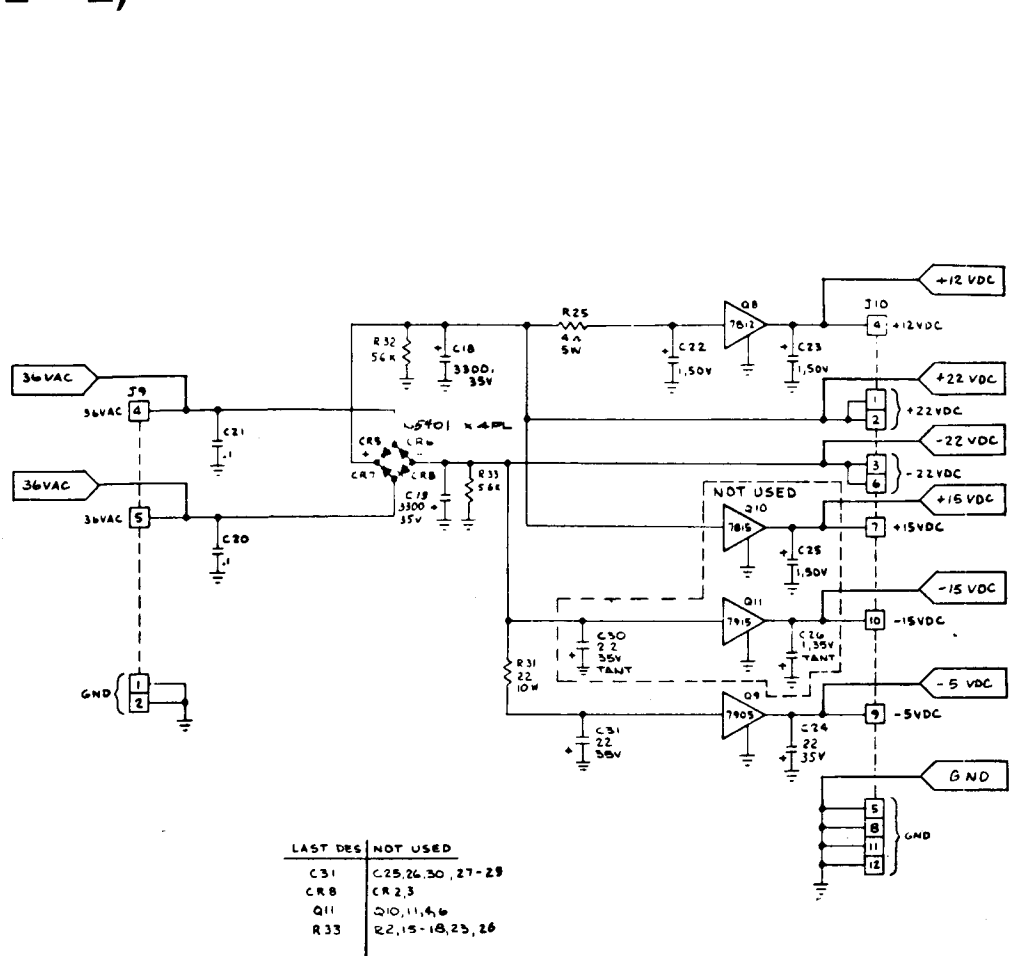

LAST DEC	NOT USED
C31	C25, 24, 30, 27, 28
C32	C2, 3
Q11	2SD114, 4
R33	R2, 15, 18, 23, 24

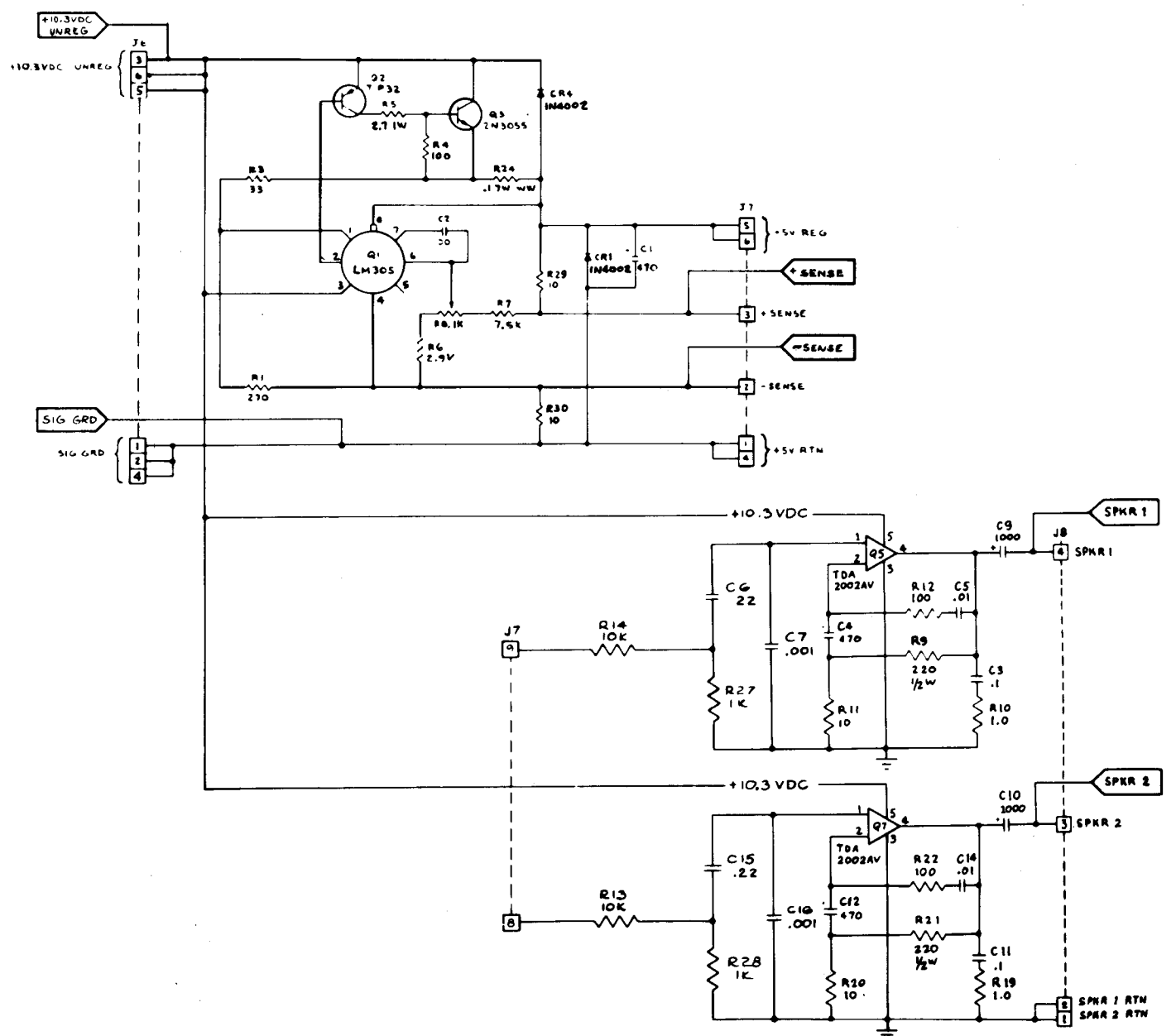

Denotes a test point

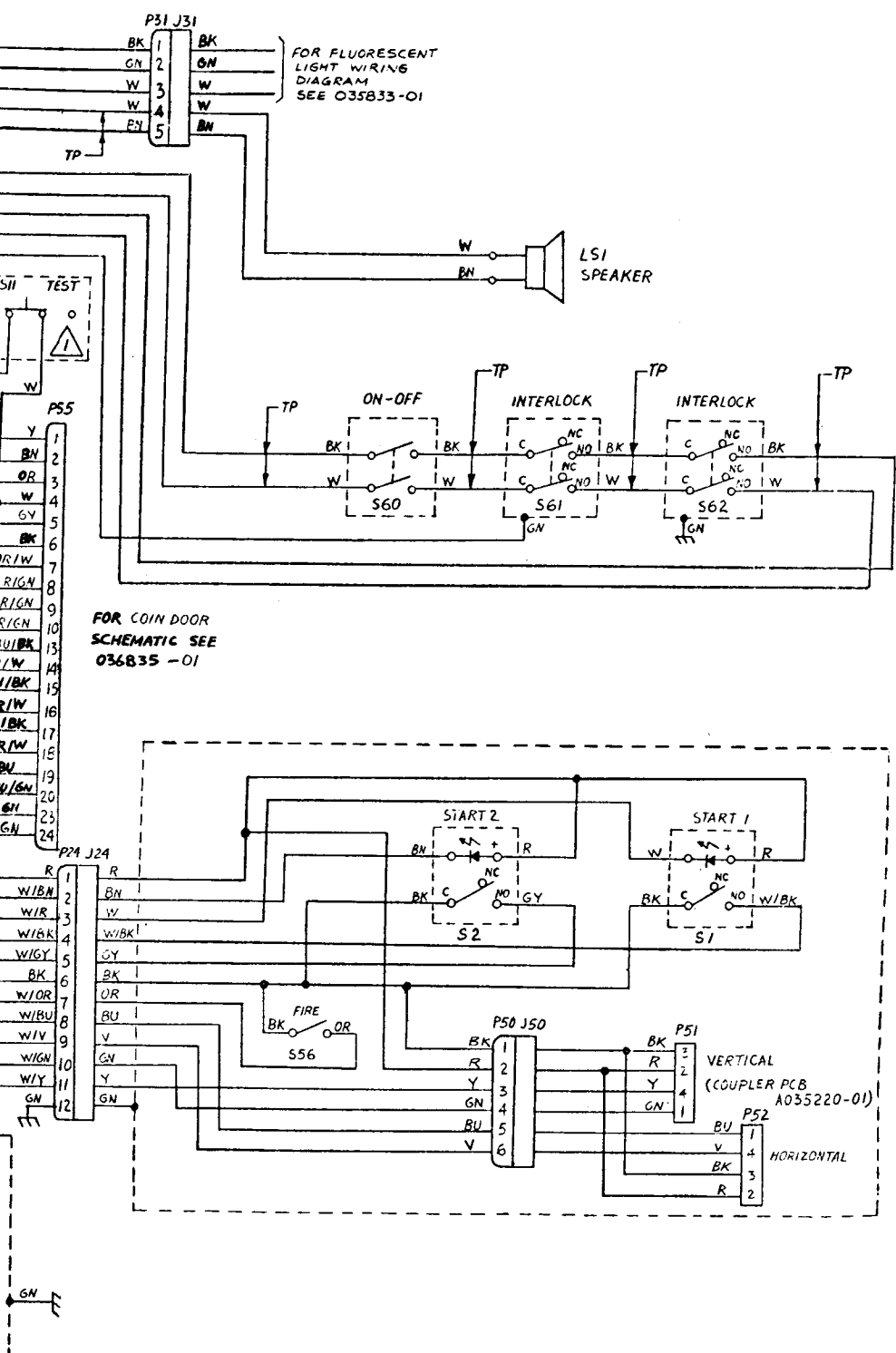

American-Made Coin Door Schematic (036835-01 B)

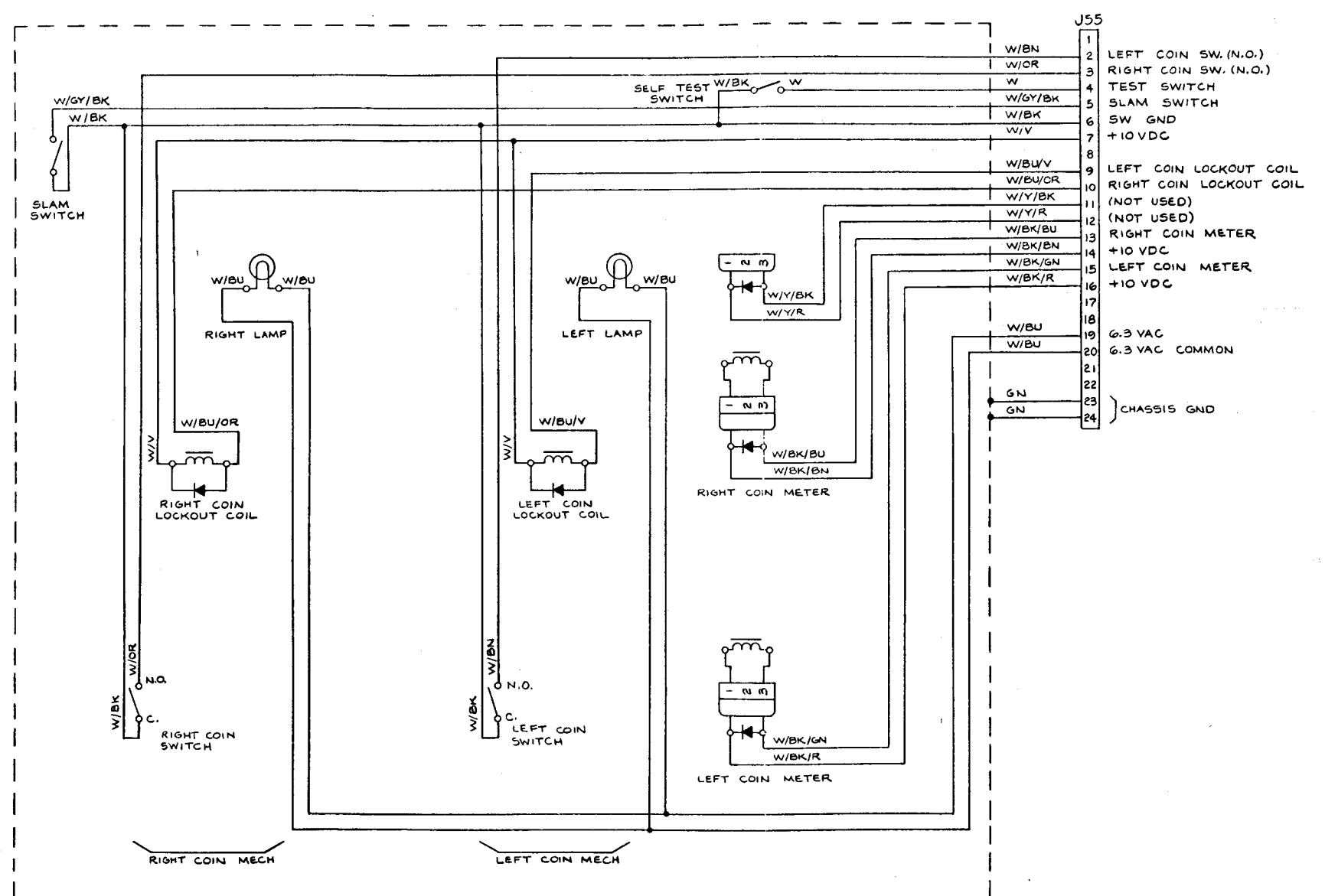

British-Made Coin Door Schematic (037050-01 A)

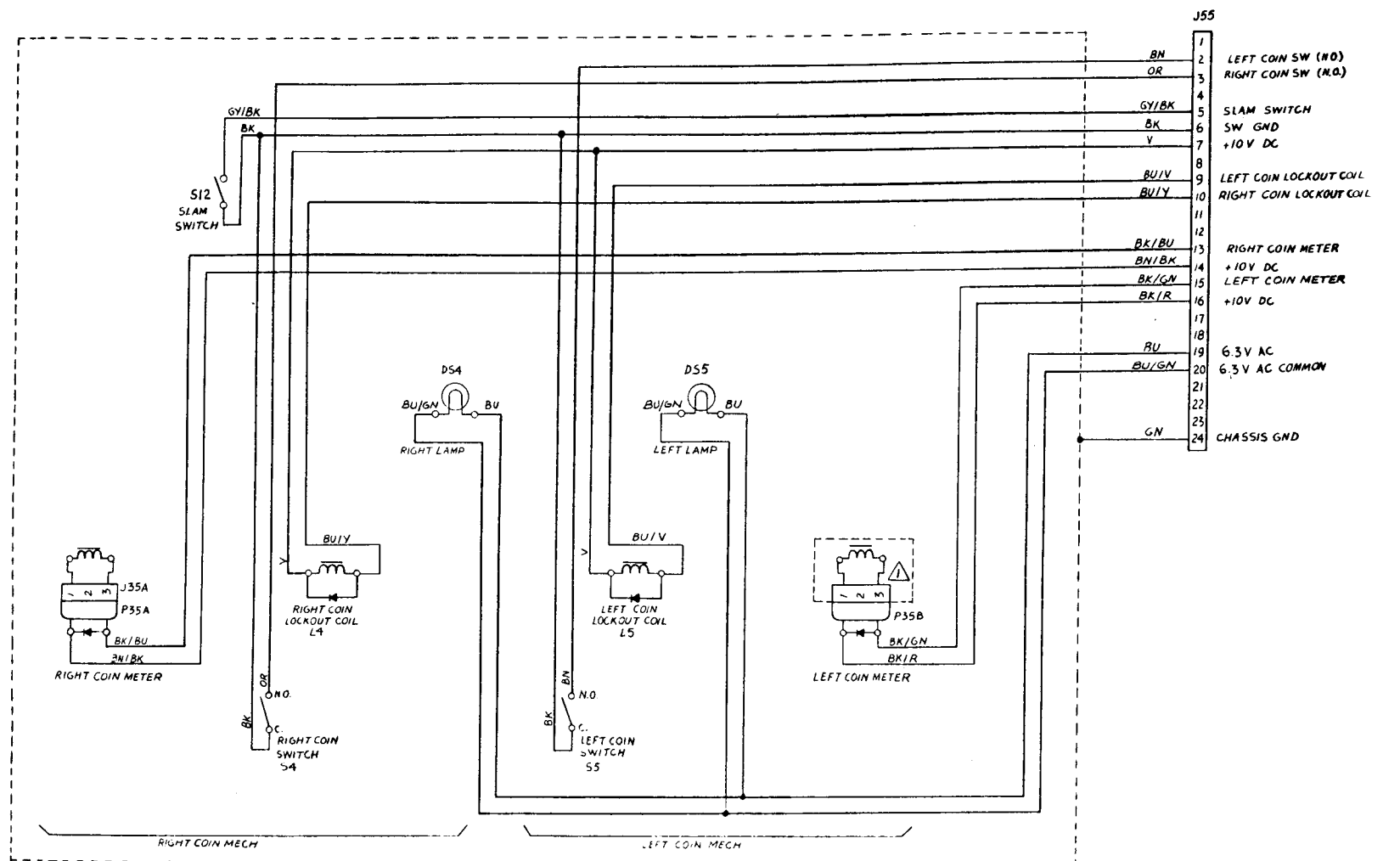

Synchronizer

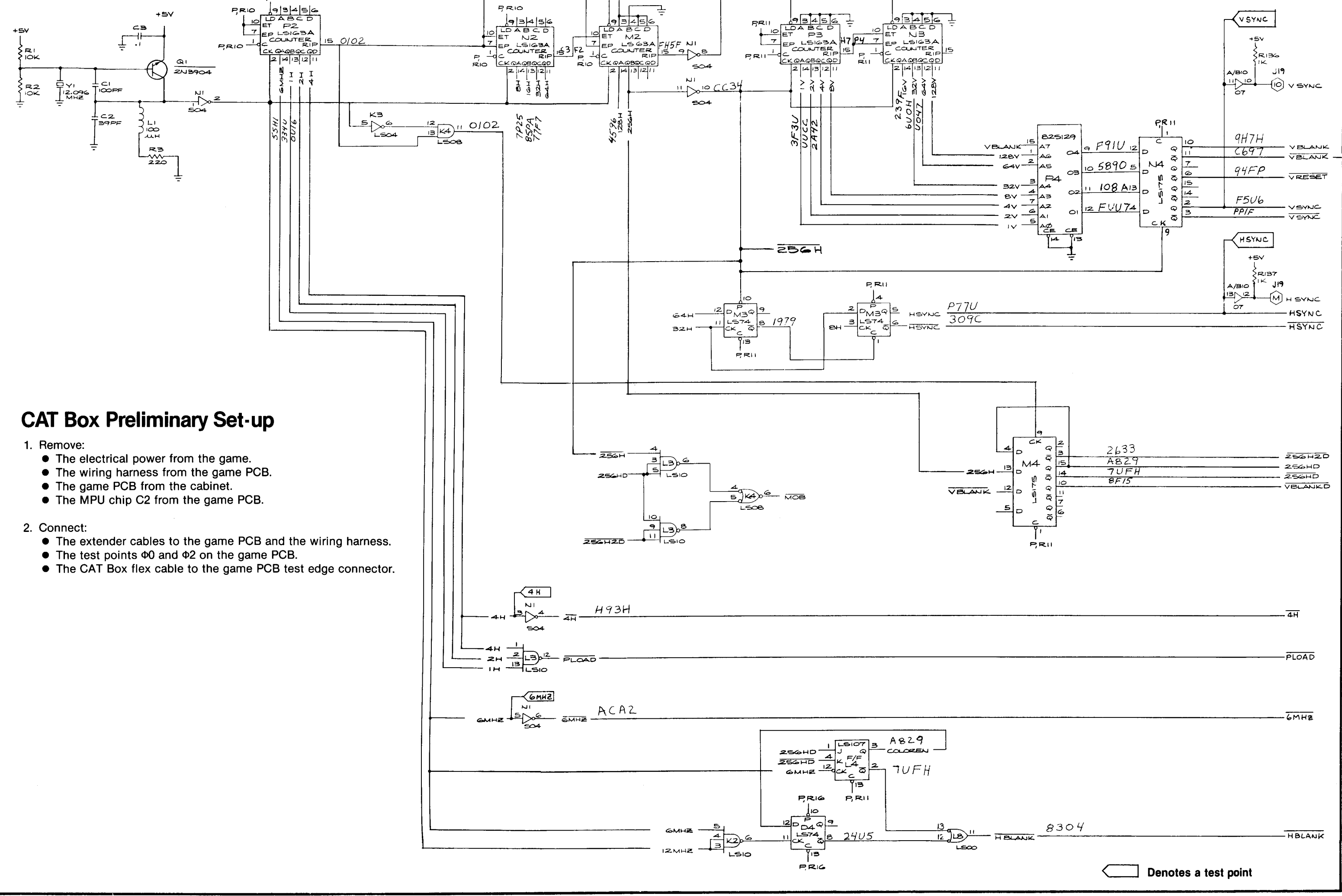

CAT Box Preliminary Set-up

- Remove:
 - The electrical power from the game.
 - The wiring harness from the game PCB.
 - The game PCB from the cabinet.
 - The MPU chip C2 from the game PCB.
- Connect:
 - The extender cables to the game PCB and the wiring harness.
 - The test points $\Phi 0$ and $\Phi 2$ on the game PCB.
 - The CAT Box flex cable to the game PCB test edge connector.

Diagnostic Tests

Instruction	Use of Test																
1. Hold the slam switch closed, while setting the self-test switch to the on position.	The monitor displays the color hue adjustment pattern of 16 rectangles, as follows. Do not attempt any color hue or brightness adjustments unless you are a qualified color TV technician!																
	<table border="0"> <tr> <td>Pale Yellow-Green</td> <td>Orange</td> <td>White</td> <td>Deep Yellow</td> </tr> <tr> <td>Light Green</td> <td>Dark Green</td> <td>Light Blue</td> <td>Lime Green</td> </tr> <tr> <td>Deep Rose</td> <td>Red</td> <td>Purple</td> <td>Red</td> </tr> <tr> <td>Navy Blue</td> <td>Black</td> <td>Royal Blue</td> <td>Black</td> </tr> </table>	Pale Yellow-Green	Orange	White	Deep Yellow	Light Green	Dark Green	Light Blue	Lime Green	Deep Rose	Red	Purple	Red	Navy Blue	Black	Royal Blue	Black
Pale Yellow-Green	Orange	White	Deep Yellow														
Light Green	Dark Green	Light Blue	Lime Green														
Deep Rose	Red	Purple	Red														
Navy Blue	Black	Royal Blue	Black														
2. Activate any of the coin switches on the coin door.	A convergence pattern appears with a grid of white dots on a black screen. Do not attempt any convergence adjustments unless you are a qualified color TV technician!																
3. Set self-test switch to the off position.	Check attract-mode display and readjust brightness if necessary.																

NOTICE TO ALL PERSONS RECEIVING THIS DRAWING
 CONFIDENTIAL: Reproduction forbidden without the
 specific written permission of Atari, Inc., Sunnyvale, CA.
 This drawing is only conditionally issued, and neither
 receipt nor possession thereof confers or transfers any
 right in, or license to use, the subject matter of the drawing
 or any design or technical information shown thereon,
 nor any right to reproduce this drawing or any part
 thereof. Except for manufacture by vendors of Atari, Inc.,
 and for manufacture under the corporation's written
 license, no right to reproduce this drawing is granted or
 the subject matter thereof unless by written agreement
 with or written permission from the corporation.

Sheet 1, Side B
Centipede™
 Synchronizer
 CAT Box Preliminary Set-Up
 Power Input
 Microprocessor
 Address Decoder
 RAM
 ROM
 Memory Map
 Section of 037241-01 G

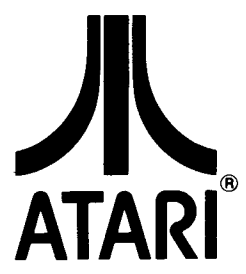

© 1981 Atari, Inc.

Power Input

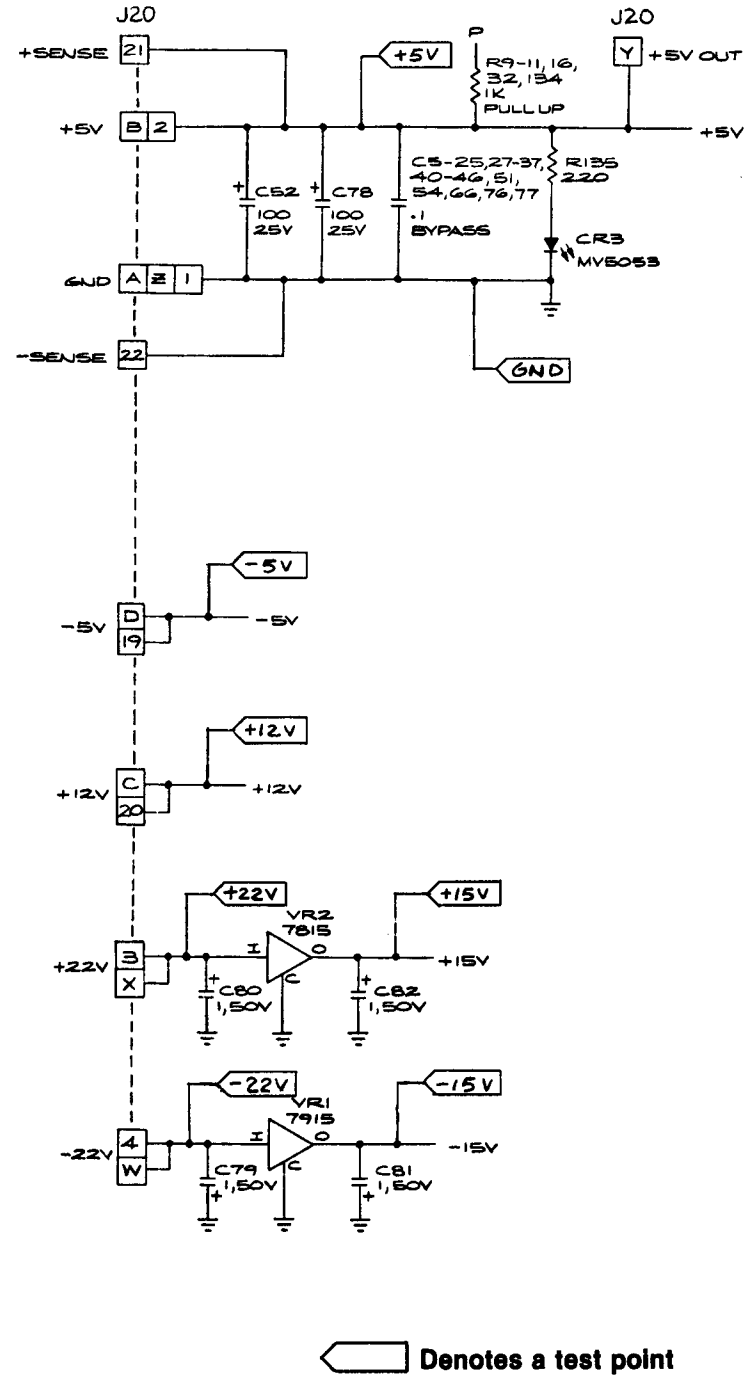

Testing the RA

- Perform the CAT Box
- Set the CAT Box with:
 - Press TESTER RE
 - DBUS SOURCE TO
 - BYTES to 1024
 - R/W MODE to (OF
 - R/W to WRITE
 - Key in 0000
 - Set R/W MODE to
 - R/W to READ
 - Set R/W MODE to
- If the CAT Box reads a PARE ERROR LED is shown the failing address. Press PLAY switch is enable
- If the COMPARE ERR repeat the test with the ensures that the data COMPARE ERROR LED is good.

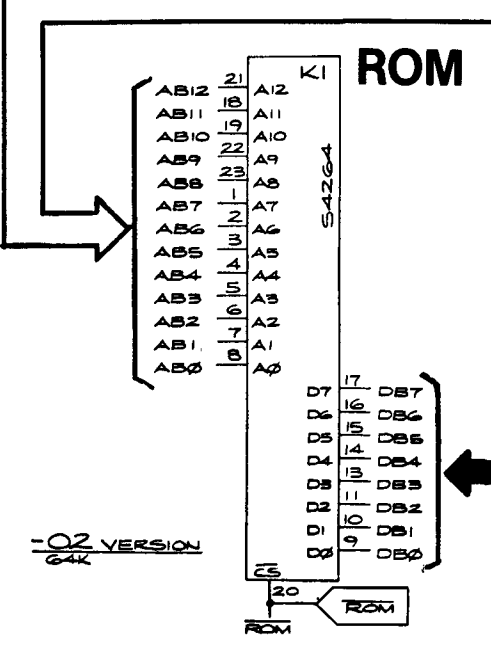

TEST CONNECTOR-FOR ATARI CAT BOX

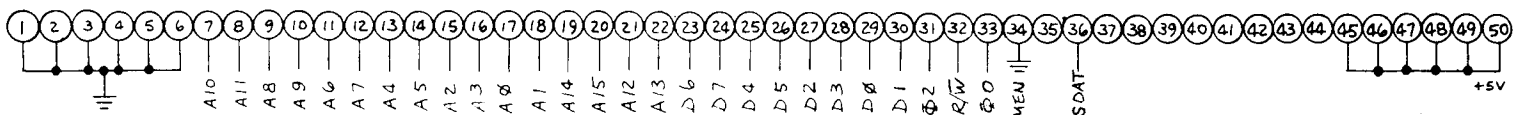

To/From Sheet 2, Side A
Sheet 2, Side B

Microprocessor

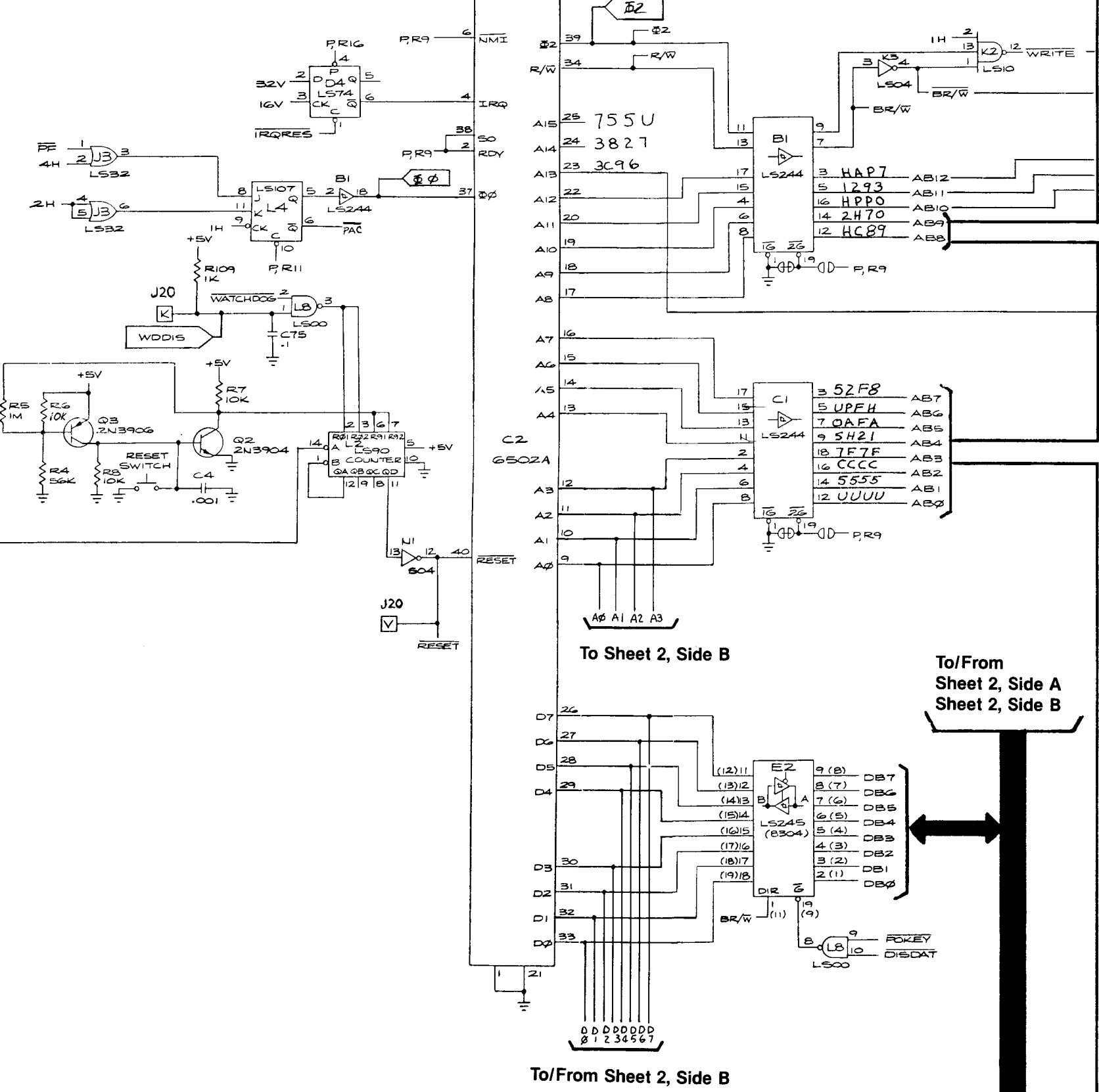

Denotes a test point

Address Decoder

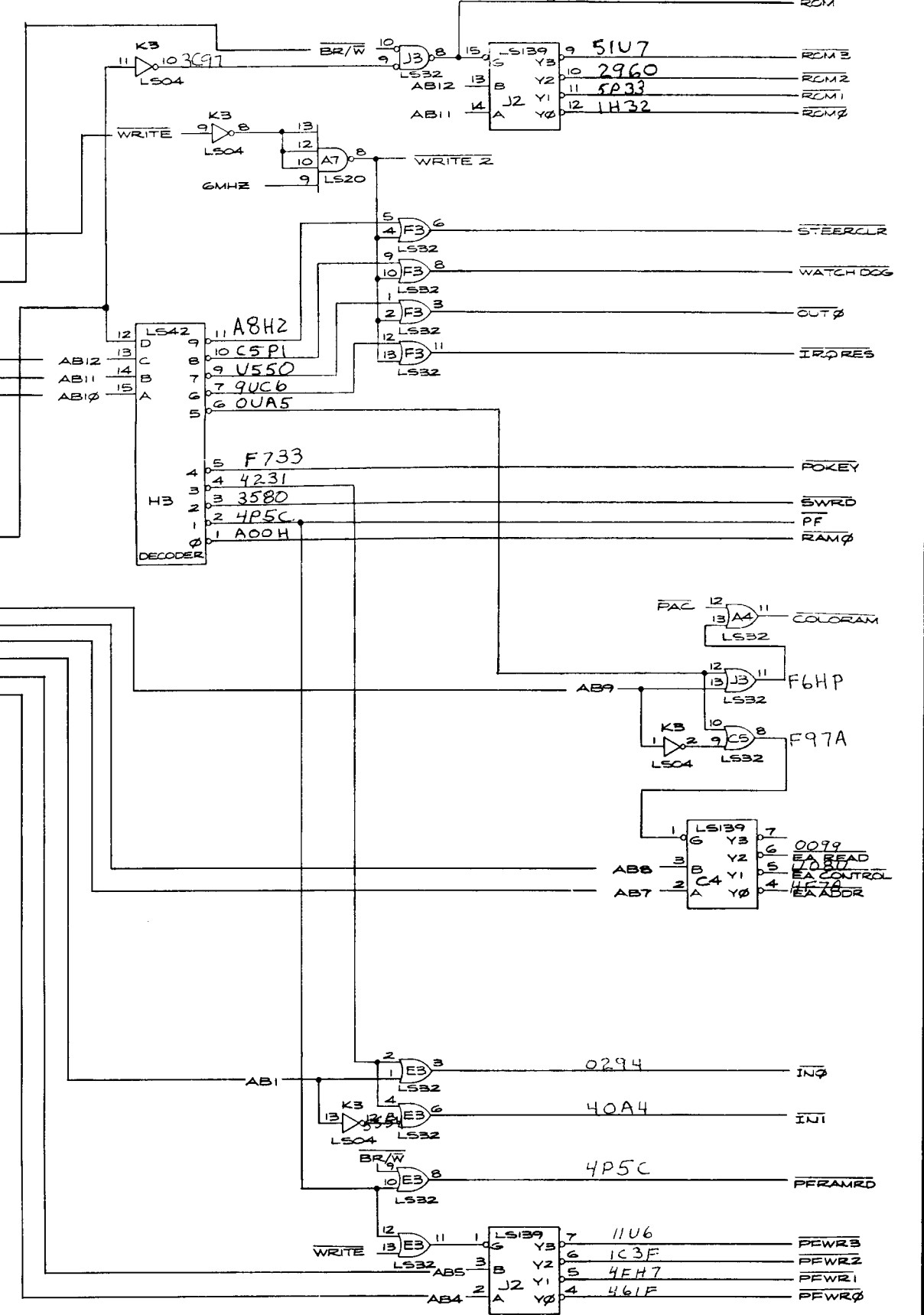

RAM

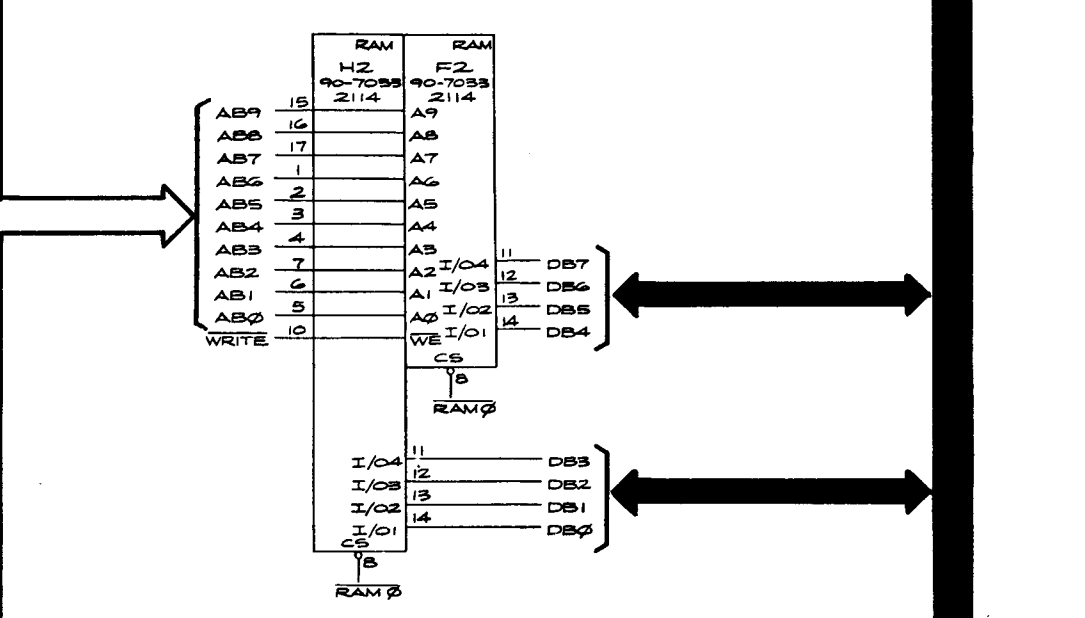

Memory Map

MEMORY MAP										
HEXA-DECIMAL ADDRESS	R/W	D7	D6	D5	D4	D3	D2	D1	D0	FUNCTION
0000-03FF		D	D	D	D	D	D	D	D	RAM
0400-07BF		D	D	D	D	D	D	D	D	Playfield RAM
07C0-07CF		D	D	D	D	D	D	D	D	Motion Object Picture
07D0-07DF		D	D	D	D	D	D	D	D	Motion Object Vert.
07E0-07EF		D	D	D	D	D	D	D	D	Motion Object Horiz.
07F0-07FF		D	D	D	D	D	D	D	D	Motion Object Color
0800	R	D	D	D	D	D	D	D	D	Option Switch 1 (0 = On)
0801	R	D	D	D	D	D	D	D	D	Option Switch 2 (0 = On)
0C00	R	D					D	D	D	Horizontal Mini-Trak Ball™ Inputs
	R		D							VBLANK (1 = VBlank)
	R			D						Self-Test (0 = On)
	R				D					Cocktail Cabinet (1 = Cocktail)
0C01	R	D	D	D						R, C, L Coin Switches (0 = On)
	R									SLAM (0 = On)
	R						D			Player 2 Fire Switch (0 = On)
	R							D		Player 1 Fire Switch (0 = On)
	R								D	Player 2 Start Switch (0 = On)
	R								D	Player 1 Start Switch (0 = On)
0C02	R	D					D	D	D	Vertical Mini-Trak Ball™ Inputs
0C03	R	D	D	D	D			D	D	Player 1 Joystick (R, L, Down, Up)
	R								D	Player 2 Joystick (0 = On)
1000-100F	R/W	D	D	D	D	D	D	D	D	Custom Audio Chip
1404	W						D	D	D	Playfield Color RAM
140C	W						D	D	D	Motion Object Color RAM
1600	W	D	D	D	D	D	D	D	D	EA ROM Address & Data Latch
1680	W						D	D	D	EA ROM Control Latch
1700	R	D	D	D	D	D	D	D	D	EA ROM Read Data
1800	W									IRQ Acknowledge
1C00	W	D								Left Coin Counter (1 = On)
1C01	W	D								Center Coin Counter (1 = On)
1C02	W	D								Right Coin Counter (1 = On)
1C03	W	D								Player 1 Start LED (0 = On)
1C04	W	D								Player 2 Start LED (0 = On)
1C07	W	D								Trak Ball™ Flip Control (0 = Player 1)
2000	W									WATCHDOG
2400	W									Clear Mini-Trak Ball™ Counters
2000-3FFF	R									Program ROM

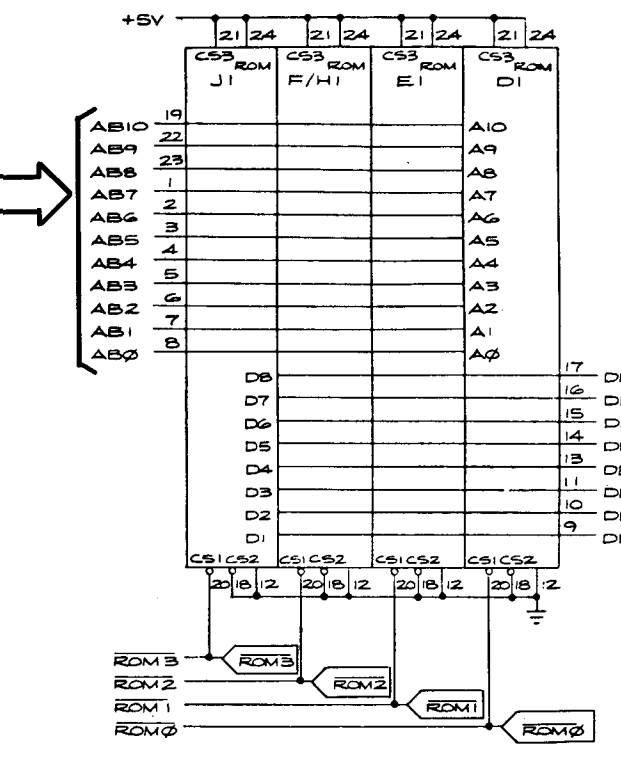

	-200 Version				-300 Version				
	D1	E1	F/H1	J1	D1	E1	F/H1	J1	
START	Pin 20	Pin 20	Pin 20	Pin 20	Pin 20	Pin 20	Pin 20	Pin 20	
STOP	Pin 20	Pin 20	Pin 20	Pin 20	Pin 20	Pin 20	Pin 20	Pin 20	
CLOCK	φ 2	φ 2	φ 2	φ 2	Pin 20	Pin 20	Pin 20	Pin 20	
Pin 9	5AF2	13PH	CU62	476H	Pin 9	8H07	2956	77C1	75CU
Pin 10	3276	C4P5	9553	2A2C	Pin 10	7916	18F6	04CC	3FFA
Pin 11	48UH	11F3	7756	2337	Pin 11	7052	F829	11F0	F717
Pin 13	P316	098P	A7CF	FP07	Pin 13	H3FH	6200	6UC2	H5U0
Pin 14	PF7A	5H24	6081	A9AF	Pin 14	H6F1	47C0	1300	959U
Pin 15	H973	0548	5HAC	12HA	Pin 15	1322	F341	6572	5050
Pin 16	3F34	33P7	6U43	2367	Pin 16	U577	67FP	U047	C439
Pin 17	U638	80AA	F83H	8P82	Pin 17	F189	8UF5	9U68	HF82

-01 VERSION 16M

From MPU
Address Bus
Sheet 1, Side B

From Sync
Generator
Sheet 1, Side B

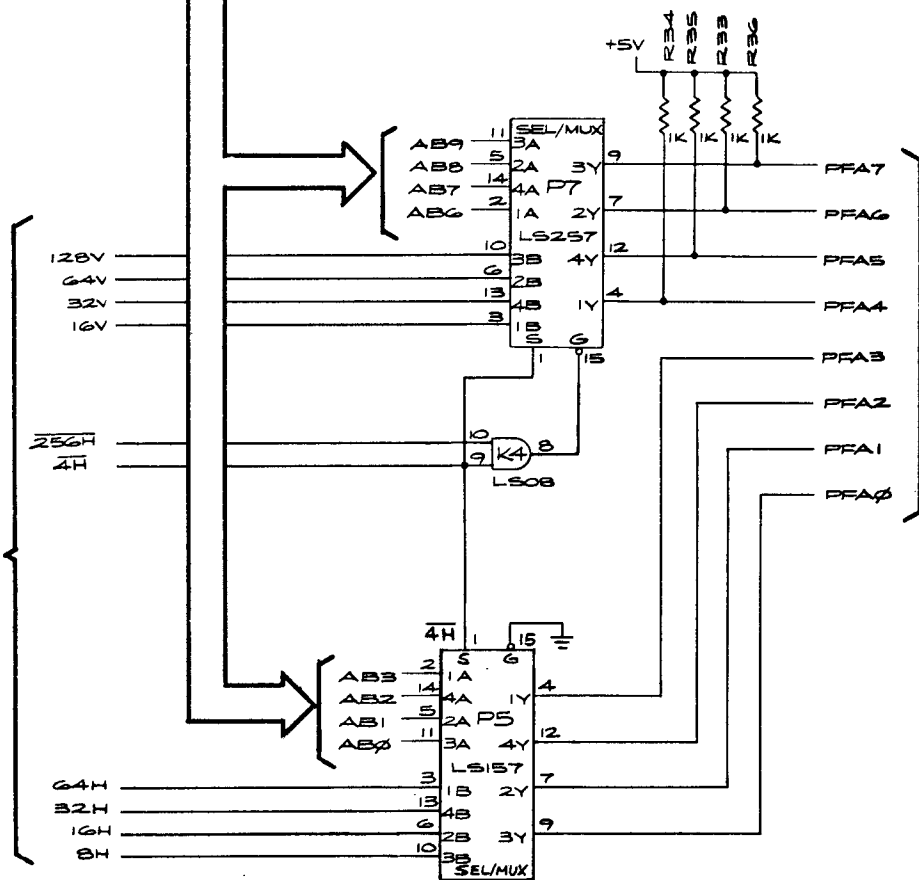

Playfield Address Selector

The Playfield Address Selector controls the access to the playfield memory. It allows either the game MPU or the sync generator to scan the playfield memory. The Playfield Address Selector consists of multiplexers P5, and P7 and gate K4.

When 4H on pin 1 of P5 and P7 is low and pin 15 on P7 is low, the Playfield Address Selector receives 8H, 16H, 32H, and 64H on P5 and 16V, 32V, 64V, and 128V on P7 from the sync generator. These signals enable the sync generator circuits to access the playfield memory.

When 4H goes high the game MPU addresses the playfield memory (via AB0-AB9) for the positioning of the graphics. During horizontal blanking (pin 15 of P7 is high) the outputs of P7 (PFA4-PFA7) are held high enabling the motion object circuitry to access the playfield memory for the motion objects to be displayed.

NOTICE TO ALL PERSONS RECEIVING THIS DRAWING
CONFIDENTIAL: Reproduction forbidden without the specific written permission of Atari, Inc., Sunnyvale, CA. This drawing is only conditionally issued, and neither receipt nor possession thereof confers or transfers any right in, or license to use, the subject matter of the drawing or any design or technical information shown thereon, nor any right to reproduce this drawing or any part thereof. Except for manufacture by vendors of Atari, Inc., and for manufacture under the corporation's written license, no right to reproduce this drawing is granted or the subject matter thereof unless by written agreement with or written permission from the corporation.

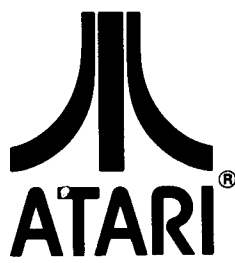

Sheet 2, Side A

Centipede™

Playfield Address Selector
Playfield Memory
Playfield Multiplexer
Picture Data ROM Circuitry
Motion Object Circuitry (Vertical)
Motion Object Circuitry (Horizontal)

Section of 037241-01 H

© 1981 Atari, Inc.

Centipede Playfield RAM

Testing the Playfield RAM

1. Perform the CAT Box preliminary set-up.
2. Set the CAT Box switches as follows:
 - a. Press TESTER RESET
 - b. DBUS SOURCE TO ADDR
 - c. BYTES to 1024
 - d. R/W MODE to (OFF)
 - e. R/W to WRITE
 - f. Key in 0400
 - g. Set R/W MODE to PULSE, then to OFF.
 - h. R/W to READ
 - i. Set R/W MODE to PULSE, then to OFF.
3. If the CAT Box reads an address that doesn't compare, the COMPARE ERROR LED lights, the ADDRESS/SIGNATURE display shows the failing address location, and the ERROR DATA DISPLAY switch is enabled.
4. If the COMPARE ERROR LED does not light, rekey 0400 and repeat the test with the DBUS SOURCE switch set to ADDR. This ensures that the data bits at address 0400 will go high. If the COMPARE ERROR LED does not light after this step, the Playfield RAM is good.

To/From MPU
Data Bus
Sheet 1, Side B

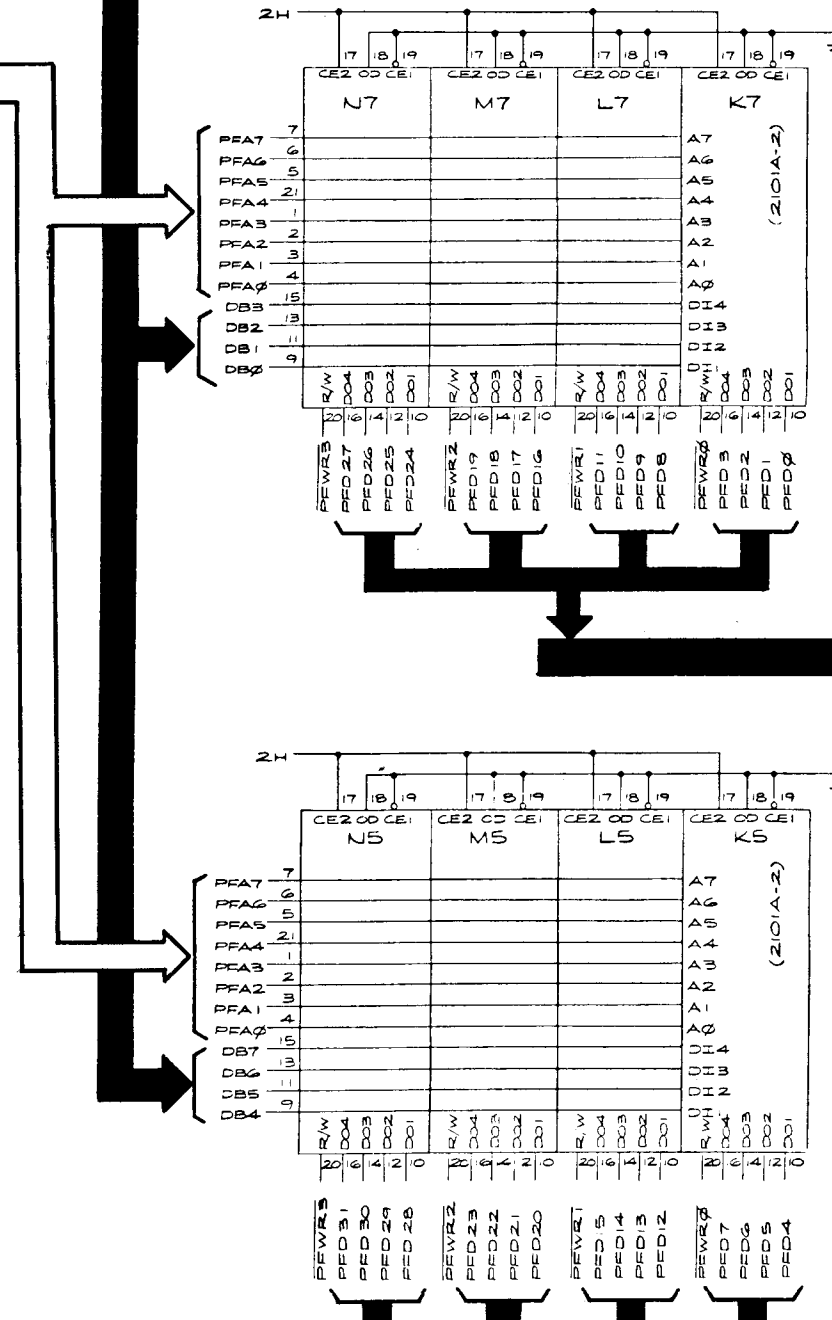

Motion Object Circuitry (Vertical)

The Motion Object Circuitry (vertical) receives playfield data and vertical sync generator circuitry to generate the vertical component of the motion. The output is gated by A7 when a motion object is on one of the sixteen lines latched by E6 to AND gate B7. A low on B7 pin 8 indicates the presence of one of the vertical lines during non-active video time. This signal (MATCH) is used in the picture data circuitry.

When 256H on pin 1 of D7 goes high, 1V, 2V, 4V and PIC0 are selected. When the latched output of E6 is selected. The output of D7 is EXCLUSIVE OR sent to the picture data selector circuitry as motion graphic address (MGA). The input to EXCLUSIVE OR gate E7 is PIC7 from the playfield code multiplexer when high causes the output of E7 to be complimented. For example, if MGA0-MGA3 to go high. This causes the motion object video to bottom.

From Sync
Generator
Sheet 1, Side B

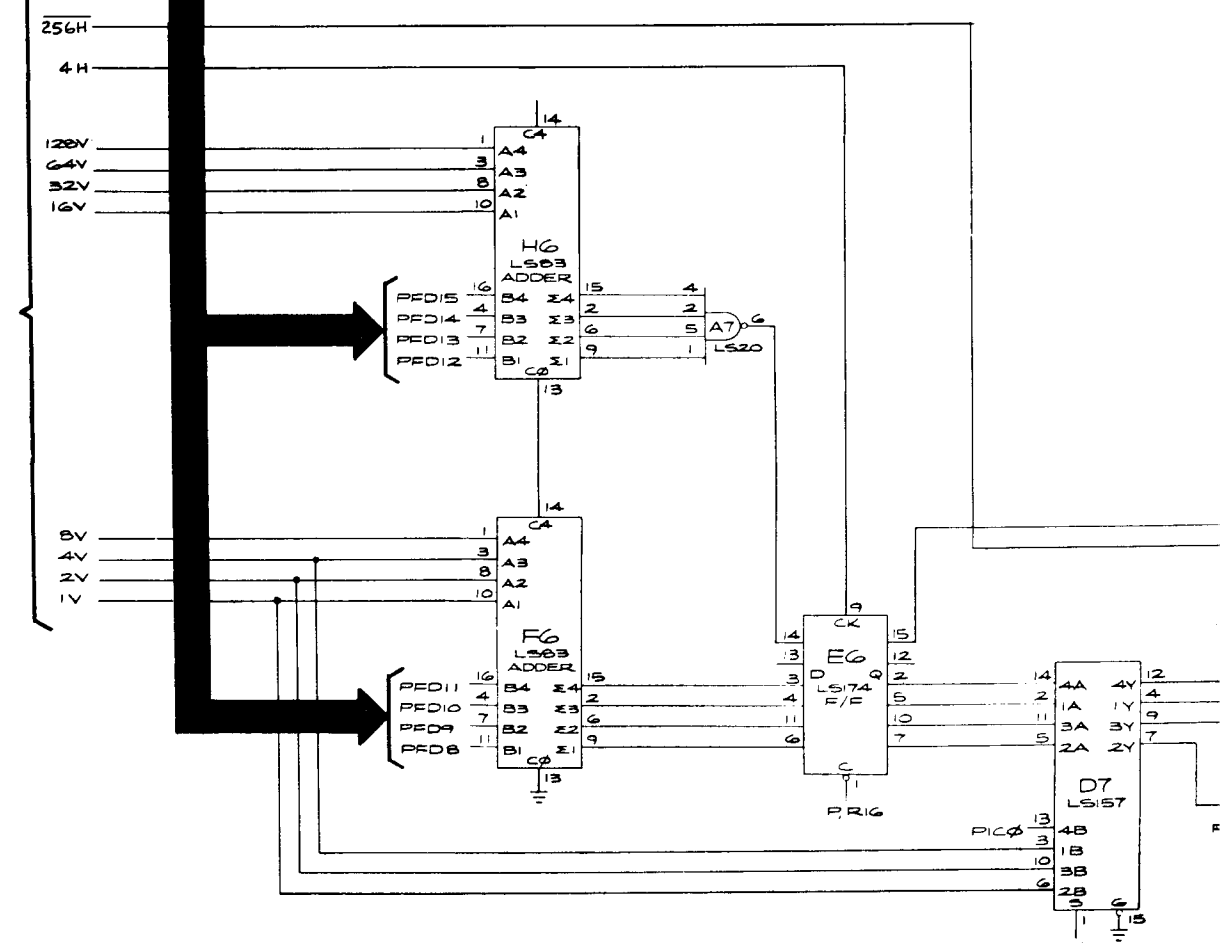

The Playfield (PFD0-PFD31) are played on the motion object circuitry. The output consists of selected outputs.

When 256H is selected output as select inputs playfield data is selected. When 256H is low, the input These signals to M6, and N6 for

The playfield data is selected output as select inputs playfield data is selected. When 256H is low, the input These signals to M6, and N6 for

Joystick Circuitry

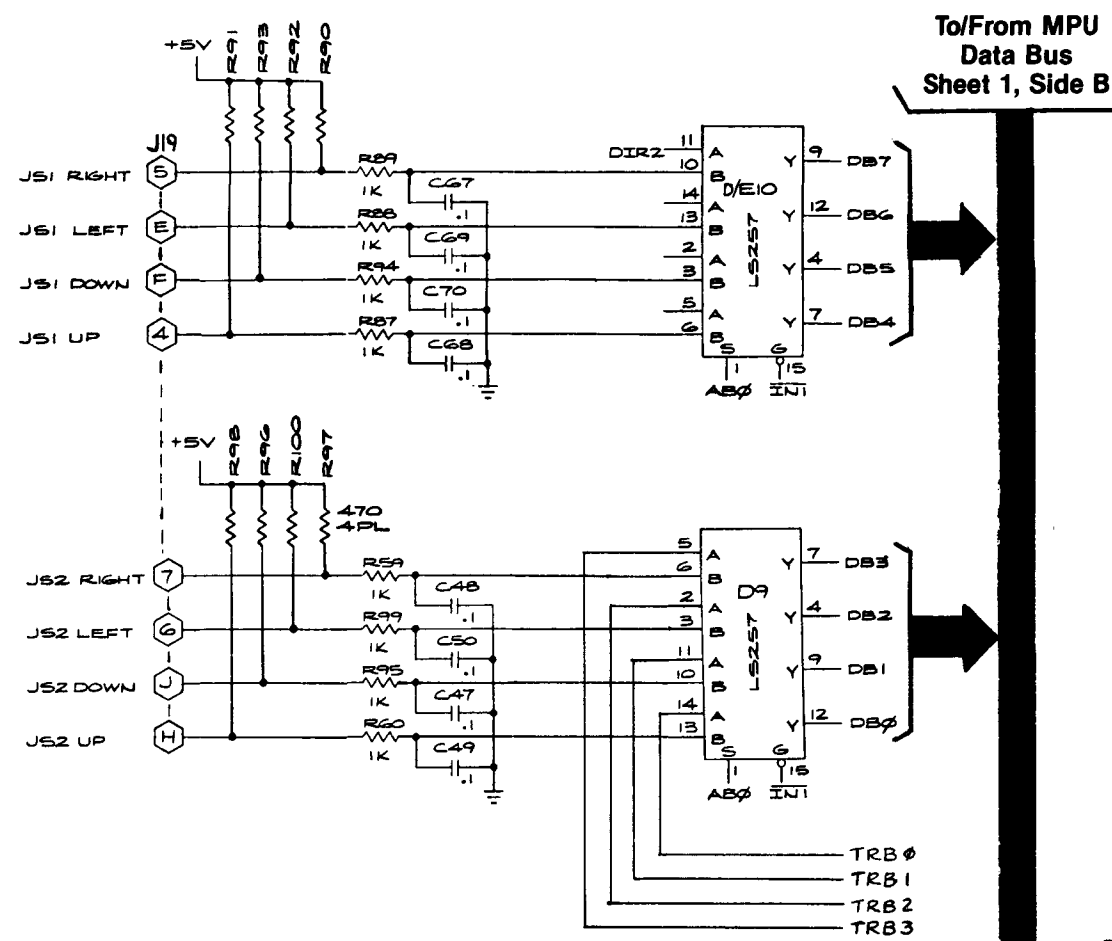

Player Input Circuitry

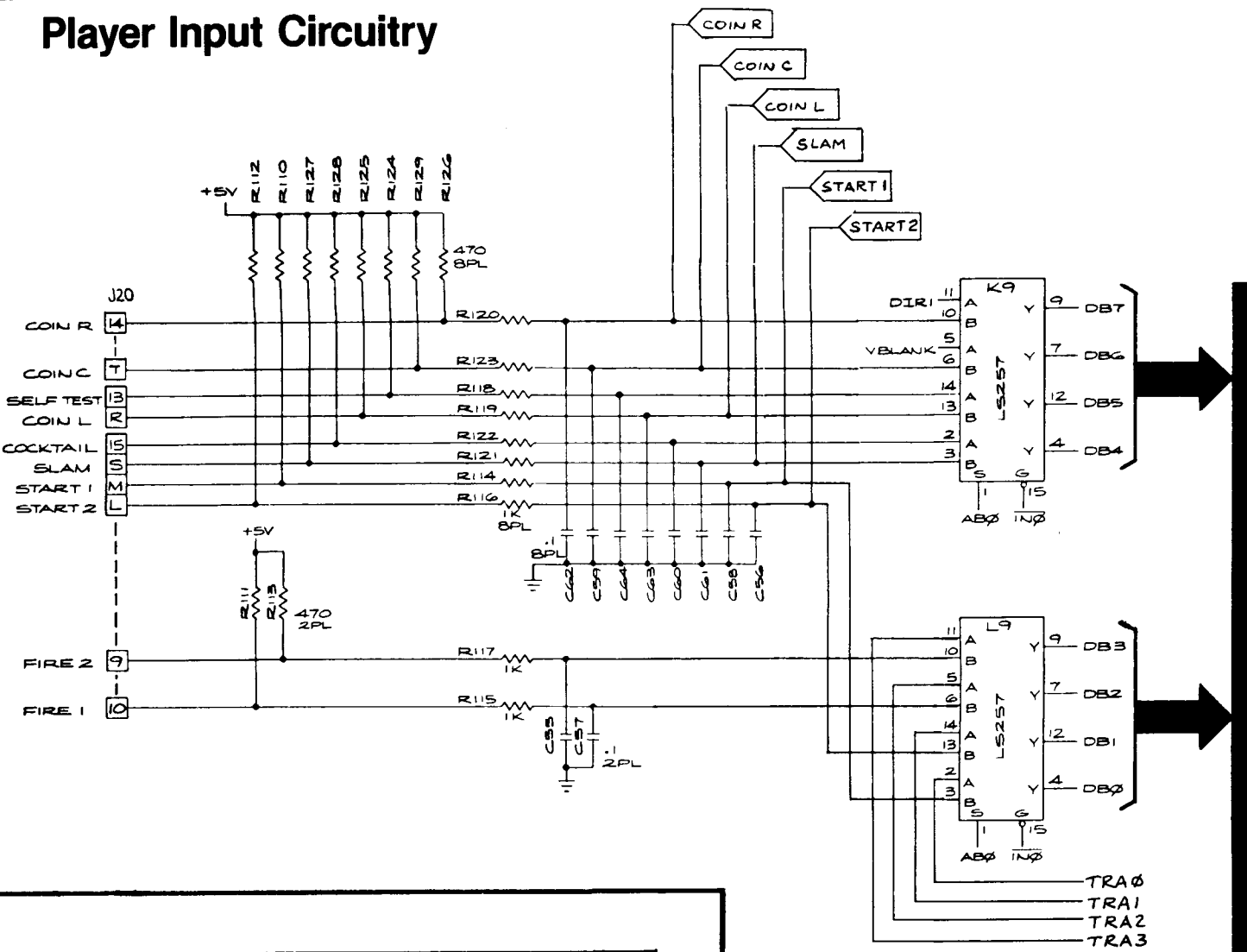

Option Input Circuitry

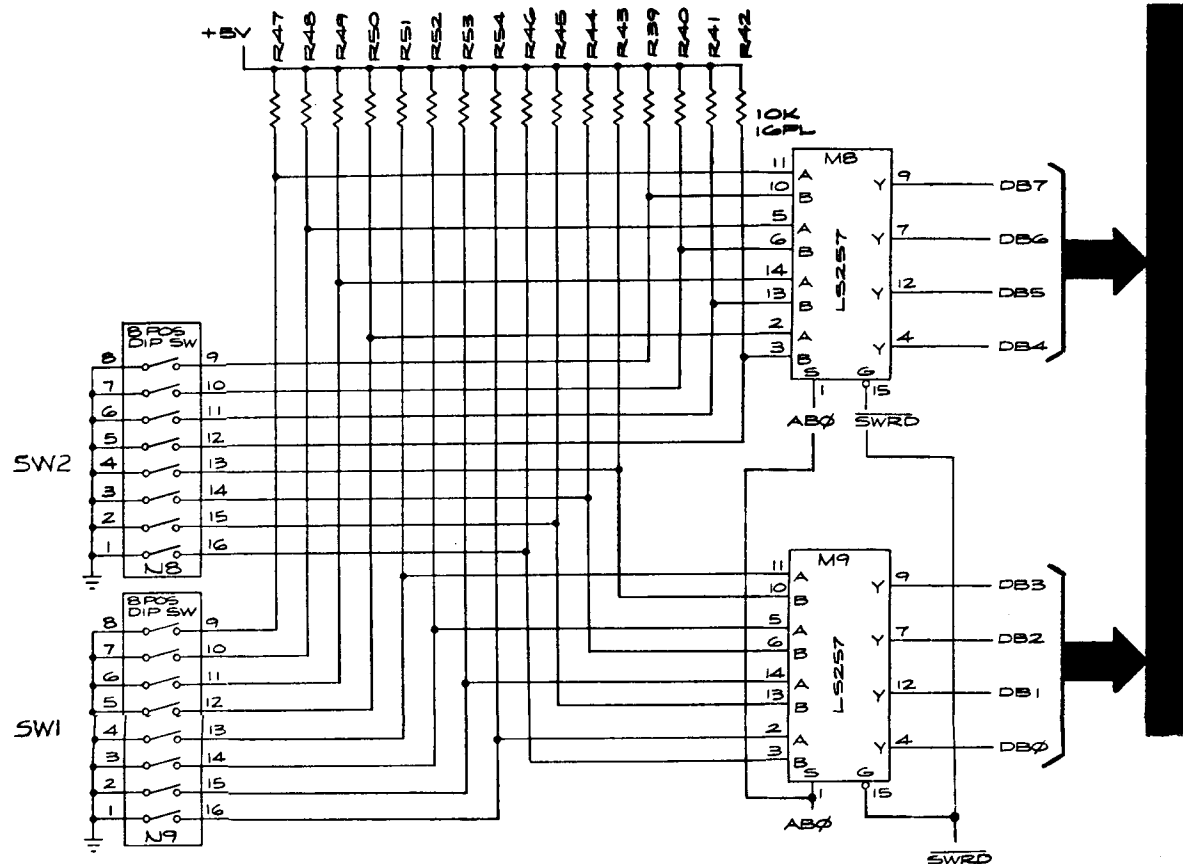

Testing the Option Switches

1. Perform the CAT Box preliminary set-up.
2. Set the CAT Box switches as follows:
 - a. DBUS SOURCE to DATA
 - b. BYTES to 1
 - c. R/W to READ
 - d. Key in address 0800 (N9) or 0801 (N8)
 - e. R/W MODE to STATIC
3. Activate the switch while monitoring the DATA DISPLAY. The DATA DISPLAY will change if the switch is operating properly.

Coin Counter Output Circuitry

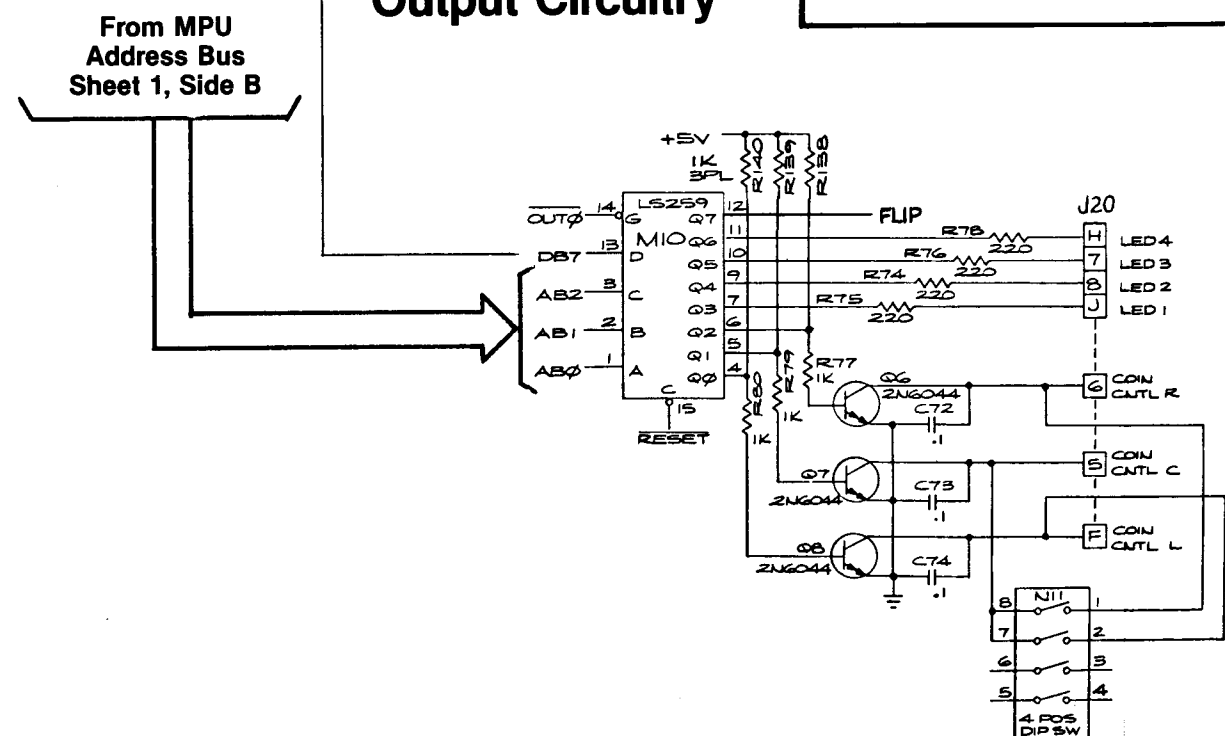

Coin Counter Output Circuit

This circuit consists of coin counter drivers Q6, Q7, and Q8 and data latch M10. The circuit is addressed by the MPU on AB0-AB2 and written by the MPU on data line DB7. When the input to a driver is clocked high, its collector goes low grounding the return of the coin counter in the coin door.

NOTICE TO ALL PERSONS RECEIVING THIS DRAWING
 CONFIDENTIAL: Reproduction forbidden without the
 specific written permission of Atari, Inc., Sunnyvale, CA.
 This drawing is only conditionally issued, and neither
 receipt nor possession thereof confers or transfers any
 right in, or license to use, the subject matter of the drawing
 or any design or technical information shown thereon,
 nor any right to reproduce this drawing or any part
 thereof. Except for manufacture by vendors of Atari, Inc.,
 and for manufacture under the corporation's written
 license, no right to reproduce this drawing is granted or
 the subject matter thereof unless by written agreement
 with or written permission from the corporation.



Sheet 2, Side B

Centipede™

- Joystick Circuitry
- Mini-Trak Ball™ Circuitry
- Player Input Circuitry
- Video Output Circuitry
- Audio Output Circuitry
- Coin Counter Output Circuitry
- Option Input Circuitry
- High Score Memory Circuitry

Section of 037241-01 H

© 1981 Atari, Inc.

Mini-Trak Ball™ Circuitry

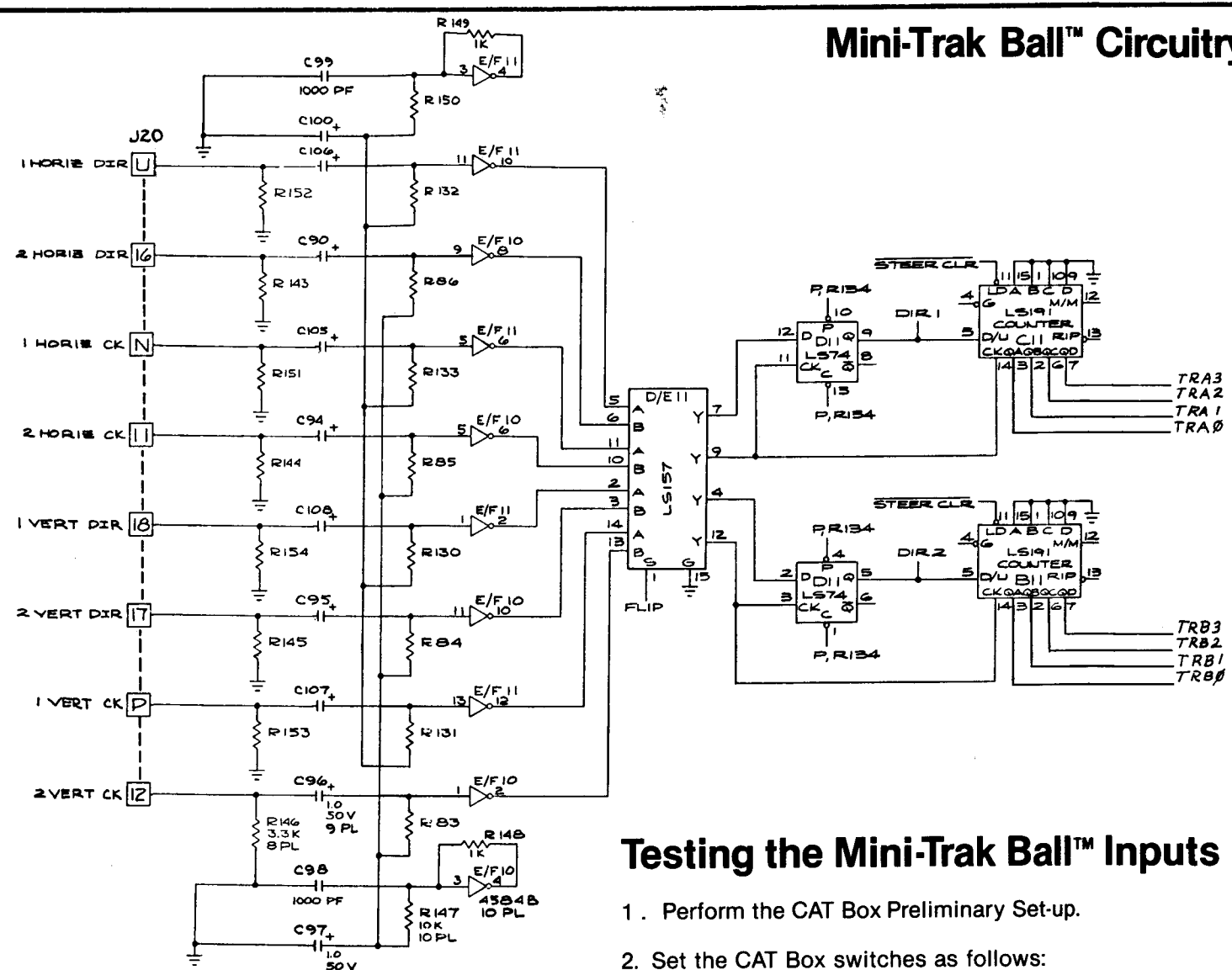

Testing the Mini-Trak Ball™ Inputs

1. Perform the CAT Box Preliminary Set-up.
2. Set the CAT Box switches as follows:
 - a. DBUS SOURCE to DATA
 - b. BYTES to 1
 - c. R/W to READ
 - d. Key in address 0C00 (vertical) or 0C02 (horizontal)
 - e. R/W MODE to PULSE
3. Spin the Mini-Trak Ball™ while monitoring the DATA DISPLAY. The DATA DISPLAY will change if the Mini-Trak Ball input is operating properly.

Testing the Player Inputs

- Perform the CAT Box Preliminary Set-up.
- Set the CAT Box switches as follows:
 - DBUS SOURCE to DATA
 - BYTES to 1
 - R/W to READ
 - Key in address 0C00 (self-test switch only) or 0C01 (all others).
 - R/W MODE to STATIC
- Activate the following player input switches, one at a time, while monitoring the DATA DISPLAY:
 - Coin Right
 - Coin Left
 - SLAM
 - FIRE
 - START 1
 - START 2
- The DATA DISPLAY will change if the switches are operating properly.

Testing the Audio Outputs

- Perform the CAT Box preliminary set-up.
- Set the CAT Box switches as follows:
 - DBUS SOURCE to DATA
 - BYTES to 1
 - R/W to WRITE
 - Key in address or press ADDRESS INCR
 - Press DATA SET
 - Key in data
 - Set R/W MODE to PULSE, then to OFF.
 - For each address, repeat sequence starting at Step d.

ADDRESS	DATA	RESULTS
100F	00	
100F	03	
1000	55	
1001	AF	Pure tone is heard from channel 1 output.
1001	00	Channel 1 output is turned off.
1002	55	
1003	AF	Pure tone is heard from channel 2 output.
1003	00	Channel 2 output is turned off.
1004	55	
1005	AF	Pure tone is heard from channel 3 output.
1005	00	Channel 3 output is turned off.
1006	55	
1007	AF	Pure tone is heard from channel 4 output.
1007	00	Channel 4 output is turned off.

Audio Output Circuitry

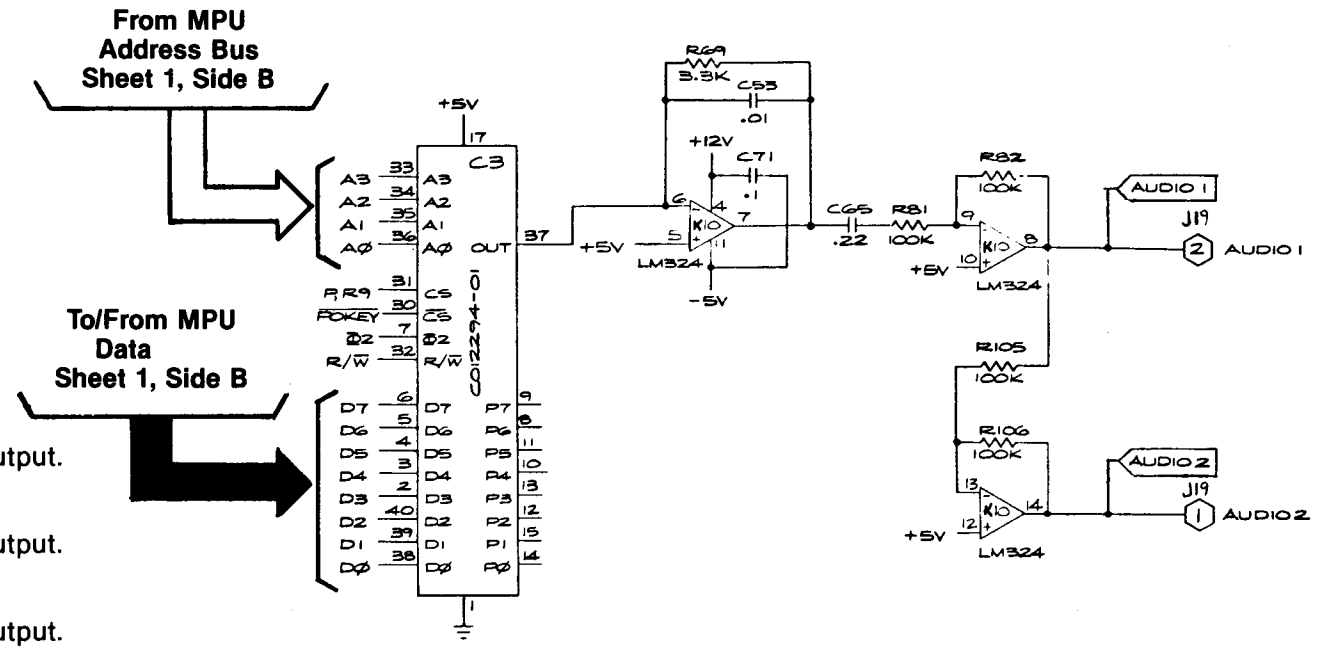

◀ Denotes a test point

The video output circuit receives motion object, playfield, address and data inputs and produces a video output to be displayed on the game monitor. In order to read out of the color RAM, GRY0 and GRY1 from the motion object circuitry are multiplexed with AREA0 and AREA1 from the playfield circuit by E8. The output, selected by GRY0 or GRY1, is RAMA0-RAMA3 (RAM ADDRESS).

RAMA0-RAMA3 are applied to color RAM C8. The colors red, green, blue and an alternate color bit are outputs. The three color bits are latched by A8 as the game video in the three basic colors (or shades of gray) in a black and white monitor). When the alternate color bit (C8 pin 11) is active, an alternate shade of blue or green is available.

The following conditions, along with the various combinations of COLOR 1 (red), COLOR 2 (green) and COLOR 3 (blue), provide 6 extra colors for a total of 14.

- If A8 pin 11 is low, transistor Q5 conducts and draws current from COLOR 3. The result is a pale blue when COLOR 1 and COLOR 2 are off.
- If A8 pin 10 is low, transistor Q4 conducts and draws current from COLOR 2. The result is a pale green when COLOR 1 and COLOR 3 are off.

Video Output Circuitry

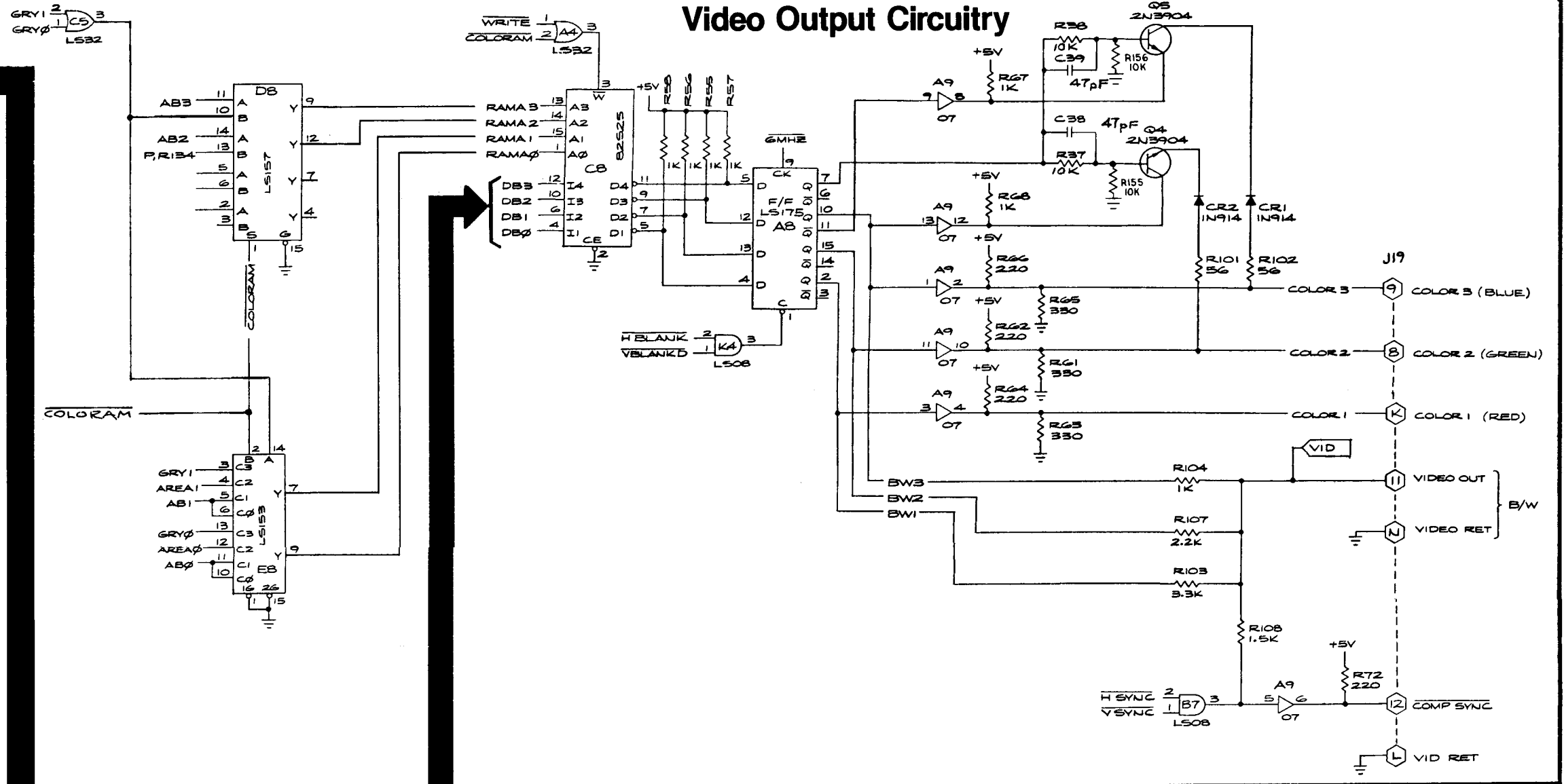

High Score Memory Circuitry

The High Score Memory circuit stores the three best scores and other pertinent information. These scores are saved even if power is removed from the game. The High Score Memory circuit consists of an erasable reprogrammable ROM E5, latches E4, H4, J4, buffer H5 and timer A11.

A11 produces a 0-15V square wave at a 1V rate. This signal, when +15V, forward biases diode CR5 and allows capacitor C86 to charge to -29V. When the signal is 0V, CR5 is cutoff and CR4 is forward-biased which causes C84 to develop a charge. C84 charges to approximately -28V. This is the potential required for EAROM C0 to operate.

The MPU addresses the EAROM (AB0-AB5) when a low EAADDR gates WRITE2 at gate A4. The trailing edge of the gated pulse latches the address information to the EAROM E5 via J4. Data is latched by H4 at the same time. The EAROM mode (read, write or erase) is determined by DB0-DB3 at latch E4. A low EACONTROL gates WRITE2 at gate A4. The trailing edge of this gated pulse latches the data into the EAROM E5 via latch H4.

Data is read from the EAROM when EAREAD on pin 1 of buffer H4 goes low.

From MPU Address Bus Sheet 1, Side B

