

004

008

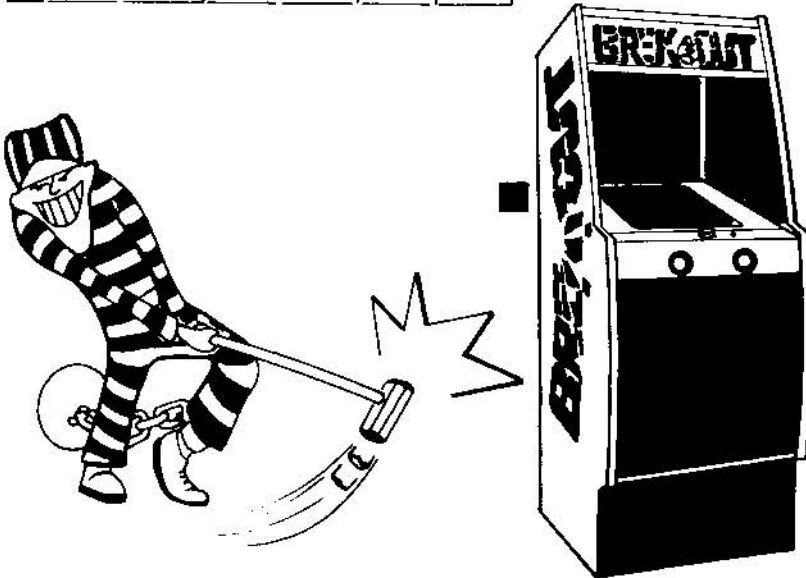
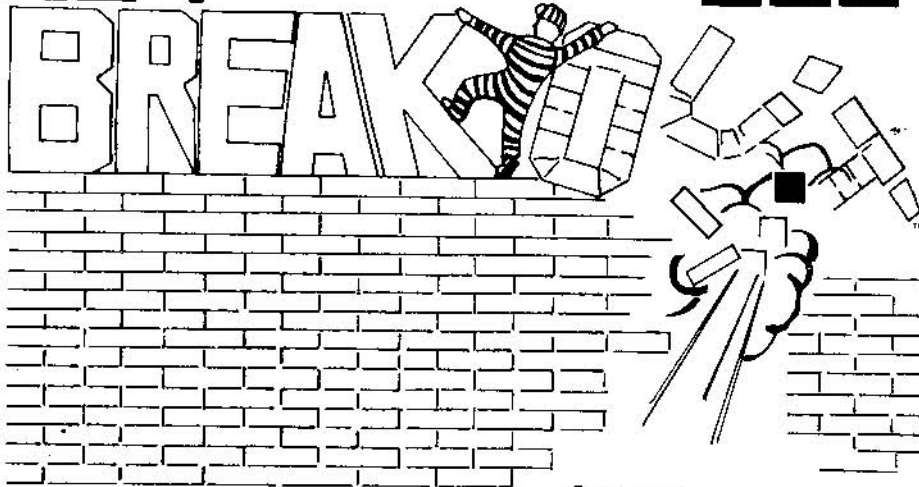

Operation · Maintenance Service Manual

Applicable for both upright and cocktail-table cabinets

Table of Contents

I.	INTRODUCTION	1		
1.1	Physical Description of Game	1	3.4.20	Brick Hit Sound Generator
1.2	Summary of Game Play	1	3.4.21	Paddle Player Controls and Paddle Generator
II.	SPECIFICATIONS	3	3.4.22	Numerals Display Generator
2.1	General	3	3.4.23	Sound Summing and Audio Out Driver
2.2	Electrical	3	IV.	INSTALLATION INSTRUCTIONS
2.3	Environmental	3	4.1	Unpacking Instructions
2.4	Owner/Operator Options for Structuring of Play	3	4.1.1	Examination for Shipping Damage
2.5	Accessories Available on Separate Order	3	4.1.2	Mechanical Inspection
III.	THEORY OF OPERATION	5	4.2	Energizing the Game
3.1	Functional Description of Game	5	4.2.1	Application of AC Power
3.2	General Information	5	4.2.2	Check on Operation of Interlock Switches
3.2.1	Energizing the Game		4.3	Game Structuring
3.2.2	TV Monitor		4.4	Functional Check of Game Operation
3.2.3	Picture on TV Screen		4.4.1	Check of Attract Mode
3.3	Game Sequence	5	4.4.2	Check of Play Mode
3.3.1	Operating Modes		V.	MAINTENANCE AND ADJUSTMENTS
3.3.2	Attract Mode		5.1	Routine Maintenance
3.3.3	Game Sequence in Play Mode		5.1.1	Cleaning
3.3.4	Owner/Operator Options		5.1.2	Lubrication
3.4	Detailed Technical Description of Operation	8	5.2	Adjustments on TV Monitor
3.4.1	General Information		5.3	Adjustment of Speaker Volume
3.4.2	Clock Generator		VI.	TROUBLESHOOTING AND REPAIR
3.4.3	Sync Countdown Chains		6.1	General Procedure
3.4.4	Picture Rotation Logic		6.1.1	Identifying the Trouble Area
3.4.5	Power Supply		6.1.2	Locating the Trouble Cause
3.4.6	Coin Recognition		6.1.3	Correcting the Trouble Cause
3.4.7	Q Latch and Antenna		6.1.4	Verifying Correct Game Operation
3.4.8	Start Recognition		6.2	Test Equipment
3.4.9	Free Game Selector		6.2.1	Basic Test Equipment
3.4.10	Credit Accumulator and Start Lamp Drivers		6.2.2	Optional Test Equipment
3.4.11	Brick Display		6.3	Specific Troubleshooting Information
3.4.12	Playfield Generator		6.3.1	Coin Mechanism
3.4.13	Points Counter		6.3.2	TV Monitor
3.4.14	Player Score Registers		6.3.3	Antenna Static Modification
3.4.15	Empty Wall Detector		VII.	SCHEMATICS, DRAWINGS, AND PARTS LISTS
3.4.16	Serve Wait			
3.4.17	Ball Serves Counter			
3.4.18	Ball Motion Counters			
3.4.19	Ball Hit and Motion Controls			

I. INTRODUCTION

1.1 PHYSICAL DESCRIPTION OF GAME

Atari's "Breakout" is a skill-based video action game designed for one or two players. The game is packaged in its own distinctively-styled cabinet that rests directly on the floor. Two cabinet versions, an upright cabinet and a cocktail table cabinet, are available. The upright cabinet has a 19-inch black-and-white TV monitor mounted behind an inclined transparent plexiglass panel. The monitor chassis is tilted back in a nearly horizontal position and the players stand in front, looking down at the screen. (Drawing number A004835 in Section VII of this manual shows an external view of this cabinet.) Several strips of colored transparent material are affixed to the glass on the front of the TV tube. During play these strips filter light coming from the screen so that certain portions of the TV picture will appear highlighted in color. One set of player controls and two "start" push buttons are mounted on a panel near the bottom end of the TV screen nearest the players. Two identical coin mechanisms also are mounted on the front of the cabinet, below the player controls. They accept quarters only and are connected so that either can initiate play. The cash box is located behind a locked access door to the coin mechanisms. A speaker is mounted in the top portion of the cabinet, above the TV screen. During play it produces a variety of sounds that add to the game excitement.

In the cocktail table cabinet the 19-inch black-and-white TV monitor is mounted beneath the table top, with its screen facing up. The TV tube is recessed below the table surface and a transparent plexiglass sheet protects it from damage. Two sets of player controls, one set near each end of the TV screen, are mounted on flat panels that are recessed into the table top. Two "start" push buttons are also provided, one along with each set of player controls. Two identical coin mechanisms are mounted halfway between the sets of player controls, on a side panel of the rectangular-shaped base that supports the table top. The cocktail table cabinet is provided with two speakers; each is mounted on a side panel of the base, below a set of player controls. The speakers are connected in parallel so that they both produce identical sounds. (Drawing number A005610 shows an external view of the cocktail table cabinet.)

1.2 SUMMARY OF GAME PLAY

"Breakout" is a ball-and-paddle game in which a player's objective is to build up the highest possible point score by hitting balls toward a wall of bricks. Each time a ball hits a brick, points are added to the player's score. Then the brick disappears and the ball rebounds. Bricks at the rear of the wall are worth more score points than those at the front. Player-accumulated scores are displayed continuously on the TV screen. Besides rebounding from bricks and from the player's paddle, the ball will also rebound from the play-field's two sidewall boundaries and from the backwall boundary behind the wall of bricks.

The player controls consist of a lighted "serve" push button and a "paddle" knob. Depressing the "serve" button causes a ball to appear on the TV screen and start moving toward the player. Twisting the knob causes the paddle to move back or forth along a straight-line path parallel to the end of the TV screen farthest from the wall of bricks. During play the player must manipulate the knob so that the paddle will move to a position that lies in the ball's path. If the player succeeds in doing this, the ball will hit the paddle and rebound back towards the wall of bricks. But if the player misses, the ball will pass by the paddle, continue on and finally disappear from the TV screen. To cause a new ball to appear the player must then depress the "serve" button again. The game only serves a preset number of balls, but the number of volleys made on any one ball is limited only by the player's skill.

Players will receive a large number of score points for a "breakout," that is, for clearing away an opening in the wall of bricks and then paddling a ball back through the opening. When this happens the ball rebounds back and forth between the backwall boundary and the high-value bricks, thus adding multiple points to the player's score for every brick hit. After a "breakout," the ball does not travel back toward the player's paddle until it finally rebounds back out through an opening in the wall of bricks.

To make the game more challenging for skillful players, during any one serve the ball speed increases in steps as the player makes more and more volleys, and it immediately increases to the fastest speed as soon as a brick on the back rows of the wall is hit. Besides these increases in speed, during any volley when a "breakout" occurs the width of the paddle is reduced to one half its normal size. The play sequence ends after the player misses a volley on the last ball served and that ball has disappeared from the TV screen.

The following three types of sounds are produced during game play as the ball hits various objects: a bounce sound when the ball hits the sidewall or backwall boundaries, a "blip" sound when it hits the paddle, and a "tick" sound for each score point when it hits bricks. A fourth buzzing sound is produced each time a player's score reaches a preset achievement level, provided that the game has been structured by an owner/operator option to allow bonus game credits.

In a two-player game, on the upright cabinet version the players take turns using the same set of player controls. On the cocktail table cabinet, each player has a separate set. The game's electronic circuitry includes a memory that "remembers" the brick pattern independently for each player. This feature insures that player 2 will not benefit from player 1's skill at making a "breakout" opening in the wall of bricks, and vice versa. On the cocktail cabinet version only, at the conclusion of each serve in a two-player game, the TV picture is rotated 180°. This is done so that the paddle end of the screen will be closest to the player whose turn it is to depress the "serve" button.

Section III of this manual gives additional details about the game play and describes the owner/operator options.

II. SPECIFICATIONS

3

2.1 GENERAL

Upright Cabinet Dimensions:	Height 65 1/4 in., Width 25 1/4 in., Depth 27 1/4 in.
Cocktail Table Cabinet Dimensions:	Height 30 in., Diameter of Table Top 33 1/2 in.
TV Monitor:	Motorola Model XM501, black and white, with 19-inch screen.
Coin Mechanisms:	Two identical mechanisms (connected in parallel); accept quarters only.
Cash Box:	Removable; located behind locked access door to coin mechanism assembly.
Power Cord:	Approximately 6 ft. long, extending from rear of cabinet and having grounded three-prong plug for conventional wall outlets.

2.2 ELECTRICAL

Power Requirement:	Uses conventional wall outlet providing 60-cycle AC (60 Hz, single phase) at 110 volts; power consumption rated at 210 watts.
Fusing:	All fuses located inside cabinet; TV monitor has two 1-amp fuses and remainder of game is protected by a 2-amp slow-blow fuse.
Power Interrupt Switches:	Upright cabinet has one switch located inside cabinet at access panel on rear. Cocktail table cabinet has three switches—one at side access panel, one beneath hinged table top, and one at

hinged access door to coin mechanism assembly. These are safety switches that interrupt AC power to the game whenever the panel is unlocked and opened, and, in the case of the cocktail table cabinet, also whenever the coin mechanism assembly access door is opened or the table top is unlatched and lifted up.

2.3 ENVIRONMENTAL

Operating and Storage Temperature Range:	from 32°F to 120°F (<i>Ambient Temperature</i>)
Relative Humidity:	from 0% to 80% <i>without</i> condensation

2.4 OWNER/OPERATOR OPTIONS FOR STRUCTURING OF PLAY

- Game Credits adjustable for either 1 credit/coin or 2 credits/coin.
- Number of ball serves adjustable for either 3 or 5 serves per play.
- Bonus Credit for high player score: choice of no credit, or one credit for attainment of preset level of points (adjustable in 100-point steps).

NOTE: A speaker volume adjustment is also provided.

2.5 ACCESSORIES AVAILABLE ON SEPARATE ORDER

Video Probe:	order from Atari
Universal Test Fixture:	order from Atari, catalog no. TF-101

III. THEORY OF OPERATION

3.1 FUNCTIONAL DESCRIPTION OF GAME

The block diagram in Figure 3-1 shows the major functional parts of the "Breakout" game and their interconnections. Note that the game printed circuit board sends a "composite video" signal to the TV monitor and a separate "audio" signal to the speakers. Only the cocktail table cabinet version has two speakers and two sets of player controls.

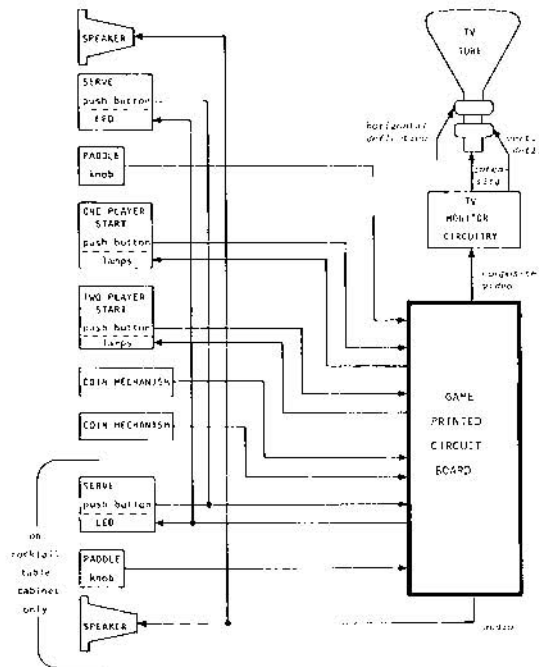

Figure 3-1 Functional Block Diagram of "BREAKOUT" Game

3.2 GENERAL INFORMATION

The general information about the "Breakout" game given here provides a background for understanding the Installation Instructions in Section IV of this manual, and the description of game operation in paragraphs 3.3 and 3.4.

3.2.1 ENERGIZING THE GAME: The game does not have an external "Power On" switch. Instead it is energized as soon as the power cord is plugged into an active AC wall outlet. This outlet must provide the AC power listed in the Specifications (Section II of this manual).

3.2.2 TV MONITOR: The game's TV monitor is a self-contained transistorized television monitor supplied to Atari by Motorola. Because the compo-

site video signal sent to the monitor by the game control circuitry differs in certain important respects from the signal derived from commercial TV broadcasts, the picture appearing on the screen is unlike that of a home TV set and the monitor does not produce any sound.

3.2.3 PICTURE ON TV SCREEN: The game's composite video signal is constructed to produce only two video levels (white and black), instead of the more or less continuous shades of gray seen on a home TV screen. Figure 3-2 shows a typical picture that would appear on the screen during play and identifies the objects in the picture. The score of the player up will be blinking on and off. The complete wall of bricks consists of 8 rows, with 14 bricks in each row. Four transparent strips, each a different color, are affixed to the surface of the picture tube so that each strip covers two rows of bricks. Drawing no. A004856 in Section VII of this manual shows a location diagram for the strips on the upright cabinet version and identifies the color of each strip. A fifth colored strip is placed over the narrow rectangular region of the screen in which the paddle is allowed to move back and forth. On the cocktail table cabinet two sets of brick strips are affixed, one set near each end of the TV tube, but the paddle strip is omitted. Two sets of brick strips are used because on this cabinet version the picture is rotated 180° after each serve in a two-player game.

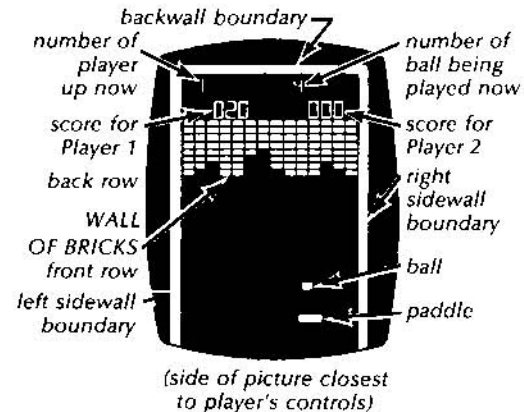

Figure 3-2 Typical Picture During Play

3.3 GAME SEQUENCE

3.3.1 OPERATING MODES: During use the "Breakout" game can be described as operating in either of two modes, attract or play. Plugging the power cord into an active AC outlet energizes the game and it starts out in the attract mode. The game remains in the attract mode until a player deposits a coin and the coin clears the coin mechanism, at which point a signal derived from the coin mechanism causes the game to go into the play mode. The game remains in the play mode until the

player misses a volley on the last ball served. The game then reverts back to the attract mode, unless one or both "start" push buttons are lighted.

3.3.2 ATTRACT MODE: Figure 3-3 shows a typical picture that would appear on the TV screen after completion of a play sequence in the play mode. After initial application of AC power the picture in the attract mode may vary somewhat from that shown in the figure; refer to paragraph 4.4 in Section IV of this manual for a description of the variations. In the attract mode the two player scores remain showing, but neither score will be blinking. The pattern of missing bricks (if any) will be the same as the pattern that was showing during the last moment in the play mode. No sounds are produced during the attract mode and neither "start" push button will be lighted.

A comparison of the pictures in Figures 3-2 and 3-3 will reveal the following differences between both modes. Within four seconds after the game reverts to the attract mode, a ball will automatically be served and will start moving toward the paddle end of the screen, and the number shown in the upper right corner of the screen will increase by 1. However, at the end of the screen closest to the player controls the single paddle has been replaced by a solid line that represents a full "row" of many paddles. Therefore the ball will always rebound off a paddle and change direction; the ball cannot disappear off the end of the screen.

In the attract mode, each time the ball hits against a brick it will rebound, but bricks will not disappear and the score numerals will not change. This continuous ball motion serves to attract the attention of potential players.

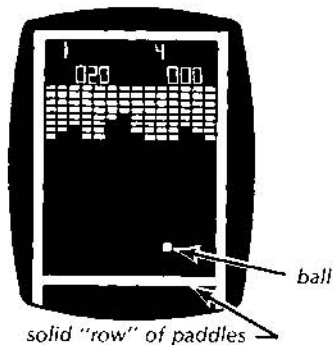

Figure 3-3 Typical Picture During Attract Mode

3.3.3 PLAY MODE: The game's circuitry has a credit accumulator that can keep track of as many as 15 game credits. One credit is subtracted from the accumulator at the beginning of a one-player game, and two credits are subtracted at the beginning of a two-player game. Just after initial application of AC

power the deposit of coins will cause credits to be added. A game owner/operator option can be set so that deposit of one coin adds one credit, or else so that it adds two credits. (The game's options are described in subparagraph 3.3.4.) During the first and subsequent play sequences one credit will also be added each time a player attains a preset bonus score level, provided that a second owner/operator option has been set to allow bonus credits. The game's two start push buttons are engraved with the words "One Player Start" and "Two Player Start," respectively. Lamps behind the one-player button light up whenever at least one credit is remaining in the credit accumulator, and behind the two-player button whenever at least two credits are remaining.

With credit in the credit accumulator, as the next step in play mode a player must depress a lighted start button. (Depressing a lighted start button later during a play sequence while a ball is appearing on the screen, or between ball serves, has no effect on game operation.)

The game then responds as follows:

- (a) Credit is subtracted from the credit accumulator.
- (b) If no credits are remaining in the credit accumulator, both start buttons go dark; if only one credit is remaining, just the "Two Player Start" button goes dark.
- (c) The picture on the TV screen changes. Specifically, the ball disappears, both scores are reset to all zeros, a full set of bricks (8 rows of 14 bricks each) is restored, a single paddle replaces the full "row" of paddles, the player up number is reset to "1," the ball number is reset to "1," and player 1's score begins to blink.
- (d) The serve push buttons light up. (Upright cabinet version has only one serve button.)
- (e) The paddle knob is enabled, so that twisting it will cause the paddle to move. (On cocktail cabinet version only one paddle knob will be enabled at a time.) However, no sound will be produced yet, and no ball appears on the TV screen.

As the next step a player must now depress a lighted serve button. (On the cocktail cabinet version both serve buttons are enabled; therefore only the player up should depress the button.) As the response to doing this, within four seconds or sooner a ball will appear about midway along the TV screen and will slowly move toward the paddle end of the picture. This is the slowest of four possible ball speeds.

The ball's initial direction will be random. Although one component of its direction will always be toward the paddle rather than toward the bricks, the ball may even hit a sidewall boundary before it reaches the paddle end of the picture. The ball is

never allowed to move in a direction exactly perpendicular to the front surface of the paddle, toward the bricks or to any of the boundaries. As soon as the first ball appears, the serve buttons go dark, but the ball number in the upper right corner of the picture remains at "1." On subsequent serves, however, the number will be increased by 1 each time a new ball appears.

With the ball moving on the TV screen, the player must now try to volley, that is, try to manipulate the paddle knob so that the paddle will move to a position that intercepts the ball before it escapes off the screen. If the player succeeds, the ball will rebound off the paddle and move back toward the wall of bricks. The "blip" sound will be produced whenever the ball hits the paddle, and the bounce sound whenever the ball hits a boundary.

Whenever the ball now hits a brick, that brick will disappear and the ball will rebound. But only one brick can disappear at a time; the ball must hit the backwall boundary or the paddle before another brick can disappear. A "tick" sound is produced to represent each point of the brick's score point value, as follows: Bricks in the first two rows nearest to the paddle are worth 1 point each; bricks in the next two rows are worth 3 points each; those in the next two rows 5 points each; and those in the two rows farthest from the paddle are worth 7 points each. Therefore the entire wall of bricks represents a total of 448 score points.

A serve ends right after the player fails to volley; the serve buttons light up as soon as the ball has disappeared off the end of the screen. To continue the play sequence a player must again depress the serve button. During two-player games the player-up number in the upper left corner of the picture changes from "1" to "2" after player 1 misses a volley, and vice versa. Each player in a two-player game receives an equal number of serves.

The play sequence continues as described above until all the balls set up by a third owner/operator option have all been served. If no credit is remaining in the credit accumulator at this time, then the game reverts back to the attract mode. But the game will remain in the play mode if one (or both) start buttons are lighted, because this means that credit is still remaining in the credit accumulator. After the game reverts to attract, it automatically "serves" itself a new ball and adds "1" to the ball number in the upper right corner of the screen. This ball cannot escape, however, because it cannot get past the solid row of paddles that appear in the picture in the attract mode.

Besides the slowest ball speed already described, during any one serve three speed-ups are possible. The first speed-up occurs upon the 4th hit, and a second, faster speed-up occurs on the 12th

hit. Ball speed changes to a fourth, fastest speed immediately after a high-point (either 5-point or 7-point) brick is hit, regardless of what it had been beforehand. Ball speed is restored to the slowest value at the beginning of each serve.

When the ball intercepts the paddle it will rebound in any of 4 directions, depending on which portion of the paddle was hit (see Figure 3-4). This is still the case even after the paddle has been reduced to half its normal width. Note that the ball is not allowed to move in a direction perpendicular to the front surface of the paddle, or perpendicular to the edge of the paddle.

If a player is skillful enough to knock away *all* bricks, as soon as the ball subsequently hits either the backwall boundary or the paddle a second full set of bricks will appear. The player can then earn additional score points by knocking away bricks in this second set. No extra serves are given however, and no additional bricks will be added after this second set. This feature means that the game's highest attainable score is limited to 896 points (two walls of bricks each worth 448 points).

After a "breakout" occurs and the ball has entered the region of the picture between the rear-most row of bricks and the backwall boundary, it does not interact with any of the score or other numerals. Instead it merely passes through them without any effect on its motion.

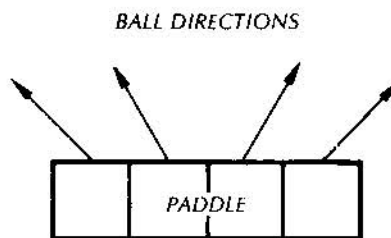

NOTES: 1) Angle of rebound is determined by which portion of the paddle that the ball hits. The ball's angle of incidence is irrelevant.

2) The angles of rebound become more perpendicular as ball speed increases.

3) The diagram above, with four sections, still applies after paddle width has been reduced to half the normal value.

Figure 3-4 Diagram of Ball Rebounds off Paddle

3.3.4 OWNER/OPERATOR OPTIONS: The "Break-out" game has three options which the owner/operator can adjust at the game site in order to structure the play sequence, that is to change some of the game rules or the duration of play. A fourth option allows the owner/operator to use a single type of game printed circuit board in both the upright and cocktail table versions of the game cabinet. Paragraph 4.3 in Section IV of this manual gives detailed instructions for adjusting these options. The game also has a speaker volume adjustment (refer to paragraph 5.3 in Section V).

(a) *Game Credits Option.* This option consists of a two-position switch. When in one position, the game is structured to add one credit into the credit accumulator each time a coin is deposited and clears the coin mechanism. When in the other position, two credits are added.

(b) *Bonus Credit Option.* This option consists of a miniature switch assembly having four switches. One combination of switch settings prevents the award of any game credits, regardless of the player score. The other combinations determine the score achievement level that a player must attain so that one credit will automatically be added into the credit accumulator.

(c) *Number of Ball Serves.* This option also consists of a two-position switch. One position allows a maximum of 3 balls to be served to each player per play sequence; the other position allows 5 balls.

(d) *Picture Rotation.* This option consists of another two-position switch; its position will be determined by the cabinet version in which the game PCB is installed. When the switch is in the position for the upright cabinet, the picture on the TV screen will never rotate. When in the other position, for the cocktail table cabinet, during a two-player game the picture rotates 180° after each serve is completed and the ball disappears off the screen. (After installation of the board in a cabinet this switch needs to be set only once.)

3.4 DETAILED TECHNICAL DESCRIPTION OF OPERATION

3.4.1 GENERAL INFORMATION: This subsection gives a technical description of the game's electronic circuitry. Drawing number 004533 is a four-sheet schematic diagram of the circuitry on the printed circuit board, and drawing number A004533 is the PCB assembly drawing showing the locations of the components called out on the schematic. The position of each integrated circuit device is identified by a column letter designation (A through N), and by a row number designation (1 through 9). Drawing number 004847 is a schematic of the harness wiring inside the game cabinet. These drawings

and a schematic diagram of the TV monitor's circuitry are included in Section VII of this manual.

On the PCB schematic the symbol *P* (appearing at various inputs to logic gates and other integrated circuits) indicates a connection to +5 volts through a pull-up resistor.

In the subparagraphs that follow, the portions of the circuitry being described can be located on the PCB schematic by finding the intersection of the zone letters (A, B, C or D) and the zone numbers (1 through 8). For example, the designation *Sheet 1, Zone A 8* refers to the extreme lower left corner of sheet 1 of the schematic.

3.4.2 CLOCK GENERATOR (SHEET 1, ZONES 7 & 8): The output of a 14-MHz crystal-controlled oscillator drives counter F1, which produces the signal CKSCO at its A output and CKBH at its B output. After gating the signal CLOCK is produced at H1 pin 11. These three timing signals provide the basic clock synchronization for the game circuitry.

3.4.3 SYNC COUNTDOWN CHAINS (SHEET 1, ZONES D 4 THROUGH 6): Counters L1 and K1 form the horizontal countdown chain, and M1 and N1 form the vertical countdown chain. They count down the CLOCK signal's frequency to produce the timing for the H SYNC and V SYNC signals. This timing forms the basis for the horizontal and vertical synchronization information sent to the TV monitor on the composite video signal.

3.4.4 PICTURE ROTATION LOGIC (SHEET 4, ZONES D 6 THROUGH 8): When structuring switch S2 is in the "normal" position (meaning that the board is installed in an upright cabinet), the PLAYER 2 CONDITIONAL signal is always low. But when switch S2 is in the "C/C" (cocktail cabinet) position the signal will go high only during a two-player game when player 2 is up. (The PLAYER 2 CONDITIONAL signal is produced at Gate H1 pin 3, as shown in Zone B3 on Sheet 2.) With the signal low (board in upright cabinet) the Exclusive-OR Gates M3, N3, L2 and K2 merely act as non-inverting logic stages and the timing of the 1V' through 128V' and 1H' through 128H' signals is not effected. But with the signal high, the Exclusive-OR Gates invert the timing signals coming from the sync countdown chains, and this inversion produces a 180° rotation of the picture on the TV screen.

3.4.5 POWER SUPPLY (SHEET 4 ZONE C 7): The connections from a 16.5 VAC tap on the power transformer provide the AC input for a full-wave rectifier power supply circuit based upon a type-LM323 amplifier. The +5 volts produced by the supply is used as the V_{cc} for the logic and other circuitry. The +V UNREG connects to the type-LM380 amplifier in the audio output drive stage (see Zone C 1 on sheet 2).

3.4.6 COIN RECOGNITION (SHEET 3, ZONES D 5 THROUGH 7): In each coin mechanism a coin switch is activated each time a coin passes through the mechanism and on into the cash box. The inverter latches “debounce” the signals produced at the switch contacts; the CSW1 and CSW2 signals cause the coin counter, an electromechanical counter inside the coin mechanism assembly, to advance by one count each time a coin is deposited into the game. The flip-flop stages F8 and F9 produce the COIN#1 and COIN#2 signals that set the Q latch when a coin is deposited. The remaining portion of the circuit discriminates between one or two credits per coin, as determined by the position set on Switch S3. The COIN signal produced at L9 pin 6 is connected to the credit accumulator; each pulse causes the accumulator to add one count. Flip-flop H8 will test the COIN#1 and COIN#2 signals for a valid width.

3.4.7 Q LATCH AND ANTENNA (SHEET 3, D 4): Transistors Q1 and Q3 form a discrete component latch. Note that they are complementary—Q1 is PNP and Q3 is NPN. The two stable states of this latch are:

- (a) Latch reset, with *neither* transistor conducting (meaning that the game is in the attract mode)
- (b) Latch set, with *both* transistors conducting (meaning that the game is in the play mode).

This latch is made to power on in its reset state. The first coin deposited into the game after initial application of power will set the latch, enabling credit and the start of the play sequence. This latch is normally reset after the player misses a volley on the last ball served, provided that *no* credits are remaining in the credit accumulator at that time. However the latch can also be reset if transistor Q2 goes into conduction. This should be the case only if a static spark occurs near the game and is received by the antenna that connects to the base of Q2.

3.4.8 START RECOGNITION (SHEET 3, ZONES C 5 THROUGH 8): The start push button switches connect to flip-flop E8, but the flip-flop cannot recognize a player’s depressing a button unless the game is in the attract mode. Also, depression of the “Two Player Start” is not recognized unless at least two credits are remaining in the credit accumulator. Latch F7 remembers which start push button had been depressed. The attract flip-flop E6 will remain in the “set” condition until it is reset at the end of the game sequence (the signal EGL and the signal Q).

3.4.9 FREE GAME SELECTOR (SHEET 3, ZONES A & B 5 THROUGH 8): This circuit compares the most significant bits in each player’s score register with the settings selected on switch S1. The J8 latches are each set if the player attains the bonus score level,

but this can only happen once per play sequence. Also a pulse is produced by the BONUS COIN signal after each latch is set. Each pulse will cause the credit accumulator to advance by one count. The BONUS COIN signal also triggers Multivibrator N8, so that the FREE GAME TONE signal will cause the speaker to produce the buzzing sound.

3.4.10 CREDIT ACCUMULATOR AND START LAMP DRIVERS (SHEET 3, ZONES A & B 2 THROUGH 5): The binary up/down counter L8 serves as the credit accumulator. The tie-back connection between pins 12 and 11 prevents the counter from advancing past a count of 15. The counter’s outputs are decoded to produce the 2 CREDIT and 1 OR 2 CREDIT signals which are used to turn on the gates of the silicon controlled rectifiers Q4 and Q5, and elsewhere in the circuitry. When conducting, each SCR provides the filament current for the lamps behind a start switch. The credit accumulator is decremented by the 1 CR START and 2 CR START signals produced when a player depresses a lighted start push button.

3.4.11 BRICK DISPLAY (SHEET 1, ZONE D 7): The memory capacity of the RAM device in location L3 is divided in half so that the brick pattern for each player is stored independently. At the very start of a play sequence a full brick pattern is restored for each player by the SET BRICKS signal. As play progresses, the time coincidence of the BRICK HIT signal with the 4H through 16H and 16V through 128V timing signals will determine which bricks are eliminated from each player’s brick pattern. The output signal from this circuit, BRICK DISPLAY, is combined in the playfield generation circuit with the other signals for the stationary objects in the TV picture.

3.4.12 PLAYFIELD GENERATOR AND VIDEO SUMMING (SHEET 1, ZONES C 5 AND D 3 AND 4): The sidewall and backwall boundaries are derived from the timing signals produced in the sync countdown chain, and are then combined with the BRICK DISPLAY signal to produce the PLAYFIELD signal at Gate H4 pin 3. The composite video signal to the TV monitor is produced at the summing point formed by the junction of resistors R41, R42, R43, R51, R52 and CR6. The horizontal and vertical TV synchronization information is coupled through CR6, the ball through R43, and the paddle through R41.

3.4.13 POINTS COUNTER (SHEET 2, ZONE C 5): Counter N9 is forced to parallel-load information when the BRICK HIT signal triggers multivibrator N8. The counter then counts down to zero at a rate set by the SCLOCK signal. The pulses produced at N7 pin 11 are used to drive the brick sound generator circuit, so that a distinct audible “tick” sound will be produced for each point value of the brick right after it has been hit by the ball. After gating in N7, the COUNT 2 signal is produced that drives the score register for player 2, and also the COUNT 1 signal for player 1’s score register.

3.4.14 PLAYER SCORE REGISTERS (SHEET 2, ZONES D 6 THROUGH 8): The BCD counters N6, M6 and L6 form a score register for player 2, and H6, J6 and K6 form one for player 1. Both registers are reset to all zeros at the beginning of each play sequence. Pulses of the COUNT 1 signal increment the player 1 register and those of the COUNT 2 signal increment the player 2 register.

3.4.15 EMPTY WALL DETECTOR (SHEET 2, ZONES D 4 & 5): The signals K₁, G₁ and D₁ are produced in the player 1 score register, and the signals K₂, G₂ and D₂ are produced in the player 2 score register. After a player has knocked away *all* the bricks flip-flop F4 is set as soon as the ball hits either the paddle or the backwall boundary. This can happen only once per play sequence; the flip-flop is reset only at the beginning of a play sequence. For player 1 the FPD₁ signal will cause the RAM in location L3 to restore a full set of bricks for player 1 only. The FPD₂ signal will do this for player 2.

3.4.16 SERVE WAIT (SHEET 1, ZONES A 1 THROUGH 3): After the ball disappears off the end of the screen flip-flop A3 is set via A3 pin 10, and the SERVE WAIT signal goes high. Also the LED inside the serve push button lights up. Now, no new ball can appear on the screen until a player depresses the serve button, thus forcing the SERVE signal to low. The circuit is disabled during the attract mode.

3.4.17 BALL SERVES COUNTER (SHEET 1, ZONES B, C 1 & 2): During a two-player game a pulse is produced at gate D2 pin 8, PLAY CP, after the SERVE WAIT signal (applied at pin 3 of flip-flop A5) goes high. During a one-player game two pulses in quick succession are produced. These PLAY CP pulses increment binary counter B4, the ball serves counter. The state of the counter's pin 14 least significant bit output, the signal PLAYER 2, tells which player is up. When pin 14 is low it means that player 1 is up, and when it is high player 2 is up.

The counter's other three outputs, BALL # A, BALL # B, and BALL # C, are decoded to produce the EGL (End of Game Level) signal. The position selected on Switch S4 will determine whether EGL goes high after 3 ball serves or after 5.

3.4.18 BALL MOTION COUNTERS (SHEET 1, ZONES B & C 6, 7, 8): Counters C7 and C8 form an X-direction ball motion counter, and B7 and B8 form a Y-direction ball motion counter. The X direction is defined as along the long dimension of the picture, and the Y direction as along the short dimension. Both counters are driven by the CLOCK signal, but they operate independently from the counters in the sync countdown chain. On the motion counters the number of clock pulses required to reach terminal count is dependent upon what parallel data has been preset into the counters. The parallel data for counter C7 is the signals CX0, CX1 and X2; for

counter B7 they are Y₀, Y₁ and Y₂. These signals are produced in the ball motion controls circuit. The counters reach terminal count once per picture frame. The ball motion is accomplished by changing the time when the counters begin counting. The ball speed is accomplished by changing the number of equivalent counts in the preset parallel data. The signals BRICK SOUND, VB HIT SOUND and P HIT SOUND are tapped off the counters as convenient waveforms for use in producing the tick, bounce and blip sounds. Outputs from the ball motion counters are decoded to produce the BALL signal.

3.4.19 BALL HIT AND MOTION CONTROLS (SHEET 1, ZONES A, B, C 3 THROUGH 7): Data is clocked into flip-flop E6 to produce a BRICK HIT signal each time the ball hits a brick. The BP HIT signal is produced when the ball hits the paddle; the BTB HIT is produced when the ball hits the backwall boundary; and the VB HIT is produced when the ball hits either sidewall boundary. Latch F7 is set when the ball hits a brick, but is not reset until the ball hits either the paddle or the backwall boundary. This action of the latch insures that only one brick hit is recognized at a time.

The state of flip-flop D5 (pins 5 and 6) determines whether the ball will move toward the backwall or toward the paddle end of the screen. The states of flip-flops A6 pin 8 and A6 pin 6 affect the angle of rebound when the ball strikes an object. Counter B5 is the volleys counter. Its outputs are decoded so that ball motion will be speeded up after 4 successive volleys during any one serve, and speeded up still more after 12 successive volleys.

Flip-flop D5 pin 9 detects when either a 5-point or a 7-point brick has been hit during any one volley. The flip-flop's output signal SU causes counter B5 to parallel-load all 1's, and the ball speed will then be immediately increased to its fastest value.

3.4.20 BRICK HIT SOUND GENERATOR (SHEET 2, ZONES C & D 1 THROUGH 3): The rate at which the SCLOCK signal increments the game's points counter N9 (subparagraph 3.4.13) is much too high for use in producing audible tick sounds directly. For this reason the COUNT signal is applied to a brick sound generator circuit in order to produce a slower rate signal.

Up/down counter F6 is preset to all 1's at the start of a play sequence. The brick hit point count pulses of the COUNT signal increment the counter F6 at a very high rate and also set latch F7. The signal produced at J9 pin 12, by gating the latch output with V SYNC and multivibrator A7's output, then decrements counter F6 back down at a very slow rate. This same signal also triggers multivibrator A8 at pin 11.

With this arrangement multivibrator A8 produces an output each time counter F6 is dec-

rement. These outputs cease after counter F6 underflows, because the counter's borrow output will then reset latch F7.

3.4.21 PADDLE PLAYER CONTROLS AND PADDLE GENERATOR (SHEET 2, ZONES A & B 1 THROUGH 4): Each player's paddle knob is attached to the shaft of a potentiometer connected to +5 volts. The potentiometer wiper arms connect to a type-4016 CMOS quad bilateral switch. During a two-player game on the cocktail table version of the game the PLAYER 2 CONDITIONAL' signal (and its complement at E9 pin 8) controls the analog switches so that either the connection between D9 pins 10 and 11 is closed and that between pins 8 and 9 is open, or vice versa, depending on which player is up. The upright cabinet version has only one paddle knob, and so D9 pins 11 and 10 are closed all the time.

The paddle potentiometers form part of the RC network that determines the charging time of a 2.2 microfarad capacitor in the input circuit of timer C9. The duration of the timer's output signal will determine how far the paddle will appear from the sidewall boundary.

During a serve when the ball hits the backwall boundary, meaning that a breakout has occurred on that serve, the BTB HIT signal clocks into flip-flop F5 and counter D4 is incremented. When this happens the paddle size is reduced to one half its normal width. The PAD signal is produced at K3 pin 8 after gating with the paddle window timing signals from the horizontal sync countdown chain.

3.4.22 NUMERALS DISPLAY GENERATOR (SHEET 2, ZONES A & B 3 THROUGH 8): The type-9312 one-of-eight data selector/multiplexers N5, M5, L5 and K5 receive player score data (separately for each player), ball serve number data (BALL # A, BALL # B, and BALL # C), and player number data. All multi-

plexers are strobed by the same timing signals from the sync countdown chain. The type-7448 device in J5 changes the BCD format multiplexer outputs into the 7-segment numerical format displayed on the TV screen. The multiplexers H5 and J5 then separate the 7-segment data into horizontal and vertical components, respectively, so that the data appears serially at H4 pin 11.

The gating configuration shown in Zone A5 generates the timing window that determines where the numerals will appear on the screen. The SFL (score flash) signal produced by the type-555 device in location B2 causes the player up's score to blink during a play sequence. The resulting SCL signal is clocked through flip-flop D3, which acts an inverter, to produce the SCORE signal.

3.4.23 SOUND SUMMING AND AUDIO OUT DRIVER (SHEET 2, ZONES C & D 1 THROUGH 3): The junction of resistors R36 through R38 forms a summing point for the signals that contribute to the game's sounds. R36 couples the signal produced by gating P HIT SOUND (from the ball motion counters) with the pin 6 output of multivibrator A8. This multivibrator is triggered each time the ball hits the paddle. In a similar fashion, R38 couples the signal produced by gating multivibrator A8's pin 10 output with BRICK SOUND. This multivibrator is triggered once each time counter F6 is decremented, so that a separate tick sound is heard for every point value when the ball hits a brick. R37 couples the signal produced by gating multivibrator A7 with VB HIT SOUND so that the bounce sound is heard when the ball hits the backwall or either sidewall boundary.

Potentiometer R50 couples the sound summing point to the output drive stage formed by the type-LM380 amplifier circuit. This potentiometer provides the manual speaker volume adjustment described in paragraph 5.3 of Section V of this manual.

IV. INSTALLATION INSTRUCTIONS

13

4.1 UNPACKING INSTRUCTIONS

4.1.1 EXAMINATION FOR SHIPPING DAMAGE: Before shipment from the factory, components and sub-assemblies of each game are carefully checked for proper operation. However, during shipment some adjustments may have changed or parts may have been damaged. Upon initial removal of the game from the shipping container, first examine the exterior of the cabinet. Then open the rear (or side) access panel and also examine the interior. Any shipping damage such as a dented, cracked or broken cabinet, sub-assemblies broken loose, etc., should be reported immediately to the shipper and to Atari, Inc.

4.1.2 MECHANICAL INSPECTION: After determining that the game has been received in good condition, carefully inspect the interior parts and verify the following:

- (a) All slip-on and plug-in connectors are firmly seated (particularly the PCB edge connector)
- (b) The fuses are all seated in their holders
- (c) No loose foreign objects are present (especially metal objects which could cause electrical short circuits)
- (d) No harness wires have become disconnected or pulled loose.

Be sure *all* major assemblies have been checked: game PCB, the transformer and other components on the electronics tray assembly, the two coin mechanisms, the speakers (only one on upright cabinet version), the player controls and start push button switches, and the TV monitor chassis.

Do not go on to the remaining paragraphs in this section until the above mechanical inspection has been thoroughly performed.

4.2 ENERGIZING THE GAME

4.2.1 APPLICATION OF AC POWER: Close and lock the access panel, making sure that it is completely shut at the bottom, and remove the key from the lock. On the cocktail table cabinet version also make sure that the table top is fully folded down into its normal, horizontal position and that the coin mechanism access door is fully closed. Then plug the power cord into an AC outlet providing the AC power listed in the Specifications (Section II of this manual). The wall outlet must accept a three-prong plug and the receptacle must be connected to a good earth ground.

After the power cord has been plugged in, the proper response from the game is that a picture appears on the TV screen.

If there is no response at all from the game, unplug the power cord and check the AC wall outlet. A simple, safe way to check for presence of AC power

at the wall outlet is to plug in an appliance known to be working properly—such as a table lamp, radio, or an electric clock. If the wall outlet passes the check, then presume that the trouble is with the game and refer to Section VI of this manual.

CAUTION: No troubleshooting steps should be attempted inside the cabinet by anyone not familiar with safety measures and repair procedures on electrical equipment.

Do not go on to the remaining paragraphs in this section until the proper response described above has been observed.

4.2.2 CHECK ON OPERATION OF INTERLOCK SWITCHES: The interlock switches are safety switches mounted inside the game cabinet. The upright cabinet has one switch near the bottom edge of the rear access panel. At the factory this switch is mechanically adjusted so that it will automatically transfer to its "off" position (switch contacts "open") whenever the panel is opened. When the interlock switch is in its "off" position, the AC power leading to the game's power supply is interrupted. When the panel is closed, the interrupt switch is adjusted to be in the "on" position (switch contacts "closed") and AC power is allowed to reach the game's power supply, meaning that the game can operate.

The cocktail table cabinet has three interlock switches, one near the bottom edge of the side access panel, one just beneath the folding table top on the side farthest from the hinges, and one on the coin mechanism assembly near the hinge of the access door. At the factory these switches are mechanically adjusted to transfer to "off" if the side panel is opened, if the table top is lifted, and if the coin mechanism access door is opened, respectively. When *even one* of these switches is in the "off" position, the AC power is interrupted.

After application of AC power per paragraph 4.2.1 above, correct operation of the access panel interlock switch on both cabinet versions can be checked as follows: unlock and slowly open the panel. The correct response is that by the time the edge of the panel has moved about 2 to 3 inches away from the cabinet the TV screen should go dark, verifying that the interlock switch has automatically transferred to "off." While opening the panel do not insert fingers inside the cabinet and do not allow foreign objects to fall inside. If the TV screen continues to be lighted up even after the panel has been opened, immediately close and lock it and unplug the power cord from the wall outlet. Then refer to Section VI of this manual to replace and/or adjust the interlock switch.

On the cocktail table cabinet the other two interlock switches must also be checked, *one at a*

time, after application of AC power. To check the switch near the coin mechanism assembly unlock the coin mechanism access door and swing the door all the way open. The correct response is that the TV screen should go dark before the door has reached its fully open position. Next close and lock the door. Doing this should restore AC power and the picture will reappear on the TV screen. To check the switch beneath the table top again unlock and open the coin mechanism access door.

After the door is opened and after the screen has gone dark, reach inside the cabinet and pull down on the spring-loaded chain that connects to the table top lock bolts holding the table top in place. While still pulling down on the chain, use the other hand to raise the table top up by about 3 or 4 inches. Now keep holding up the table top but with the other hand release the chain, pull the hand out, and close and lock the coin mechanism access door. The TV screen should now remain dark, even though the access panel is in place and the coin door is closed. Then lower the table top and push it fully down so that both spring-loaded lock bolts can be heard snapping into place. The correct response is that a picture will appear on the TV screen only when the table top is fully locked into place.

Do not go on to the remaining paragraphs in this section until the operation of all interlock switches has been checked and found to be correct.

4.3 GAME STRUCTURING

Before putting the game into operation at the game site, the game structuring should be defined by the owner/operator. The term "game structuring" refers to the game rules and the duration of the play sequence. Paragraph 3.3.4 of Section III in this manual covers the owner/operator options featured in this game and describes how they affect the game structuring.

In the "Breakout" game all structuring is accomplished by selecting positions on various switches mounted on the game printed circuit board. To do this the board has to be removed from its metal enclosure and then the switch positions have to be adjusted by hand.

Before performing any adjustment, the game should be de-energized or not operating. Further, it is also recommended that the power cord be unplugged beforehand.

Unlock and open the rear panel access door; doing this should cause the interlock switch to de-energize the game, as described in paragraph 4.2.2. If the switch fails to de-energize the game, immediately close and lock the door, unplug the power cord, and refer to Section VI of this manual to adjust and/or replace the switch.

While being careful to avoid touching any parts of the body against the TV chassis components or other wiring connections inside the cabinet, find the metal enclosure that houses the game PCB. Then unplug the edge connector to the RF board on the front of the enclosure, carefully noting how the connector plugs in. (It must be reconnected *in exactly the same way* after the switch positions have been changed.) Next remove the screws holding the RF board onto the enclosure and unplug the RF board from the game PCB. Now the game PCB has been freed so that it can be slid out of the enclosure far enough to allow access to the switches. Examine the surface of the board and identify the switches shown in Figure 4-1. (Their exact locations are shown on the PCB assembly drawing, drawing number A004533 in Section VII of this manual, with designations S1 through S4; the volume adjustment potentiometer is designated R50.) Figure 4-1 also shows the letters and numerals engraved on the surface of the board alongside each switch.

(a) *Game Credits Switch.* Slide the stud on top of the switch body all the way towards "1/P" to structure the game for 1 credit/coin, and towards "2/P" for 2 credits/coin.

(b) *Bonus Credit Switch Assembly.* Each of the four two-position switches can be independently set to either an "on" or "off" position. Table 4-1 shows the correct setting of each switch to structure the game so that no bonus credits will be given, and other settings to allow one bonus credit upon achievement of a given score level. A setting for either 200 or 300 points is recommended.

(c) *Number of Ball Serves Switch.* Slide the stud all the way towards "3B" to structure the game for 3 ball serves per player, and towards "5B" for 5 ball serves.

(d) *Picture Rotation Switch.* Slide the stud towards "NORM" when the board is installed in an upright cabinet, and towards "C/C" when in a cocktail table cabinet.

After the desired structuring has been set up, slide the game PCB back into its enclosure and plug the RF board back on to the game PCB. Replace the RF board on the front of the enclosure and secure it in place. Then replug the edge connector back onto the RF board, *making sure* that it is reconnected in the way originally found.

After performing these adjustments, close and lock the side panel, and energize the game.

4.4 FUNCTIONAL CHECK OF GAME OPERATION

The following procedure provides a simple

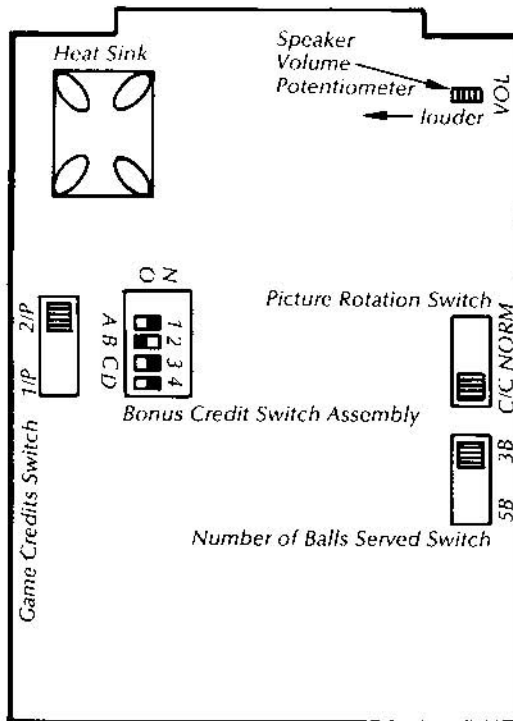

NOTE: Component side of board shown; not drawn to scale.

FIGURE 4-1: Approximate Locations of Game Structuring Switches and Speaker Volume Adjustment

check that can be quickly performed at the game site and that does not require external test equipment. If at any point during this procedure the game's response is found to be other than that called for herein, assume the game is not operating correctly and refer to Section VI of this manual. If responses are as described here then assume that major parts of the game are operating correctly. First perform the adjustments described in paragraph 4.3, Game Structuring, and then energize the game (paragraph 4.2). Just after application of power a picture should appear on the TV screen and the game should be operating in the attract mode as per subparagraph 3.3.2.

4.4.1 CHECK OF ATTRACT MODE: No sounds should be produced during the attract mode. The picture should resemble the one shown in Figure 3-3, with the ball continually moving about within the boundaries. Occasionally upon initial application of power, certain variations in the picture may be noted. More rarely the variations may occur later, after one or more play sequences, if either static charge on the antenna or severe noise spikes on the

Switch Settings				GAME STRUCTURING
"1" (A)	"2" (B)	"3" (C)	"4" (D)	
off	off	off	off	No Bonus Credit Given
on	off	off	off	One Bonus Credit for achievement of:
off	on	off	off	100 point score
on	on	off	off	200 point score
off	off	on	off	300 point score
on	off	on	off	400 point score
off	on	on	off	500 point score
on	on	on	off	600 point score
off	off	off	on	700 point score
off	off	off	on	800 point score

NOTE: Do not use switch settings other than those shown above because it is impossible for a player to attain a score level of 900 points or higher.

Table 4-1 Settings on Bonus Credit Switch

AC power line reset the game's credit circuitry.

An example of a picture variation is that one or more numeral positions in a score display may be entirely blank, or some random, unattainable score may be showing. Variations in the brick pattern can range from no bricks at all to a full set. Variations in ball motion can include a case where the ball passes through the entire brick wall without any interaction with individual bricks, and a case where the ball is "trapped" in the region behind the brick wall. *These kinds of picture variations do not mean that the game is operating incorrectly.* A more normal attract mode picture will appear on the screen after the conclusion of at least one subsequent play sequence in play mode.

During the attract mode all player controls should be disabled and all the backlighted push buttons should be dark. (At the very beginning of attract just after a play sequence has ended, serve push buttons will light up momentarily but within four seconds will go dark and remain dark when the game has automatically served itself a ball.)

4.4.2 CHECK OF PLAY MODE: After correct game operation in the attract mode has been verified, deposit a coin in one of the coin mechanisms. As soon as the coin has been accepted, the game should respond as follows: If structured for 1 credit/coin the "One Player Start" button should light up and the

"Two Player Start" should remain dark. If structured for 2 credits/coin both start buttons should light up. The picture should remain the same as it was before the coin was deposited, and still no sounds should be produced.

Depress the "One Player Start." If "Two Player Start" had been dark then the "One Player Start" should also go dark. If "Two Player Start" had been lighted previously, it should now go dark but "One Player Start" should remain lighted. The other responses, changes in the picture and enabling of the player controls, should be as described in (c), (d), and (e) of subparagraph 3.3.3. However, no sound should be produced yet and no ball should appear on the TV screen.

Depress the lighted serve button. The response to doing this should be as described in subparagraph 3.3.3. After that ball has disappeared off the edge of the screen the "SERVE" should light up

again. For the remainder of the play sequence exercise the player controls to verify correct operation of the various game features (sounds, ball motion, scoring, bonus credits, etc.). Confirm that the play sequence ends after the last ball served has gone off the edge of the screen.

For the final part of the check set up and play a two-player game sequence. Deposit a coin in the other coin mechanism. (If the game is structured for 1 credit/coin, two coins must be deposited). Then depress the lighted "Two Player Start" button. A two-player game should now commence as soon as the lighted serve button is depressed. In the cocktail cabinet version the two sets of player controls should be enabled, one set at a time, alternately after each ball serve. Also the picture should rotate by 180° in a two-player game.

The check is completed after correct operation in a two-player game has been verified.

V. MAINTENANCE AND ADJUSTMENTS

5.1 ROUTINE MAINTENANCE

Due to its solid-state electronic circuitry, this Atari game should require very little maintenance and only occasional adjustment.

5.1.1 CLEANING: Game cabinets and glass may be cleaned with any non-abrasive household cleaner. If desired, special coin machine cleaners which leave no residue can be obtained from distributors.

5.1.2 LUBRICATION: About once every three months lightly spray the rejector linkage portion of the coin acceptor inside each coin mechanism. Use WD-40® or similar lubricant, and *avoid* spraying the entire coin acceptor. Potentiometer shafts must never be lubricated in any way.

5.2 ADJUSTMENTS ON TV MONITOR

The TV monitor need be adjusted *only* when the picture is distorted, or if the contrast or brightness seem out of adjustment.

NOTE: The TV monitor is accessible only from inside the game cabinet and these adjustments have to be done while the game is energized. Therefore only persons familiar with safety measures and repair procedures on electrical equipment should perform them.

The monitor's adjustments function like those of a conventional commercial television set, except that the volume adjustment has no effect. Instead the game produces its sound in a speaker separate from the TV monitor. Figure 5-1 shows the location of the adjustments on the rear of the chassis. When making the adjustments follow these general guidelines:

- BRITE (Brightness)**—Perform this adjustment before the contrast. Adjust so that the white lines covering the screen just barely disappear, when the brightness is turned up.
- CONT (Contrast)**—Adjust so that the images are as bright as possible against the dark background without being blurred.
- HORIZ HOLD (Horizontal Hold)**—Adjust if the picture is slightly off-center horizontally, if the images appear warped, or if the picture is broken up into a series of diagonal lines. Adjust for a stable, centered picture.
- VERT HOLD (Vertical Hold)**—This needs adjustment only if the picture appears to be rolling up or down the screen. Adjust for a stable, centered picture.

5.3 ADJUSTMENT OF SPEAKER VOLUME

The speaker electronic drive circuit is provided with a potentiometer that controls the volume of sounds produced during play. This potentiometer is mounted on a printed circuit board inside the game cabinet and it can be manually adjusted to give the volume level desired. The following procedure tells how to make this adjustment.

For a game in the upright cabinet unlock and remove the access panel at the rear of the cabinet. On the cocktail table cabinet the access panel is on the side of the table base opposite from the coin mechanisms. Removing the access panel should cause the interlock switch to de-energize the game, as described in subparagraph 4.2.2. If the switch fails to de-energize the game, immediately replace and lock the panel, unplug the power cord, and refer to Section VI of this manual to adjust and/or replace the switch.

While being careful to avoid touching any parts of the body against the TV chassis components or other wiring connections inside the cabinet, find the metal enclosure that houses the game PCB. Unplug the edge connector that connects the wire harness to the RF board mounted on the front of the metal enclosure. Note how this connector plugs in; it must be reconnected in *exactly* the same way after the volume adjustment has been made. Next remove the screws that hold the RF board onto the front of the metal enclosure, and then unplug the RF board from the game PCB. The game PCB is now free to move out of the enclosure.

Slide the PCB on its guides until it is partway out and the volume adjustment potentiometer is accessible. Figure 4-1 shows its approximate location. (Its exact location is shown as R50 on drawing number A004533 in Section VII of this manual.) To increase speaker volume, move the stud on top of the potentiometer body in the direction shown by the arrow in Figure 4-1. To decrease speaker volume, move the stud in the opposite direction.

After making the adjustment, push the game PCB all the way back into the enclosure, replug the RF board onto the game PCB, and then secure it in place on the front of the enclosure. Next replug the wire harness edge connector back onto the RF board, *making sure* that it is reconnected in the way originally found. Then replace the cabinet panel and energize the game.

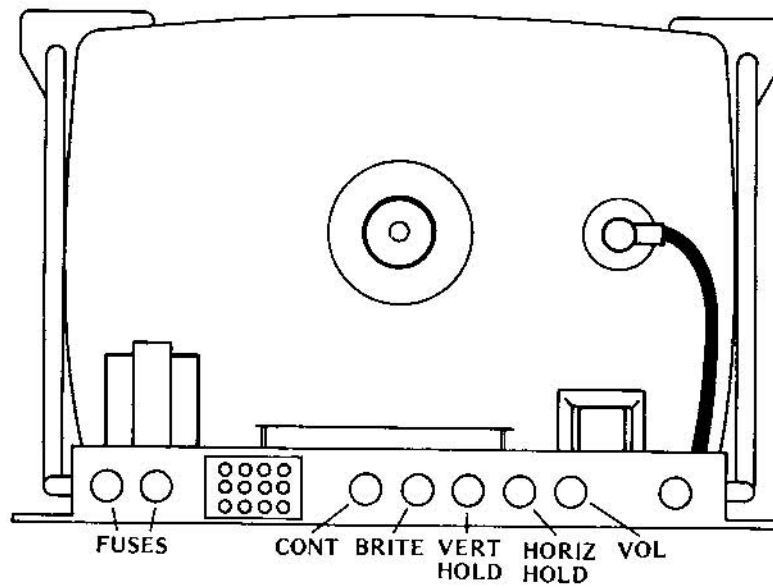

Figure 5-1 Location of Adjustments on TV Chassis

VI. TROUBLESHOOTING AND REPAIR

19

6.1 GENERAL PROCEDURE

NOTE: This section describes troubleshooting procedures in detail sufficient for a person with moderate technical ability to understand. However, for those interested in gaining more information on video game technology, especially the electronics, we recommend reading the Video Game Operator's Handbook, manual no. TM-043. This book is available from Atari, Inc., attn. Customer Service Dept., 2175 Martin Avenue, Santa Clara, CA 95050 for \$5.00 each, or from your distributor.

6.1.1 IDENTIFYING THE TROUBLE AREA: The first troubleshooting step should be to note all observable trouble symptoms. Examples of symptoms are: depositing a coin produces no game response, no sound coming out of the speaker at any time, no picture on the TV screen. At the same time also note the game features that still work. A systematic way of checking game operation is to perform the functional check given in Section IV of this manual. Carefully train your eye to pick up all clues; by doing this an experienced troubleshooter can often spot the cause of a trouble even before he opens the cabinet.

Keeping these observations in mind, use the understanding of game operation gained from the theory of operation (Section III) and the schematic drawings (Section VII). Next narrow down the suspected cause of the trouble to a specific area or areas of the game: the coin mechanism, TV monitor, harness and front panel components (switches, lamps, speaker), electronics tray, printed circuit boards and power cord. Be careful not to overlook possible trouble areas that may seem too obvious: a power cord plug that has worked loose from the wall outlet and is no longer fully seated in the receptacle, or a rear panel access door that is not fully closed (thus causing the interrupt switch to block the AC power path to the game).

6.1.2 LOCATING THE TROUBLE CAUSE: Once a problem has been narrowed down to one or more areas, the next step is to perform various tests and measurements to isolate a specific cause of the trouble. Remember that sometimes a very complicated problem, such as erratic game operation, can be traced to a simple cause—the printed circuit board not being fully seated in its edge connector. Start with the most suspect area and trace backwards from the point where the trouble is first observable, using a process of elimination to eventually locate the faulty component, connection, etc. For example, if no sound is audible during game play, first check for a signal at the speaker leads. If no signal is present there, go back through the wiring harness connections to the printed circuit board. If there is still no signal, then systematically check back through the various components of the sound generation circuit.

Substitution of parts is a legitimate and easy way to isolate the cause. For instance, if the PCB is the suspected trouble area, remove it and substitute a known-to-be-good PCB. Then check for correct game operation. Similarly, to check the TV monitor, connect the game to a known-to-be-good monitor. The harness can often be checked by substitution also. Substitute both a known-to-be-good PCB and TV monitor. If the trouble still persists, the harness must be at fault.

While locating the trouble cause, use the technical descriptions in Section III as guides for correct circuit-level operation, and the schematic drawings of Section VII as roadmaps for tracing signal flow paths.

The test equipment for use in troubleshooting is discussed in paragraph 6.2.

6.1.3 CORRECTING THE TROUBLE CAUSE: In practice, the steps required to correct troubles can range from simple adjustments (fully seating the PCB in its edge connector, changing the setting on a potentiometer, adjusting the picture controls on the TV monitor) to repair of loose connections and replacement of defective parts. Extreme care should be exercised when removing integrated circuit devices and discrete components. Use a 40-watt soldering iron with a small tip designed especially for IC work. To remove an IC device, follow this procedure:

Clip all leads and lift the IC package out, leaving two rows of leads. Then remove leads individually with a soldering iron and needle-nose pliers. Finally, evacuate the holes with a solder sucker. Afterwards clean the area thoroughly, using an approved PCB cleaning solution to remove any traces of flux and dirt. Alcohol will do in a pinch, if necessary.

Insert the new IC device using an IC insertion tool, making sure that the reference notch is oriented correctly and that the device's leads are not bent during insertion into the board. Afterwards, be sure to solder each lead on *both* sides of the PCB, using as little solder as possible. After soldering, clean the area thoroughly to remove the flux.

Observe the same removal and insertion procedures when replacing discrete components. Trim the leads as close as possible and be sure to orient diodes and capacitors correctly.

6.1.4 VERIFYING CORRECT GAME OPERATION: After locating and correcting the cause of a trouble, re-energize the game and perform a final check on correct game operation. Doing this will verify that your troubleshooting was correct. If the game operation is still not correct, go back and double-check your work. Make sure that any replaced compo-

nents were installed correctly. If this was done properly, then start the troubleshooting steps over again. Keep in mind that there may be more than one trouble at a time, and that correcting one trouble can sometimes bring previously undetectable troubles to light.

This verification is especially important when the original trouble had been intermittent, that is, was not happening all the time.

6.2 TEST EQUIPMENT

Electronic troubleshooting of a video game essentially consists of checking for the presence of various signals and of examining their condition. A signal can be thought of as acting like a "messenger" that carries instructions from one unit or circuit to another. Many different types of signals are produced in a video game, and for this reason several unusual and perhaps unfamiliar types of test instruments are used during troubleshooting. Each instrument has its own set of advantages and disadvantages for examining a given type of signal, and both the depth of the intended troubleshooting capability and budget will determine what instruments will be needed. Some instruments are basic and essential, no matter what size of service facility, while other optional instruments are desirable because they make troubleshooting easier and quicker.

6.2.1 BASIC TEST EQUIPMENT:

(a) *The Video Probe.* This is a simple but invaluable instrument having two leads—a test-clip lead and a test-probe lead. During troubleshooting of video signals the test-clip lead is left connected to the game side of the video coupling capacitor. On the Breakout game this point is the junction of resistors R41, R42, R43, R51 and R52 on the PCB. When the test-probe lead is then connected to any video developmental signal, that signal will be coupled to the video signal going to the TV monitor and a video probe picture will appear on the TV screen. The shape and other characteristics of this picture will give information about the signal being probed. The video probe is suited for troubleshooting synchronization and image signals, but will not be useful for extremely fast signals (such as the clock) or for very slow analog or digital signals.

A video probe can be constructed in a few minutes from these common electrical components: a length of 20 AWG (American Wire Gauge) rubber-coated wire, a 4.7K-ohm, ¼-watt carbon resistor, and two test leads. For the leads, use a single Mouser test clip (Mouser # 131C301 or 302) attached to one end of the wire, and a test prod containing the resistor on the other.

To assemble the video probe, proceed as fol-

lows: Remove the cap from the test clip and strip 3/16 inch off each end of the wire. Solder one end to the post in the test clip, thread the other end through the hole in the cap, and snap on the cap. Next unscrew the plastic body of the test prod from the point and trim both leads of the resistor to a 3/16-inch length. Solder one resistor lead to the inside of the point. Thread the other end of the wire through the hole in the body and solder it to the other resistor lead; screw the body back onto the point.

(b) *The Logic Probe.* This is a test instrument designed for fast verification of digital IC outputs. It is small, convenient to carry, easy to read, and relatively inexpensive. The logic probe derives its power from the system under test; it has two power leads, one for connection to ground and the other to +5 volts DC. When the logic probe's tip is held against a digital signal point, three colored lamps in the tip will indicate the signal's condition or state, as follows:

- The red lamp lit indicates a high or logic level 1 (for TTL components, this is +2.4 to +5 volts)
- The white lamp lit indicates a low or logic level 0 (for TTL components, this is 0 to +0.8 volt)
- The blue lamp lit indicates that the signal is changing states
- No lamps lit indicate the grey region between 0 and 1 (for TTL this is between +0.8 and +2.4 volts)

A circuit shorted to ground will illuminate the white lamp and an open circuit will illuminate the red lamp.

The logic probe is readily available from electronic supply sources; a commercial model found satisfactory is the Kurz-Kasch model LP 520.

(c) *The Logic Pulser.* This test instrument is similar in size and shape to the logic probe, and it also derives its power from the system under test. When the logic pulser's tip is held against a digital signal point, the source and sink capabilities of the pulser override any IC output and the point is driven to the opposite logic level. If the point that the logic pulser is held against is low, pressing the switch on the side of the pulser will introduce a high pulse. Conversely, pulsing a high line will pull that line low momentarily.

During troubleshooting the logic pulser allows stimulation of in-circuit ICs with a shaped digital pulse. For example, a certain feature of the game may not be working and you suspect that a circuit is not receiving the necessary signal. Use the pulser to imitate that signal: if the circuit begins working, you have proved that the signal was in fact missing and you can begin tracking it down. This technique is very similar to jumping coils in electromechanical games such as pinball machines.

In addition to the regular "pulse" button, there is another switch mounted on the logic pulser. When this switch is set in the "rep" mode, the instrument pulses the digital signal point at a 5-Hz rate or 5 times per second. This extremely low rate is slow enough to allow watching events initiated by the pulser. Counter outputs, for example, are more easily observed when the counter is pulsed or clocked at this rate.

The logic pulser is also readily available from electronic supply sources; a commercial model found satisfactory is the Kurz-Kasch model HL 583.

(d) *Oscilloscope.* The most versatile test instrument, and also the most expensive, is the oscilloscope. The high-speed TTL integrated circuits used in video games produce fast-rise-time signals. The oscilloscope should have a 50-MHz bandwidth, dual trace and dual time base capability. These latter features allow examination of both input and output signals simultaneously, so that precise timing relationships can be checked. The oscilloscope should also have provision for internal or external sync.

Of the newer, solid-state oscilloscopes, a satisfactory model is the Tektronix 465.

(e) *VOM or Volt-Ohmmeter.* This common measuring instrument is extremely useful in video game troubleshooting. It can be used to check line voltage, transformer secondary windings, continuity, resistance, power supply voltages, and to some extent used for measurements in the analog circuitry.

One commercial model found satisfactory is the Simpson 260.

6.2.2 OPTIONAL TEST EQUIPMENT:

(a) *The Logic Comparator.* This test instrument's main benefit is that it can be used to check the functioning of an integrated circuit device while the device is still in place on the printed circuit board. The logic comparator performs the check by comparing the suspect ICs functioning with that of an identical-type reference IC mounted in the instrument itself. Suppose that the functioning of a type-74193 device on the PCB is suspected to be defective. First insert a program card with a known-to-be-good 74193 into the logic comparator, and then clip the comparator test leads onto the leads of the suspect device. If there are any logic state differences between the reference IC and the suspect IC under test, then an LED on the logic comparator will light up to indicate which output is not functioning correctly. Once a defective IC has been located, it should be replaced.

Logic comparators are readily available from electronic supply sources.

(b) *Atari Universal Test Fixture.* In situations where a large number of video games are being serviced, investment in the Universal Test Fixture will be justified. This item of test equipment forms a test station for troubleshooting printed circuit boards after they have been removed from the game cabinet. The Universal Test Fixture has a full set of controls for operating the game and also has its own TV monitor. The game's PCB is plugged into an edge connector mounted on the side of the fixture; with this arrangement the PCB is positioned in a convenient way for connecting probes and other test instruments.

A program card inserted into a receptacle in the top of Fixture takes the place of the game's interconnect wires. The program card thus sets up the Fixture for each particular game; the game's name is clearly printed on the program card itself.

With the Universal Test Fixture the method of troubleshooting via substitution of known-to-be-good parts is made fast and convenient. For example, suppose that the TV picture in a game is completely broken up and you want to determine whether the game or monitor is causing the problem. Remove the PCB and plug it into the Fixture's edge connector, and also insert the correct program card for that game. If the picture on the Fixture's monitor is correct, then you know that the problem lies in the game's monitor.

6.3 SPECIFIC TROUBLESHOOTING INFORMATION

The following subparagraphs give additional troubleshooting information about certain areas of the Breakout game.

6.3.1 COIN MECHANISM: If a player inserts a coin and the game does not respond, first check the coin mechanism. If pressing the coin rejector button forces the rejector mechanism to return the coin, then examine the coin to make sure that it is genuine. If it is, then use a set of your own test coins (which should include both very new and very old, worn coins) to determine whether or not the player's coin is undersize or underweight. If your test coins are also returned, this indicates that servicing of the coin acceptor portion of the coin mechanism is called for. Generally the cause of this particular problem is an improperly adjusted magnet gate.

Inside the coin mechanism a magnet is used to test the metallic composition of the coin. Highly magnetic coins, such as those made of steel or iron, will be retained by the magnet and can be returned by actuating the wiper operating lever. Coins having comparatively high magnetic properties will be slowed down by the magnet, and will drop off the end of the rail short of the "accept" entrance and be

returned. Coins having little or no magnetic properties, such as brass or zinc coins, will pass through the magnetic field so fast that they will overshoot the "accept" entrance and be returned.

A magnetic gate adjusted with too large a gap may pass both genuine and counterfeit coins. An adjustment with too small a gap can lead to rejection of some or even all coins. Over a period of time, the screw that adjusts the magnet gate has a tendency to work loose, resulting in a gradual narrowing of the gate. At first, only the thickest (i.e., newest) coins are rejected. As time passes, more and more coins are rejected until finally player complaints lead to the calling of the game repairman.

If pressing the coin rejector button does not cause the coin to be returned, and if the game still does not respond, then check the coin mechanism to see if the coin is jammed inside.

If you are certain that the coin is genuine, and that the coin passes through the coin mechanism and into the cash box, then the lack of game response is probably due to some kind of electrical trouble. Check for signals at the electrical contacts of the coin mechanism before moving on to the harness and other parts of the circuitry.

6.3.2 TV MONITOR: The TV monitor is a self-contained unit housed in its own chassis. A trouble's cause may be narrowed down to the monitor—either by the substitution method using a known-to-be-good monitor, or by verifying presence of AC power to the monitor power supply and presence of the correct composite video signal. The entire monitor can then be removed from the game cabinet. Doing this facilitates troubleshooting steps, because all monitor components will then be accessible.

A schematic diagram of the monitor circuitry is included in Section VII of this manual. After discon-

necting and removing the monitor from the game, standard TV troubleshooting techniques are adequate for locating causes of trouble. Additional servicing information is available from the monitor manufacturer (Motorola).

6.3.3 ANTENNA STATIC MODIFICATION: This subparagraph gives a procedure for modifying the antenna wire connected to pin 17 of the printed circuit board's edge connector. The antenna is part of the credit portion of the game circuitry. This static modification feature is included so that it will not be possible for a player to obtain bonus games (that is, game plays without having deposited money into the game) by inducing a static charge in the coin entrance plate or any other metal part of the game—provided that the antenna has been cut to optimum length.

The antenna is a wire approximately one foot long, with one end intentionally left not connected. When a static discharge occurs, an electric current is induced in this wire and an impulse is transmitted to the credit latch circuit. This impulse resets the latch, turning off game credit and changing the game over to the attract mode. To test the static modification feature, touch the end of the antenna wire with your finger; the body usually has enough capacitance to trigger the circuitry. Sensitivity of the static modification feature can be adjusted by changing the length of the antenna wire. Lengthening the wire increases sensitivity, so that a lesser charge will turn off game credit. Cutting the wire shorter decreases sensitivity, so that a larger charge is required for triggering the circuit.

If there are problems with static charges accidentally shutting off the game credit, try cutting the wire shorter, in increments of ½ inch at a time. Be aware, however, that if the antenna wire is cut too short, players may be able to obtain free game credit (bonus games) by inducing a static charge in the game.

VII. SCHEMATICS, DRAWINGS & PARTS LISTS

23

<i>Number</i>	<i>Title</i>	
A004835	Parts List and Drawing Top Assembly	(Upright Cabinet)
A005610	Parts List and Drawing Top Assembly	(Cocktail Table Cabinet)
A004836	Parts List and Drawing Control Panel Assembly	(Upright Cabinet)
A005612	Parts List and Drawing Control Panel Assembly	(Cocktail Table Cabinet)
A004856	Assembly Decal Location Diagram	(Upright Cabinet)
A005623	Assembly Decal Location Diagram	(Cocktail Table Cabinet)
A004838	Parts List and Drawing Electronics Tray Assembly	(for both)
A004847	Schematic Harness	(for both)
A004533	Schematic, Parts List and Drawing Printed Circuit Board	(for both)
(none)	Schematic Motorola XM501 Monitor	(for both)

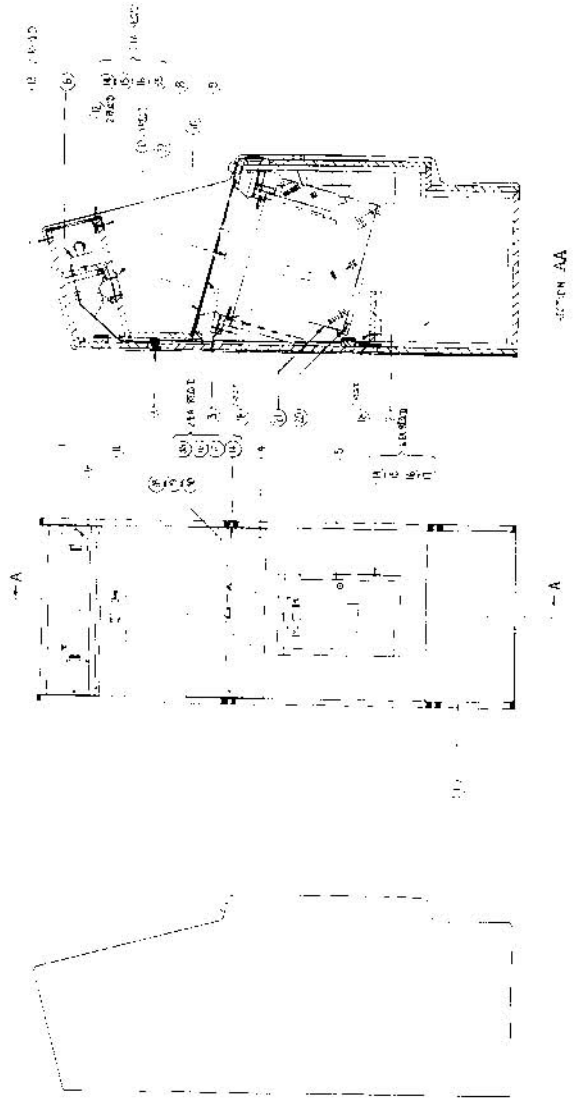

 ATARI CORPORATION 10100 NE 10TH AVENUE REDLANDS, CALIF. 92875	BREAKOUT TOP ASSEMBLY	
	D	A004833

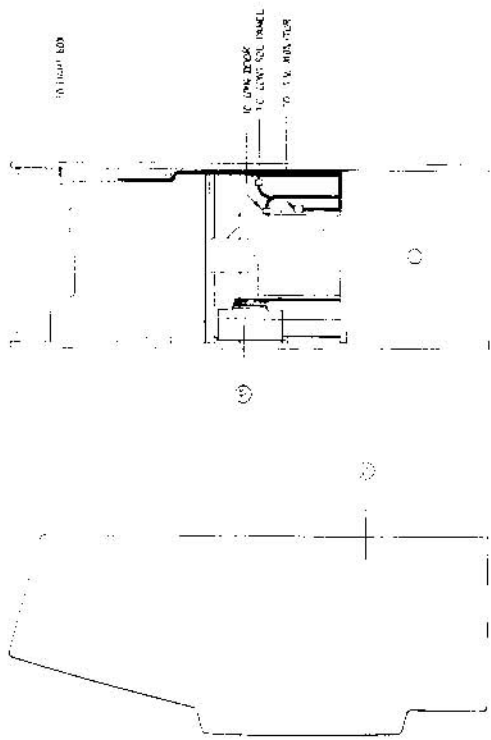

 ATARI <small>ATARI INCORPORATED 1430 S. HAYWARD AVE BERKELEY, CALIF. 94704</small>	
BREAKOUT SET A 5N	
D	A 004835
1	2

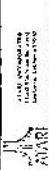
 AMARI THE TOP ASSEMBLY BREAKOUT	E 1005610
	1

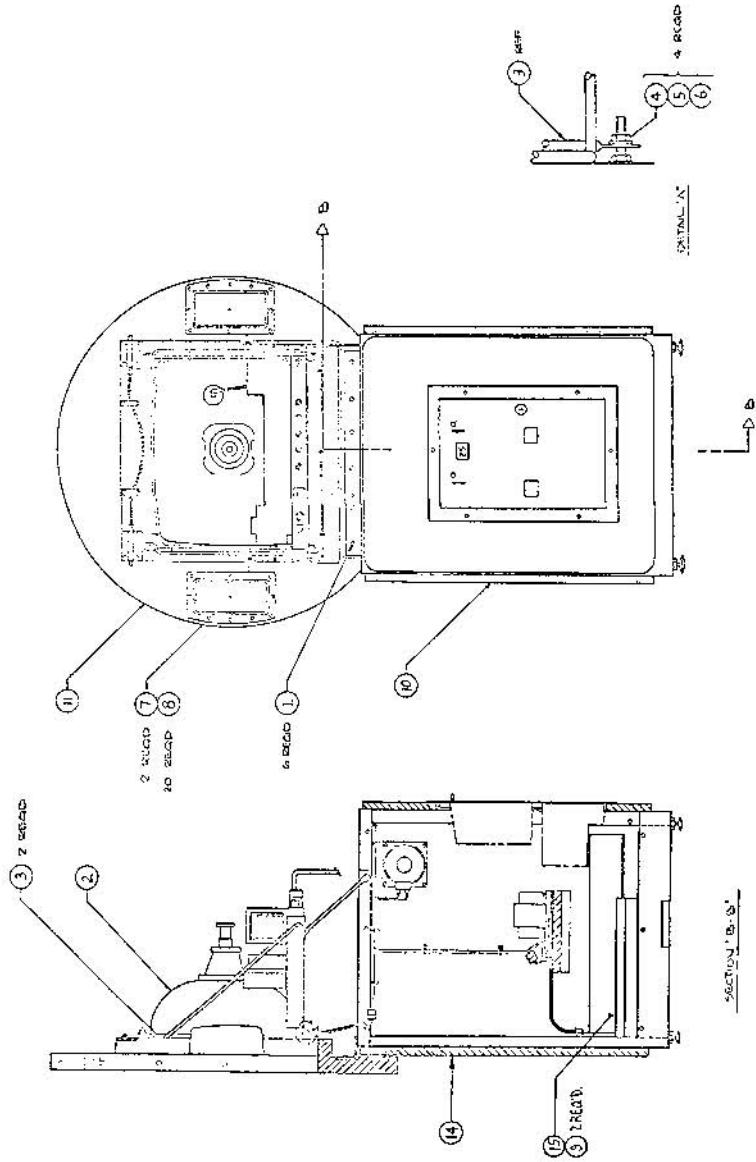

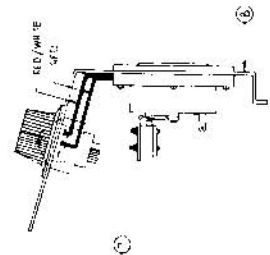
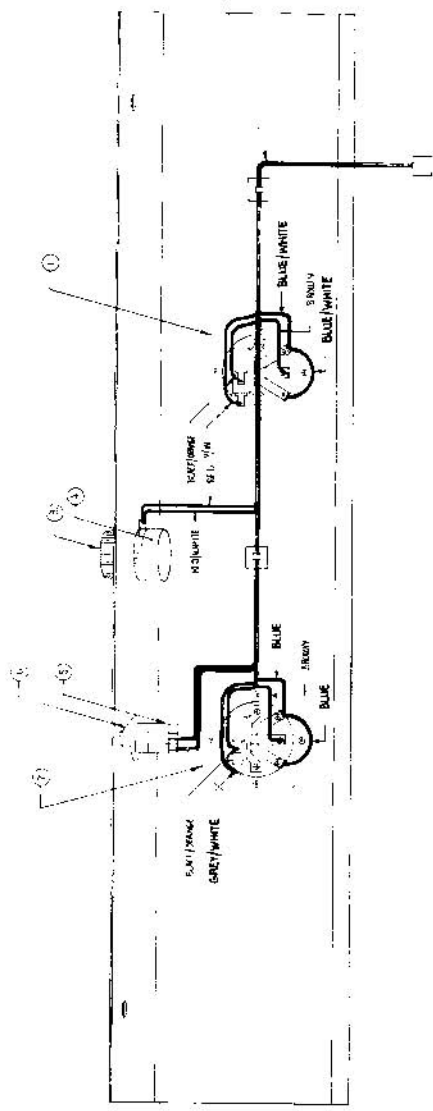

CONTROL PANEL ASSY	
PART NO.	A 00 46 3 6
REV.	C

BREAKOUT



ASSEMBLY TITLE / BREAKOUT ASSY
DECAL LOCATION DIAGRAM

P/L A004856

PARTS LIST SPECIFICATION

Page 1 of 1

Drawn			
Checked	4/20/76	Mech. Eng.	
Proj. Eng.	4/2/76	Elec. Eng.	
			REV. A

Rev.	Description	Date	Apprv.	Rev.	Description	Date	Apprv.
A	PROD REL	4/20/76					

Item	Part Number	Qty.	DESCRIPTION
1	005240-06	1	Decal, Color Strip - Red
2	005240-08	1	" " " - Amber
3	005240-05	1	" " " - Green
4	005240-07	1	" " " - Yellow
5	005240-11	1	" " " - Blue

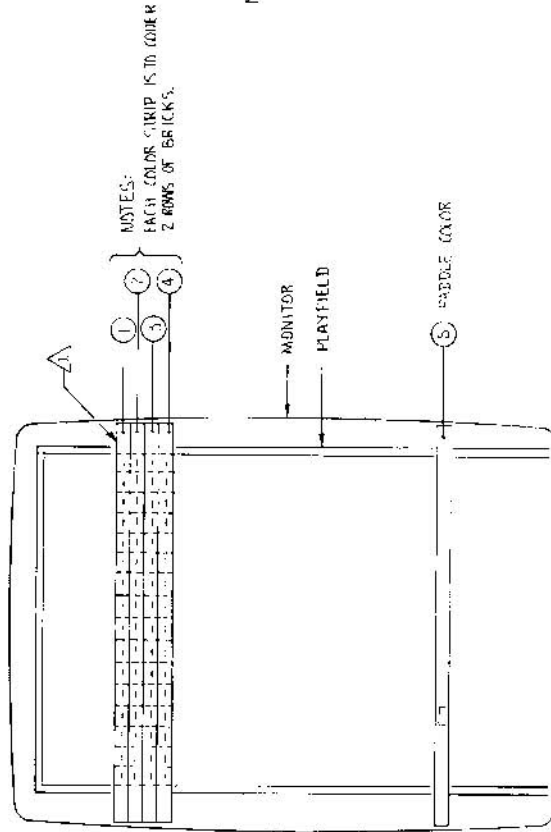

NOTES:

△ SINCE THE PLAYFIELD BRICKS ARE SO CLOSE TO ONE ANOTHER, PLACE THE FIRST STRIP CLOSE TO THEM TO BE FIRMING UP TO ONE OF THE OTHERS. ALSO WHEN APPLYING STRIPS REMEMBER THAT YOU GO A SLANT AND THAT THE FIRST STRIP TO BE APPLIED WHICH IS ITEM 4 WILL GO FIRST BE PLACED ON PLAYOUT THE BOTTOM 6 YOU DO BE AS A LITTLE BIT THAT YOU DO NOT SEE GATE STAYS WHEN YOU PLAY THE GAME.

 ATARI INCORPORATED 1400 W. SHARPE BLVD. LOS ANGELES, CALIFORNIA 90026	
ASSY. DECA: 11410N 71865 AM	
REV	DATE
C	1004856
BY	A

C.T. BREAKOUT



ASSEMBLY TITLE / ASSEMBLY, DECAL & LOCATION DIAGRAM P/L A005623

PARTS LIST SPECIFICATION Page 1 of 1

Drawn	
Checked	Mech. Eng.
Proj. Eng.	Elec. Eng.
	REV. A

Rev.	Description	Date	Apprv.	Rev.	Description	Date	Apprv.
A	PROD REC	5/14/76					

Item	Part Number	Qty.	DESCRIPTION
1	005240-06	2	Decal, Color Strip - Red
2	005240-08	2	" " " - Amber
3	005240-05	2	" " " - Green
4	005240-07	2	" " " - Yellow
5	002426	1	T.V. Monitor Modification Detail

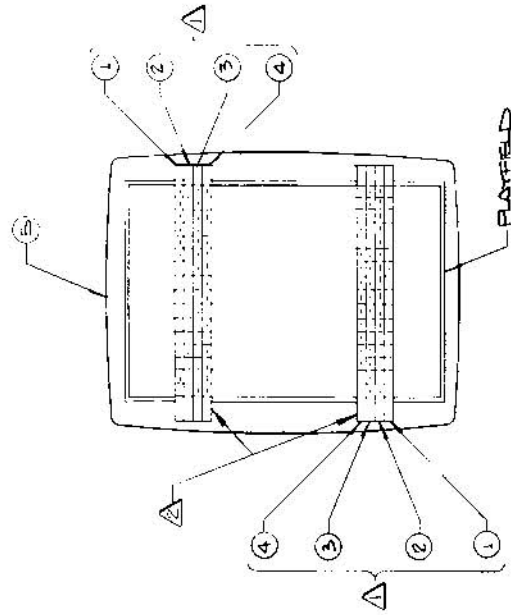

CURRENT VERSION -01

- △ EACH COLOR STRIP WILL COVER TWO ROWS OF BRICKS.
- △ THE PLAYFIELD BRICKS ARE SO CLOSE TO ONE ANOTHER THAT THE FIRST STRIP MUST BE PLACED CORRECTLY; THEY PLUCK REMAINING STRIPS OUT OF THE OTHER ALSO.
- △ WHEN APPLYING STRIPS REMEMBER THAT THE T.V. IS LYING FLAT AND

THE FIRST STRIP TO BE APPLIED (ITEM 4 (YELLOW)) SHOULD BE PLACED OVERLAPPING THE BOTTOM ROW OF BRICKS A LITTLE SO YOU DO NOT SEE WHITE BRICKS WHEN YOU PLAY THE GAME.

 ATARI INCORPORATED 1600 BAYVIEW BLVD BERKELEY, CALIFORNIA 94705	
TITLE ASSEMBLY DECAL LOCATION DIAGRAM	
PART NUMBER C 4005623	REV A
SHEET 1 OF 1	

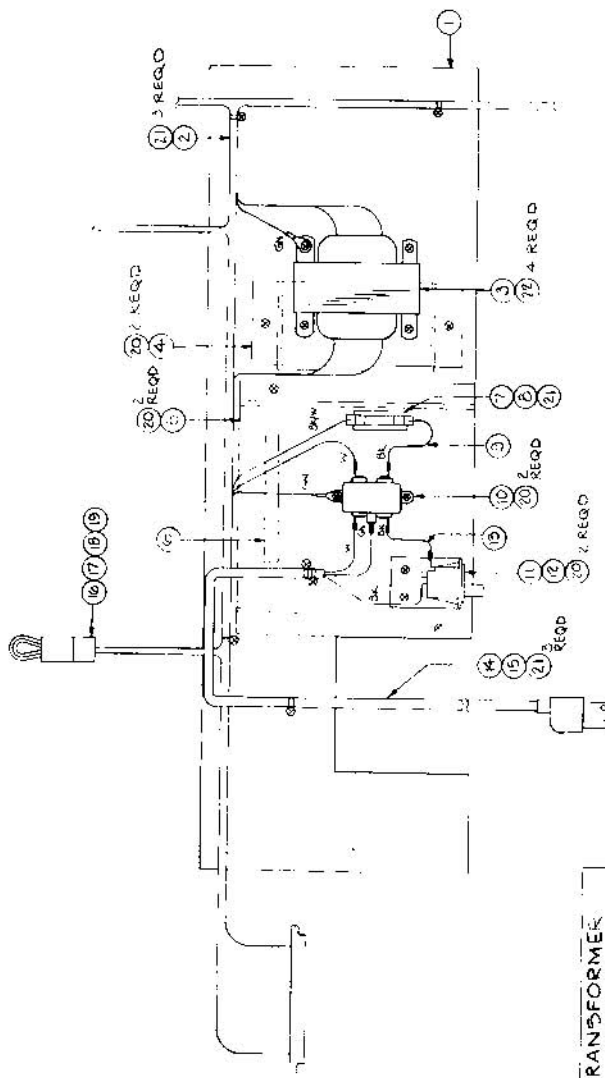

TRANSFORMER WIRING		
PIN NO	COLOR	SOURCE
1	OR	MAIN HARNESS
2	BU	
3	GN	
4	GN	
5	W	
6	GN/W	
7	W	
8	W	
9	W	
10	W	
11	W	
12	GN	
13	GN	
14	GN	
15	GN	

ATARI INCORPORATED
 1400 Wilshire Boulevard
 Los Angeles, California 90017

TITLE BREAKOUT
ELECTRONICS TRAY ASSY

PART NO. **C** DRAWING NO. **ACC4838** REV. **A**

EXC. HALF DESIGNED BY CHECKED BY

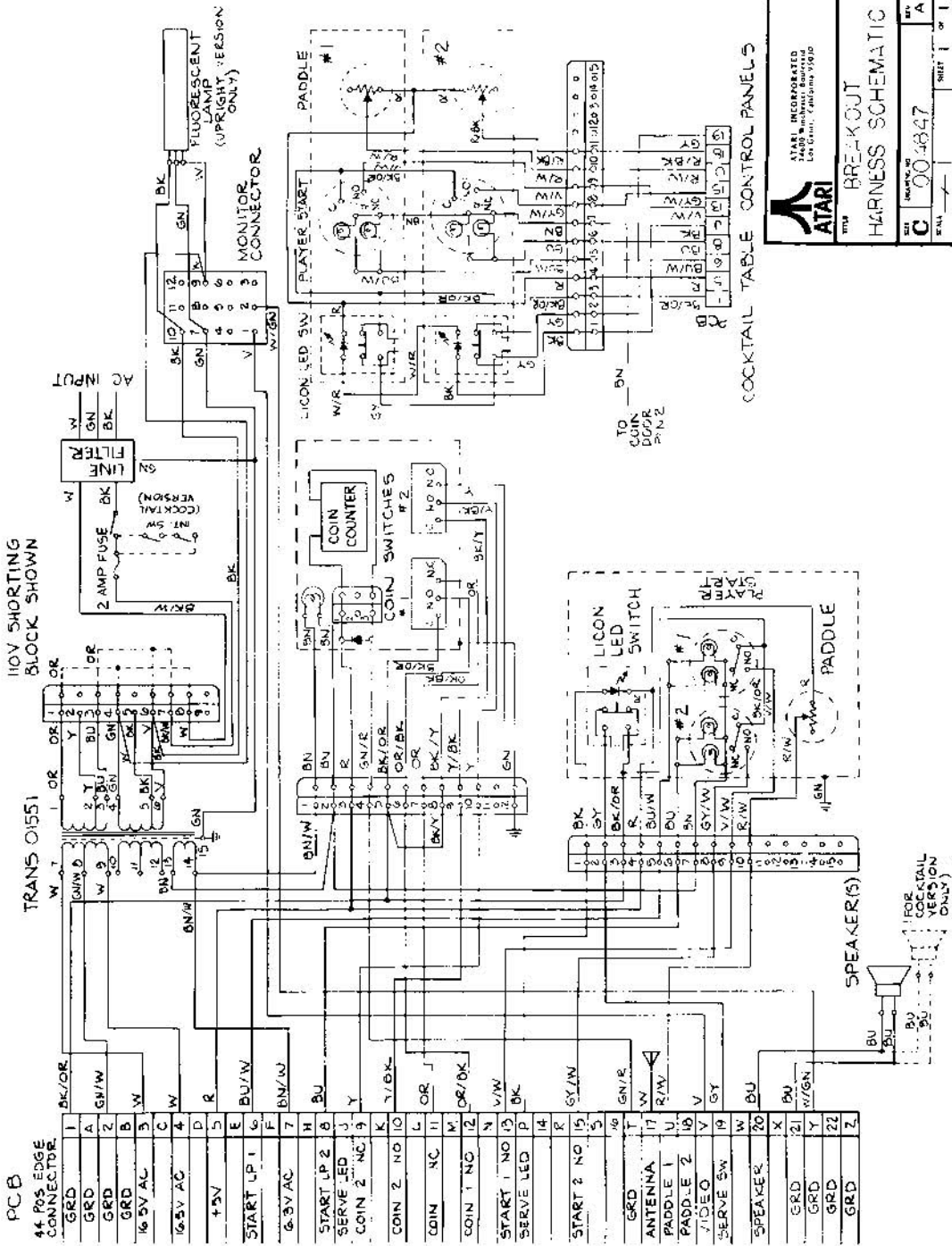

ATARI INCORPORATED
2400 Webster Street
Los Altos, California 95024

ATARI

BREAKOUT HARNESS SCHEMATIC

REV: **C** PART NO: **004847** SHEET **1** OF **1**

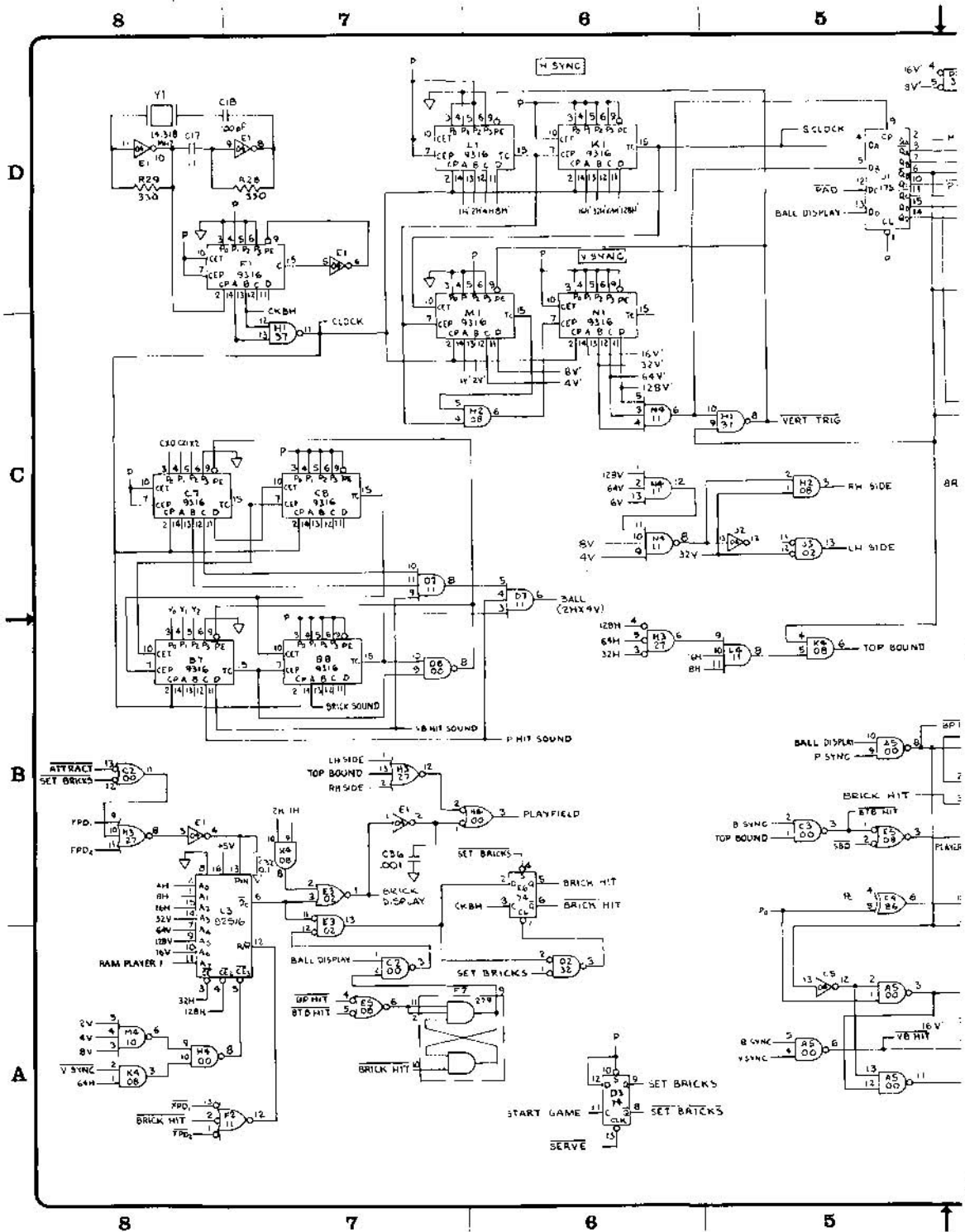

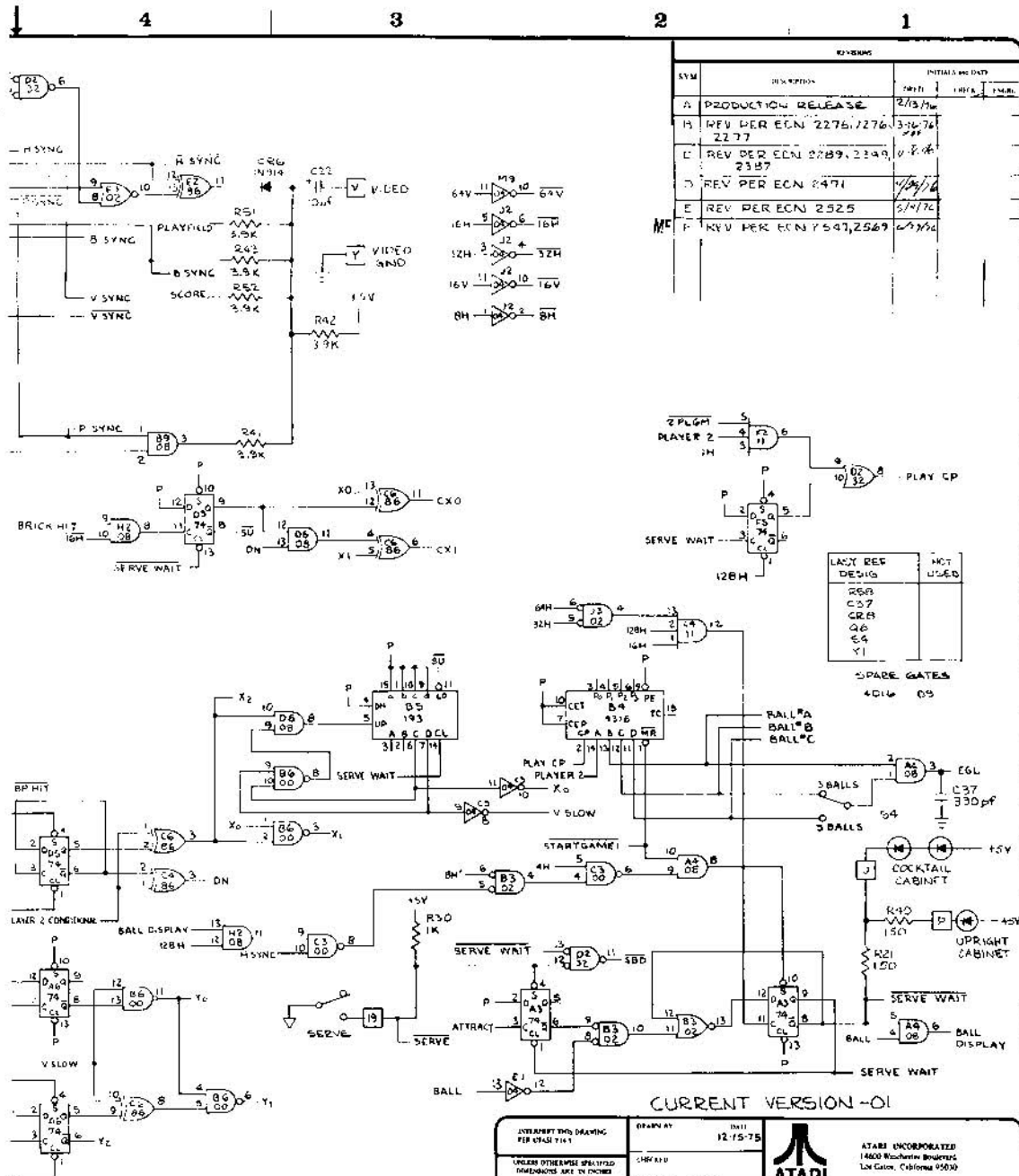

NOTES TO ALL PERSONS EXAMINING THIS DRAWING:
 1. CONVENTIONS: Reproduction of this drawing without the
 written permission of Atari, Inc. is prohibited.
 2. This drawing is not to be used for the design of any
 product without the written permission of Atari, Inc.
 3. This drawing is not to be used for the design of any
 product without the written permission of Atari, Inc.
 4. This drawing is not to be used for the design of any
 product without the written permission of Atari, Inc.

INTEREST THIS DRAWING PER ECN 714	DRAWN BY DATE 12/15/75	 ATARI ATARI INCORPORATED 1460 Woodside Boulevard Los Gatos, California 95030
DESIGN OTHERS DIMENSIONS ARE IN INCHES TOLERANCES ON	CHECKED BY DESIGN ENGINEER	
REVISIONS: 1-12/15/75 2-1/17/76 3-1/17/76	PROJECT ENGINEER DATE OF REV. CONTROL 1/17/76	
MATERIAL	DATE OF REV. CONTROL	TITLE SCHEMATIC DIAGRAM BREAKOUT
0004532 NEXT AWAY OPERATION	0004532 NEXT AWAY OPERATION	REV. D DRAWING NO. 004533 SHEET 1 OF 4

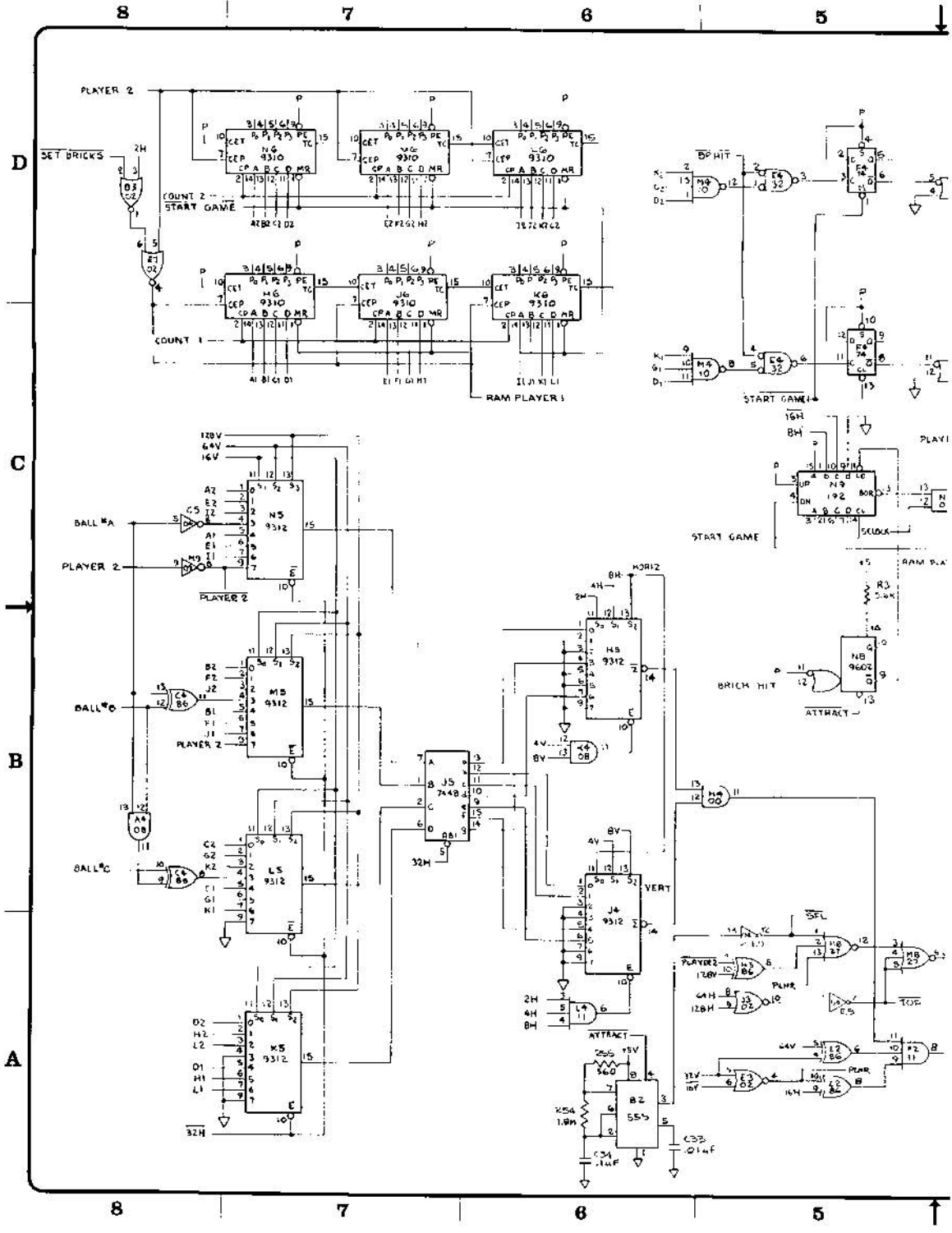

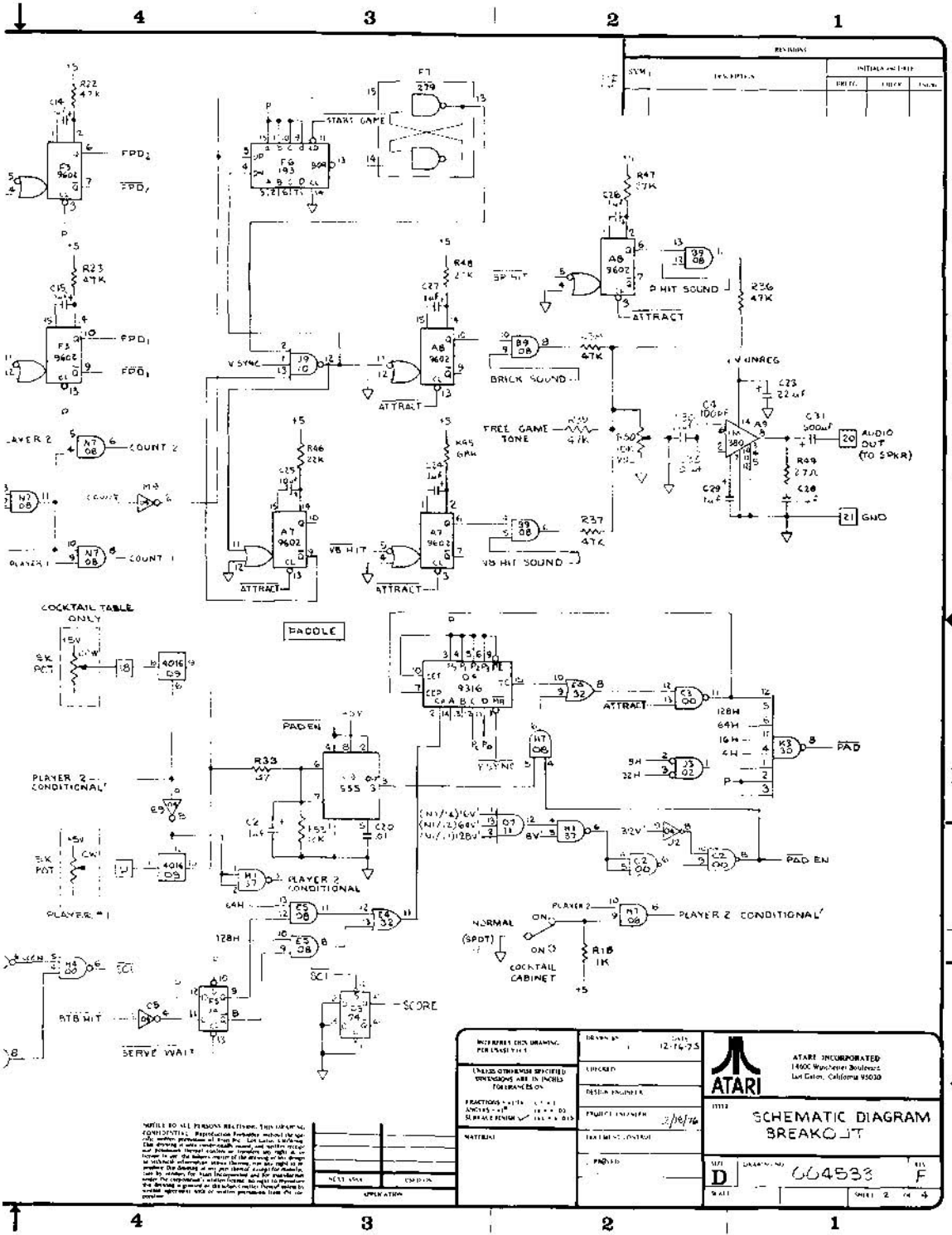

WRITE TO ALL PERSONS RECEIVING THIS DRAWING: CONFIDENTIAL. Reproduction forbidden without the written permission of Atari, Inc. Atari, Inc. is not responsible for any damage or loss resulting from the use of this drawing. The drawing of any component shown herein is not intended to represent the actual physical dimensions of the component. The drawing of any component shown herein is not intended to represent the actual physical dimensions of the component. The drawing of any component shown herein is not intended to represent the actual physical dimensions of the component. The drawing of any component shown herein is not intended to represent the actual physical dimensions of the component.

INCREASE THIS DRAWING PER LINE ITEM 1 THESE OTHERS SPECIFIED VENDORS ARE IN FULLY COMPLIANCE ON: PARTS: 117, 118, 119, 120, 121, 122, 123, 124, 125, 126, 127, 128, 129, 130, 131, 132, 133, 134, 135, 136, 137, 138, 139, 140, 141, 142, 143, 144, 145, 146, 147, 148, 149, 150, 151, 152, 153, 154, 155, 156, 157, 158, 159, 160, 161, 162, 163, 164, 165, 166, 167, 168, 169, 170, 171, 172, 173, 174, 175, 176, 177, 178, 179, 180, 181, 182, 183, 184, 185, 186, 187, 188, 189, 190, 191, 192, 193, 194, 195, 196, 197, 198, 199, 200, 201, 202, 203, 204, 205, 206, 207, 208, 209, 210, 211, 212, 213, 214, 215, 216, 217, 218, 219, 220, 221, 222, 223, 224, 225, 226, 227, 228, 229, 230, 231, 232, 233, 234, 235, 236, 237, 238, 239, 240, 241, 242, 243, 244, 245, 246, 247, 248, 249, 250, 251, 252, 253, 254, 255, 256, 257, 258, 259, 260, 261, 262, 263, 264, 265, 266, 267, 268, 269, 270, 271, 272, 273, 274, 275, 276, 277, 278, 279, 280, 281, 282, 283, 284, 285, 286, 287, 288, 289, 290, 291, 292, 293, 294, 295, 296, 297, 298, 299, 300, 301, 302, 303, 304, 305, 306, 307, 308, 309, 310, 311, 312, 313, 314, 315, 316, 317, 318, 319, 320, 321, 322, 323, 324, 325, 326, 327, 328, 329, 330, 331, 332, 333, 334, 335, 336, 337, 338, 339, 340, 341, 342, 343, 344, 345, 346, 347, 348, 349, 350, 351, 352, 353, 354, 355, 356, 357, 358, 359, 360, 361, 362, 363, 364, 365, 366, 367, 368, 369, 370, 371, 372, 373, 374, 375, 376, 377, 378, 379, 380, 381, 382, 383, 384, 385, 386, 387, 388, 389, 390, 391, 392, 393, 394, 395, 396, 397, 398, 399, 400, 401, 402, 403, 404, 405, 406, 407, 408, 409, 410, 411, 412, 413, 414, 415, 416, 417, 418, 419, 420, 421, 422, 423, 424, 425, 426, 427, 428, 429, 430, 431, 432, 433, 434, 435, 436, 437, 438, 439, 440, 441, 442, 443, 444, 445, 446, 447, 448, 449, 450, 451, 452, 453, 454, 455, 456, 457, 458, 459, 460, 461, 462, 463, 464, 465, 466, 467, 468, 469, 470, 471, 472, 473, 474, 475, 476, 477, 478, 479, 480, 481, 482, 483, 484, 485, 486, 487, 488, 489, 490, 491, 492, 493, 494, 495, 496, 497, 498, 499, 500, 501, 502, 503, 504, 505, 506, 507, 508, 509, 510, 511, 512, 513, 514, 515, 516, 517, 518, 519, 520, 521, 522, 523, 524, 525, 526, 527, 528, 529, 530, 531, 532, 533, 534, 535, 536, 537, 538, 539, 540, 541, 542, 543, 544, 545, 546, 547, 548, 549, 550, 551, 552, 553, 554, 555, 556, 557, 558, 559, 560, 561, 562, 563, 564, 565, 566, 567, 568, 569, 570, 571, 572, 573, 574, 575, 576, 577, 578, 579, 580, 581, 582, 583, 584, 585, 586, 587, 588, 589, 590, 591, 592, 593, 594, 595, 596, 597, 598, 599, 600, 601, 602, 603, 604, 605, 606, 607, 608, 609, 610, 611, 612, 613, 614, 615, 616, 617, 618, 619, 620, 621, 622, 623, 624, 625, 626, 627, 628, 629, 630, 631, 632, 633, 634, 635, 636, 637, 638, 639, 640, 641, 642, 643, 644, 645, 646, 647, 648, 649, 650, 651, 652, 653, 654, 655, 656, 657, 658, 659, 660, 661, 662, 663, 664, 665, 666, 667, 668, 669, 670, 671, 672, 673, 674, 675, 676, 677, 678, 679, 680, 681, 682, 683, 684, 685, 686, 687, 688, 689, 690, 691, 692, 693, 694, 695, 696, 697, 698, 699, 700, 701, 702, 703, 704, 705, 706, 707, 708, 709, 710, 711, 712, 713, 714, 715, 716, 717, 718, 719, 720, 721, 722, 723, 724, 725, 726, 727, 728, 729, 730, 731, 732, 733, 734, 735, 736, 737, 738, 739, 740, 741, 742, 743, 744, 745, 746, 747, 748, 749, 750, 751, 752, 753, 754, 755, 756, 757, 758, 759, 760, 761, 762, 763, 764, 765, 766, 767, 768, 769, 770, 771, 772, 773, 774, 775, 776, 777, 778, 779, 780, 781, 782, 783, 784, 785, 786, 787, 788, 789, 790, 791, 792, 793, 794, 795, 796, 797, 798, 799, 800, 801, 802, 803, 804, 805, 806, 807, 808, 809, 810, 811, 812, 813, 814, 815, 816, 817, 818, 819, 820, 821, 822, 823, 824, 825, 826, 827, 828, 829, 830, 831, 832, 833, 834, 835, 836, 837, 838, 839, 840, 841, 842, 843, 844, 845, 846, 847, 848, 849, 850, 851, 852, 853, 854, 855, 856, 857, 858, 859, 860, 861, 862, 863, 864, 865, 866, 867, 868, 869, 870, 871, 872, 873, 874, 875, 876, 877, 878, 879, 880, 881, 882, 883, 884, 885, 886, 887, 888, 889, 890, 891, 892, 893, 894, 895, 896, 897, 898, 899, 900, 901, 902, 903, 904, 905, 906, 907, 908, 909, 910, 911, 912, 913, 914, 915, 916, 917, 918, 919, 920, 921, 922, 923, 924, 925, 926, 927, 928, 929, 930, 931, 932, 933, 934, 935, 936, 937, 938, 939, 940, 941, 942, 943, 944, 945, 946, 947, 948, 949, 950, 951, 952, 953, 954, 955, 956, 957, 958, 959, 960, 961, 962, 963, 964, 965, 966, 967, 968, 969, 970, 971, 972, 973, 974, 975, 976, 977, 978, 979, 980, 981, 982, 983, 984, 985, 986, 987, 988, 989, 990, 991, 992, 993, 994, 995, 996, 997, 998, 999, 1000.	DESIGNER: DESIGN ENGINEER: DATE: 12-16-75 PARTS LIST: PARTS ENGINEER: 2/10/76 DRAWING NO.: 664533 TITLE: SCHEMATIC DIAGRAM BREAKOUT
--	---

D
 C
 B
 A

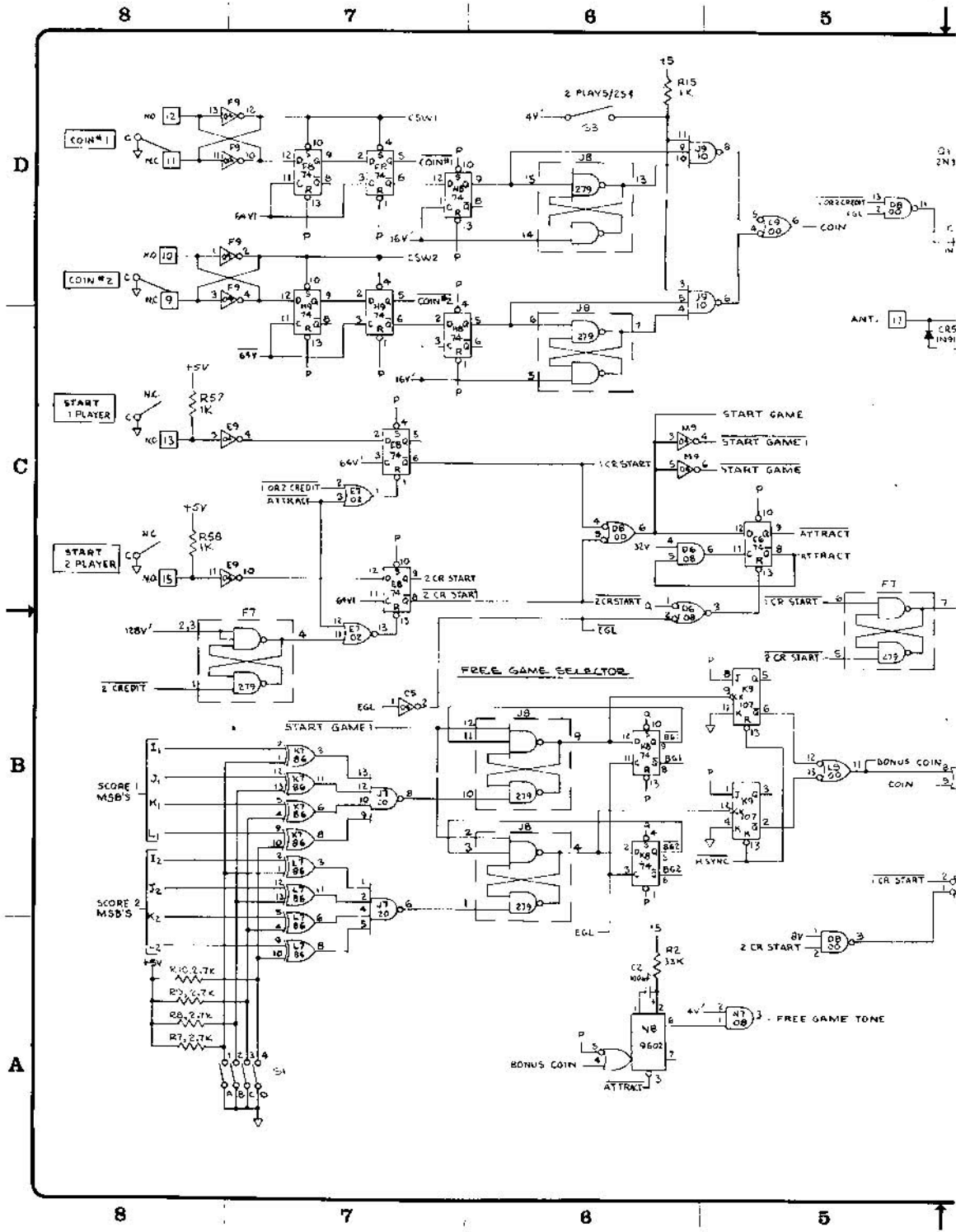

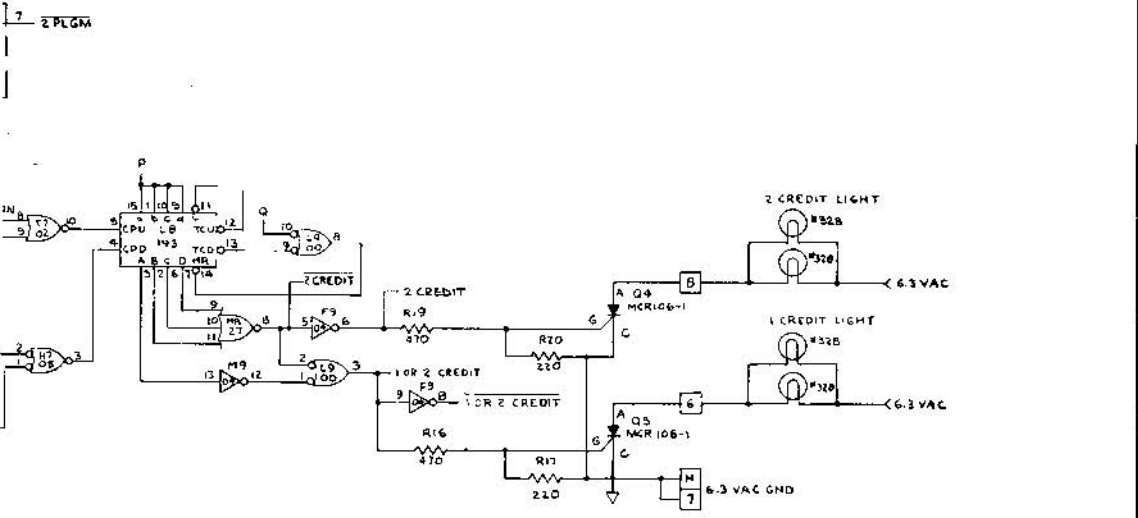
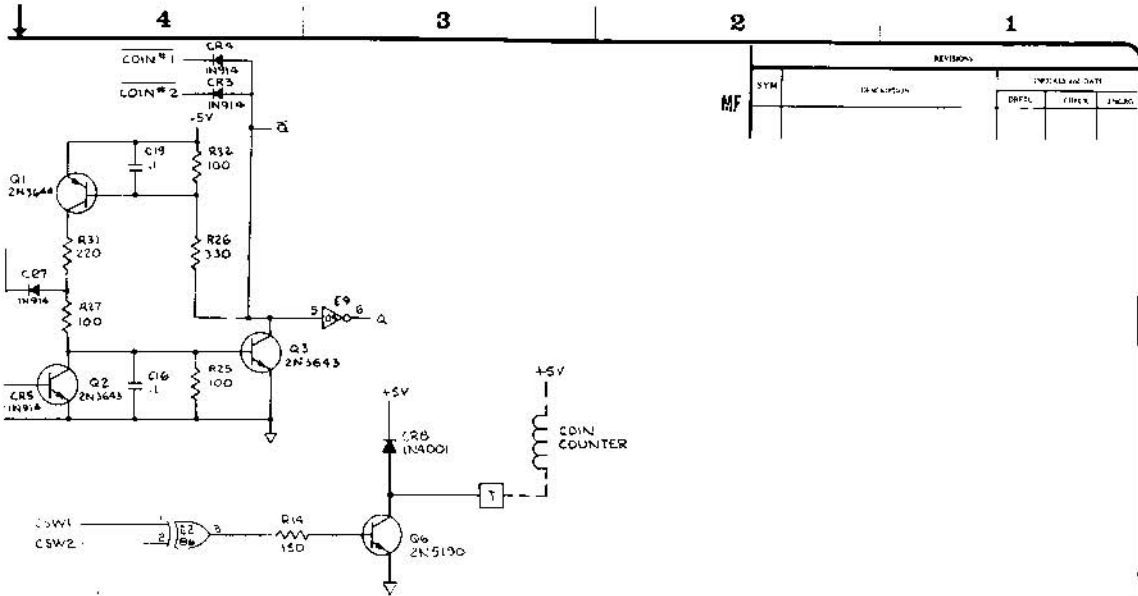

NOTE TO ALL PERSONS RECEIVING THIS DRAWING: CONSULT THE ATARI CORPORATION FOR THE LATEST REVISIONS OF THIS DRAWING. THE ATARI CORPORATION IS NOT RESPONSIBLE FOR ANY DAMAGE TO PROPERTY OR PERSONS RESULTING FROM THE USE OF THIS DRAWING. THE ATARI CORPORATION IS NOT RESPONSIBLE FOR ANY DAMAGE TO PROPERTY OR PERSONS RESULTING FROM THE USE OF THIS DRAWING.

<p>UNLESS OTHERWISE SPECIFIED DIMENSIONS ARE IN INCHES TOLERANCES ON:</p> <p>FRACTIONS ±.016</p> <p>DECIMALS ±.010</p> <p>SURFACE FINISH: .0005</p>	<p>DATE: 12-16-75</p> <p>DESIGNED BY: []</p> <p>DESIGN ENGINEER: []</p> <p>PROJECT ENGINEER: 2/14/76</p> <p>DATE: 12-16-75</p>	<p>ATARI INCORPORATED</p> <p>14625 Finch Avenue</p> <p>Los Gatos, California 95030</p>
<p>REVISIONS</p> <p>SYMBOL: MF</p> <p>DESCRIPTION: []</p> <p>DATE: []</p> <p>BY: []</p> <p>CHECKED BY: []</p>	<p>TITLE: SCHEMATIC DIAGRAM BREAKOUT</p> <p>DRAWING NO: 004533</p> <p>REV: F</p> <p>SHEET 3 OF 4</p>	<p>APPROVED BY: []</p> <p>DATE: []</p>

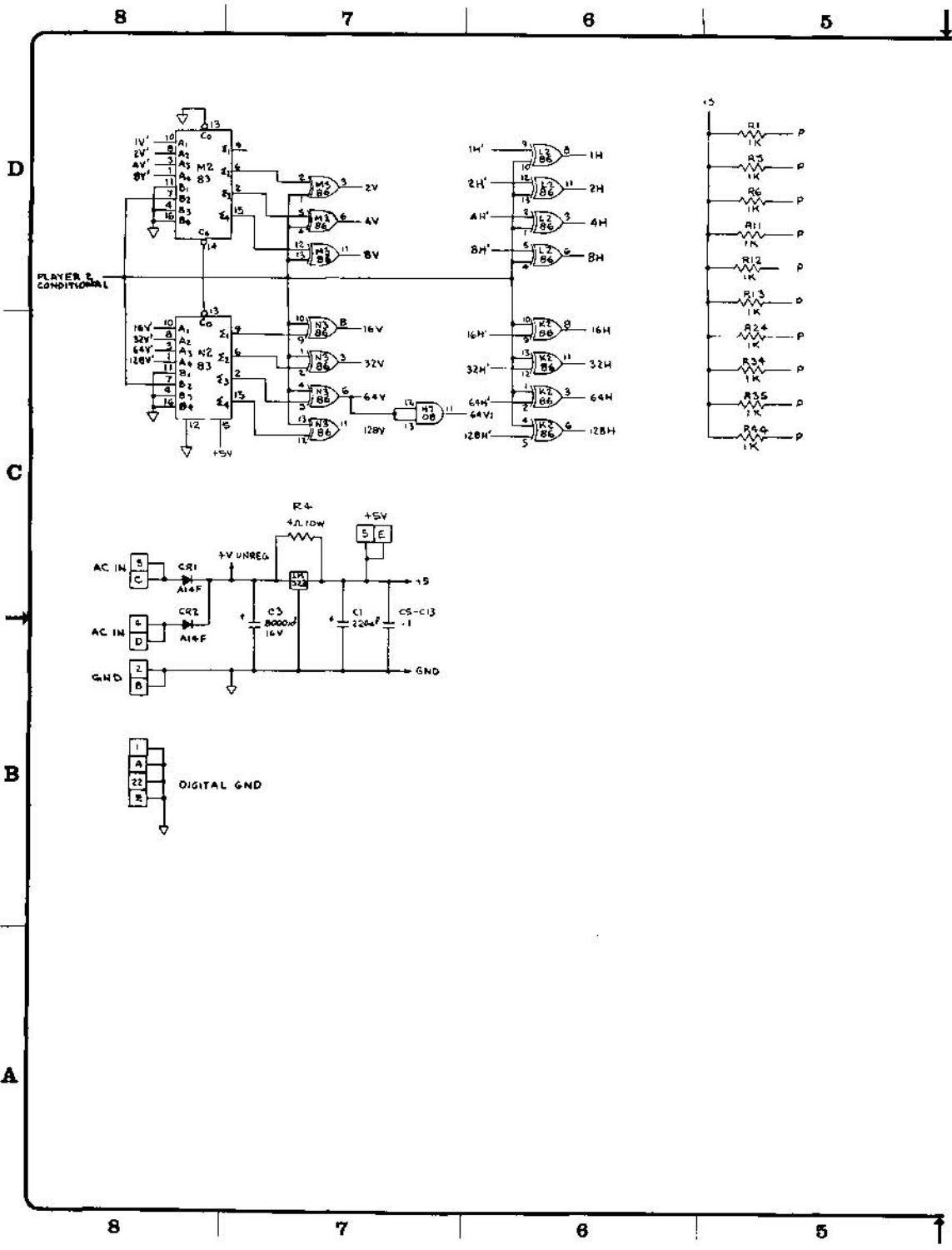

4 3 2 1

REV	SYM	DESCRIPTION	DATE		
			DATE	CHKD	DATE
MF					

D

C

B

A

DATE
JOB
BY

NOTES TO ALL PERSONS RECEIVING THIS DRAWING:
 CONFIDENTIAL. Reproduction forbidden without the express written permission of Atari, Inc. This drawing is not to be used for any other purpose than that for which it was prepared. It is the property of Atari, Inc. and is loaned to you for your information only. It is not to be distributed outside your organization. If you have any questions regarding this drawing, please contact the person named in the title block of this drawing. If you have any suggestions for improvement, please contact the person named in the title block of this drawing.

APPLICATOR	
DATE	

INTERPRET THIS DRAWING PER USAS V14.5 UNLESS OTHERWISE SPECIFIED DIMENSIONS ARE IN INCHES TOLERANCES ON: FINISHES = 1/16" ± .015" HOLEES = .015" ± .005" SURFACE FINISH = 320 ± .010"	DRAWN BY: [] DATE: 12-16-75 CHECKED: [] DESIGN ENGINEER: PROJECT ENGINEER: 2/1/76 DOCUMENT CONTROL: APPROVED: []	 ATARI INCORPORATED 1460 Woodhurst Boulevard Los Gatos, California 95030 TITLE: SCHEMATIC DIAGRAM BREAKOUT SIZE: D DRAWING NO: 004583 REV: F SHEET 4 OF 4
---	---	--

4 3 2 1

BREAKOUT



ASSEMBLY TITLE / ASSY, BREAKOUT P.C. BOARD P/L A004533-01

PARTS LIST SPECIFICATION Page 1 of 3

Drawn		Mech. Eng.	
Checked		Elec. Eng.	
Proj. Eng.			REV. F
MF			

Rev.	Description	Date	Apprv.	Rev.	Description	Date	Apprv.
A	PROD. RELEASE	2/18/76		F	REV PER ECN 2547,2569	4/29/76	
B	REV PER ECN 2275, 2276, 2277	3-17-76					
C	REV PER ECN 2289,2349, 2387	4-8-76					
D	REV PER ECN 2471	4-29-76					
E	REV PER ECN 2525	5/3/76					

Item	Part Number	Qty.	DESCRIPTION
1	004532-01	1	P.C. Board
2	10-5101	3	Resistor, Carbon, 1/4w, 5%, 100 OHM R25,27,32
3	10-5102	15	" " " " 1K OHM R1,5,6,11,12,13, 18,57 R24,30,34,35,44, 15,58
4	10-5151	3	" " " " 150 OHM R14,21,40
5	10-5185	1	" " " " 1.8M OHM R54
6	10-52p7	1	" " " " 2.7 OHM R49
7	10-5221	3	" " " " 220 OHM R17,20,31
8	10-5470	1	" " " " 47 OHM R33
9	10-5223	1	" " " " 22K OHM R46
10	10-5273	2	" " " " 27K OHM R47,48
11	10-5331	3	" " " " 330 OHM R26,28,29
12	10-5392	5	" " " " 3.9K OHM R41-43,51,52
13	10-5333	1	" " " " 33K OHM R2
14	10-5471	2	" " " " 470 OHM R16,R19
15	10-5473	6	" " " " 47K OHM R22,23,36-39
16	10-5561	1	" " " " 560 OHM R55
17	10-5562	1	" " " " 5.6K OHM R3
18	10-5683	1	" " " " 68K OHM R45
19	10-5272	4	Resistor, Carbon, 1/4w, 5% 2.7K OHM R7-10
20	19-808W4P0	1	Resistor, Wirewound, 10w 4 OHM, 20% R4
21	10-5123	1	RES, CARBON, 1/4w, 5%, 12K OHM R53
22	19-315103	1	Trimpot, 10K R50
23	24-250105	7	Capacitor, Elect. 1uf, 25V C14,15,24,26,27,29,21
24	24-250106	2	" " 10uf, 25V C22,25
25	24-250107	1	" " 100uf, 25V C2

ASSEMBLY TITLE		P.C. BOARD		P/L ADD4533-01 REV. F.	
PARTS LIST SPECIFICATION		DESCRIPTION		Page 2 of 3	
Item	Part Number	Qty.	DESCRIPTION		
26					
27	24-250226	1	" " 22uf, 25V	C23	
28	24-250257	1	" " 220uf, 25V	C1	
29	24-250507	1	" " 500uf, 25V	C31	
30	24-160808	1	" " 8000uf, 16V	C3	
31	27-250103	3	Capacitor, Ceramic, .01uf, 25V	C20,33,35	
32	27-250104	16	" " .1uf, 25V	C5-13,16,17,19,	
				C28,30,32,34	
33	28-101101	2	Capacitor, Dipped Mica, 100pf, 100V, C18, 4	C36	
34	27-250102	1	Capacitor, Ceramic, .001uf, 25V	C36	
35	31-1N4001	1	Diode, 1N4001	CR8	
36	31-A14F	2	Diode, A14F	CR1,2	
37	31-1N914	5	Diode, 1N914	CR3-7	
38	33-2N3644	1	Transistor, 2N3644	Q1	
39	34-2N3643	2	Transistor, 2N3643	Q2,3	
40	35-MCR106-1	2	Transistor, MCR106-1	Q4,5	
41	34-2N5190	1	Transistor, 2N5190	Q6	
42	37-7400	7	Integrated Circuit, 7400		
43	37-7402	4	" " 7402		
44	37-7404	6	" " 7404		
45	37-7408	8	" " 7408		
46	37-7410	2	" " 7410		
47	37-7411	4	" " 7411		
48	37-7420	1	" " 7420		
49	37-7427	2	" " 7427		
50	37-7430	1	" " 7430		
51	37-7432	2	" " 7432		
52	37-7437	1	" " 7437		
53	37-7448	1	" " 7448		
54	37-7474	12	" " 7474		
55	37-7483	2	" " 7483		
56	37-7486	9	" " 7486		
57	37-74107	1	" " 74107		
58	37-74175	1	" " 74175		
59	37-74182	1	" " 74182		
60	37-74193	3	" " 74193		
61	90-7008	1	" " 82S16 RAM		

ASSEMBLY TITLE		P.C. BOARD		P/L ADD4533-01 REV. F.	
PARTS LIST SPECIFICATION		DESCRIPTION		Page 3 of 3	
Item	Part Number	Qty.	DESCRIPTION		
62	37-74279	2	Integrated Circuit, 74279		
63	37-4016	1	" " 4016		
64	37-555	2	" " 555		
65	37-9310	6	" " 9310		
66	37-9312	6	" " 9312		
67	37-9316	11	" " 9316		
68	37-9602	4	" " 9602		
69	37-LM380	1	" " LM380		
70	37-LM323	1	Regulator LM323		
71					
72	66-0245PST	1	Switch S1		
73	69-001	3	Slide Switch, DPDT S2,3,4		
74	78-06001	1	Heatsink		
75	72-1608C	2	Screw, Mach, Pan Hd, Phill, #6-32x4 CRES		
76	75-016	2	Washer, Flat #6		
77	75-056	2	Washer, Lock, Int. Star #6		
78	75-916C	2	Mut. Machine, Hex, #6-32 CRES		
79	78-16005	1	Sil-Pad		
80	90-101	1	Crystal, 14.31818 MHZ	Y1	
81	27-101331	1	Capacitor, Ceramic, 330pf, 100V	C37	

NOTES: UNLESS OTHERWISE SPECIFIED

1. ALL DIODES ARE IN791A.
2. THIS APPLY TO BE USES WITH 004533 REV'D P.C. BD.

MODIFICATIONS TO ASSEMBLY PC. BD. REV. C

1. CHANGE CAPACITOR C21 FROM 2.2μF/25V TO 10μF/25V.
- RESISTOR R55 FROM 47K TO 12K.
- RESISTOR R53 FROM 100Ω TO 47Ω.
2. CUT AND LIFT PIN 2 OF U9.
3. JUMPER LIFTED PIN 2 OF U9 TO PIN 4 OF U9.

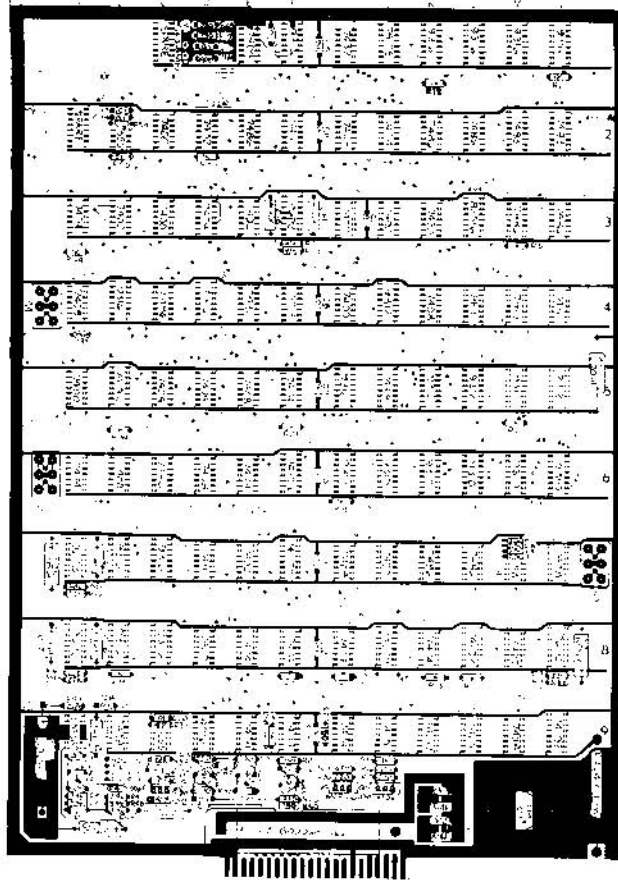

CURRENT VERSION -01

PREPARED BY: [blank] DATE: 4/2/76	ATARI INCORPORATED 1400 Philadelphia Boulevard Redwood City, California 94061
TITLE: ASSEMBLY, BREAKOUT PC. BD.	FILE: A
PART NUMBER: A004533	
REV: D	REV: F
2	1

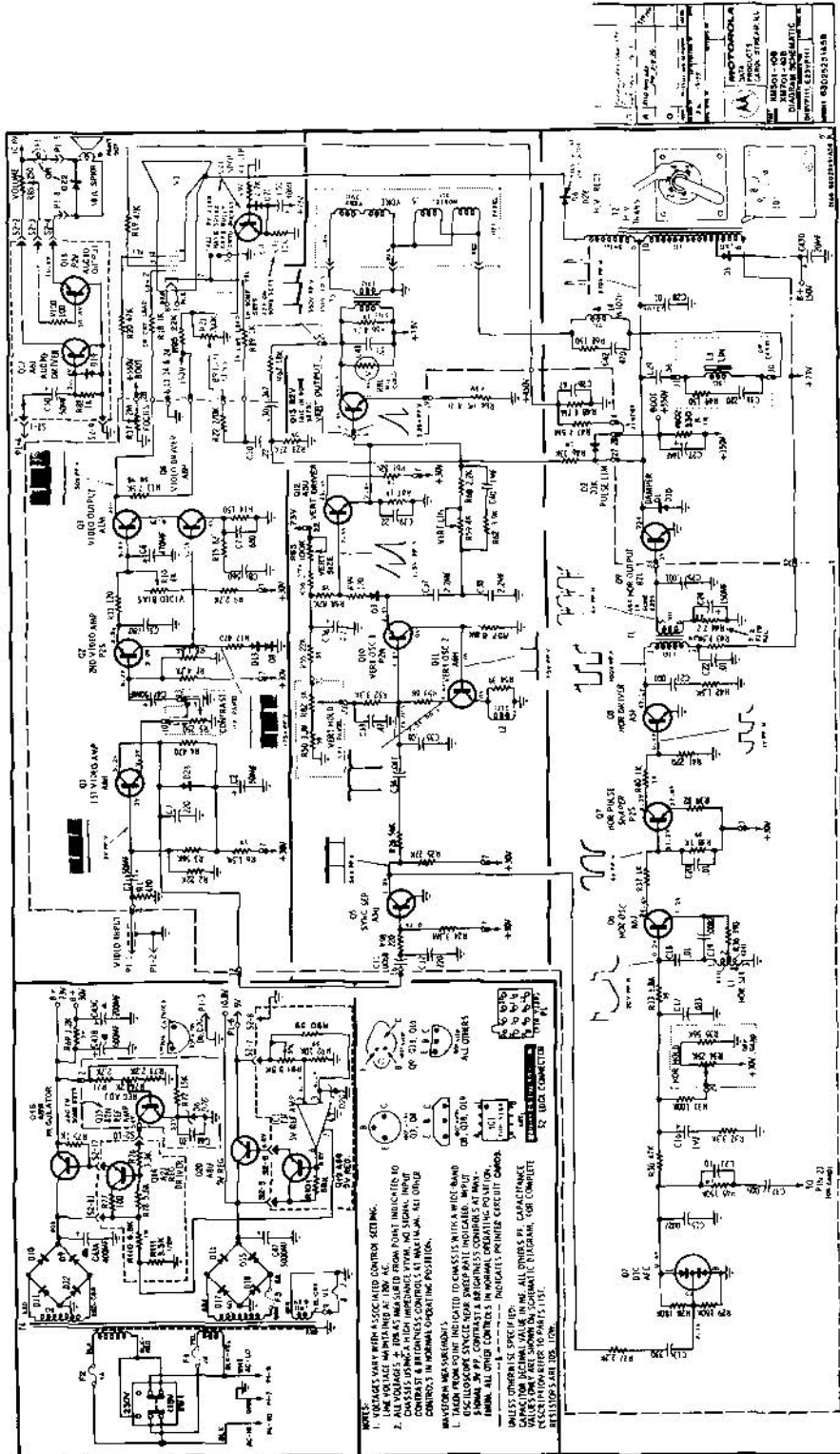

NOTES:

1. VOLTAGE VARY WITH ASSOCIATED CONTROL SETTING.
2. THE VOLTAGE INDICATED AT 100% FROM POINT INDICATES TO CHASSIS UNLESS A HIGH IMPEDANCE VTVM, AC SIGNAL INPUT CONTROLS & BRIGHTNESS CONTROL SET MAXIMUM. ALL OTHER CONTROLS IN POSITION.
3. ALL VACUUM POINT INDICATED TO CHASSIS UNLESS WITH A WIRE-BAND OSCILLOSCOPE SINCE NEAR WIRE-BAND INDICATED. INPUT SIGNAL IN THIS POSITION IS BEING USED FOR OPERATING POSITION.
4. UNLESS OTHERWISE SPECIFIED, ALL VALUES IN CAPACITANCE VALUES ARE IN MICROFARADS. IN OHMS, UNLESS OTHERWISE INDICATED TO POINTS LIST.

RESISTORS AND CAPACITORS:

- RESISTORS: ALL VALUES IN OHMS UNLESS OTHERWISE INDICATED.
- CAPACITORS: ALL VALUES IN MICROFARADS UNLESS OTHERWISE INDICATED.

MOTOR-ON MOTOR LABORATORIES, INC. 1000 WEST 10TH AVENUE DENVER, COLORADO 80202	DRAWING NO. 100-1000 REV. 10-1-58 SHEET 1 OF 1
---	--