

1st printing

TM-137

BASKETBALL



Operation,
Maintenance
and Service Manual

Complete with Illustrated Parts Catalog





BASKETBALL™

Operation, Maintenance and Service Manual

Complete with Illustrated Parts Catalog

ATARI, INC.
1265 BORREGAS AVENUE
P.O. BOX 427
SUNNYVALE, CALIFORNIA 94086
408/745-2000 • TELEX 35-7488

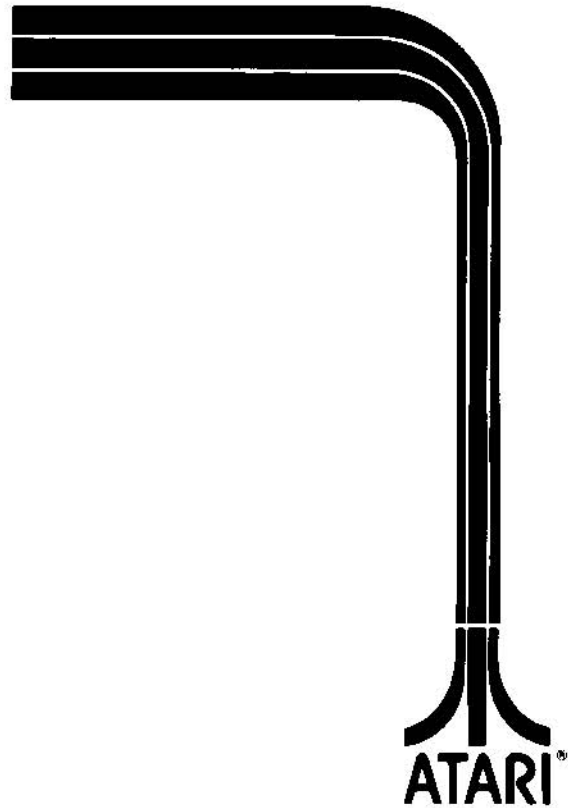

A Warner Communications Company 

table of contents

1 location setup

A. INTRODUCTION	1-1
B. GAME INSPECTION	1-2
C. INSTALLATION REQUIREMENTS	1-3
Low-Voltage Problems	1-3
High-Voltage Problems	1-3
D. INTERLOCK AND POWER ON/OFF SWITCH	1-4
E. SELF-TEST PROCEDURE	1-5
F. VOLUME ADJUSTMENT	1-5
G. OPERATOR OPTIONS	1-8

2 game play

A. INTRODUCTION	2-1
B. ATTRACT MODE	2-2
C. PLAY MODE	2-2
D. SELF-TEST MODE	2-2

3 maintenance and adjustments

A. INTRODUCTION	3-1
B. CLEANING	3-2
C. GAME FUSES	3-2
D. PLAYER CONTROL PANEL	3-3
1. LED Start/Shoot/Jump Switches	3-3
2. Trak Ball™ Assemblies	3-3
E. LOUDSPEAKERS	3-5
F. FLUORESCENT LAMP	3-5
G. TV MONITOR REMOVAL	3-5
H. GAME PCB	3-6

table of contents

4 details of electronic operation

A. GENERAL INFORMATION	4-1
B. POWER SUPPLY	4-5
C. MICROCOMPUTER CIRCUITRY	4-6
MPU, ROM, and RAM	4-6
Address Decoding	4-6
$\Phi 0$ Clock Driver	4-6
Watchdog Reset	4-11
D. SYNC GENERATOR	4-11
E. PLAYFIELD GENERATOR	4-11
F. MOTION OBJECT GENERATOR	4-16
G. VIDEO SUMMING CIRCUIT	4-18
H. TRAK BALL™ CONTROL AND SWITCH INPUT CIRCUITRY	4-19
I. AUDIO CIRCUITRY	4-19

5 illustrated parts catalog

list of tables

Table 1-1	Self-Test Procedure	1-6
Table 1-2	Faulty Circuits or Chips	1-7
Table 1-3	Operator Option Switch Settings	1-9
Table 4-1	Game PCB Memory Map	4-10

list of illustrations

Figure 1-1	Control Panel and Player Controls	1-2
Figure 1-2	Voltage Selection Plugs	1-3
Figure 1-3	Power On/Off and Interlock Switches	1-4
Figure 1-4	Volume Control and Self-Test Switch	1-5
Figure 1-5	Operator Option Switches	1-8
Figure 3-1	Game Fuses	3-2
Figure 3-2	Hinging the Control Panel Open	3-3
Figure 3-3	LED Start Switch Testing and Replacement	3-4
Figure 3-4	Trak Ball™ Assembly Removal	3-4
Figure 3-5	Removing the TV Monitor	3-5
Figure 3-6	Removing the Game PCB	3-6
Figure 4-1	Game Block Diagram	4-2
Figure 4-2	Game PCB Block Diagram	4-3
Figure 4-3	Game Wiring Diagram	4-4
Figure 4-4	Game PCB Power Distribution	4-6
Figure 4-5	MPU Circuit Schematic Diagram	4-7
Figure 4-6	ROM Memory Schematic Diagram	4-8
Figure 4-7	RAM Memory Schematic Diagram	4-9
Figure 4-8	Address Decoding Schematic Diagram	4-9
Figure 4-9	Sync Generator Schematic Diagram	4-12
Figure 4-10	Playfield Generator Schematic Diagram	4-13
Figure 4-11	Motion Object Generator Schematic Diagram	4-17
Figure 4-12	Video Output Schematic Diagram	4-18
Figure 4-13	Trak Ball™ and Switch Input Schematic Diagram	4-20
Figure 4-14	Audio Schematic Diagram	4-22
Figure 5-1	Final Assembly	5-2
Figure 5-2	Fluorescent Light Assembly	5-4
Figure 5-3	Control Panel Assembly	5-5
Figure 5-4	Trak Ball™ Assembly	5-6
Figure 5-5	Steering Board Assembly	5-8
Figure 5-6	Type B Power Supply Assembly	5-9
Figure 5-7	Coin Door Assembly	5-10
Figure 5-8	Basketball Game PCB Assembly	5-12
Figure 5-9	Audio PCB Assembly	5-16

location setup

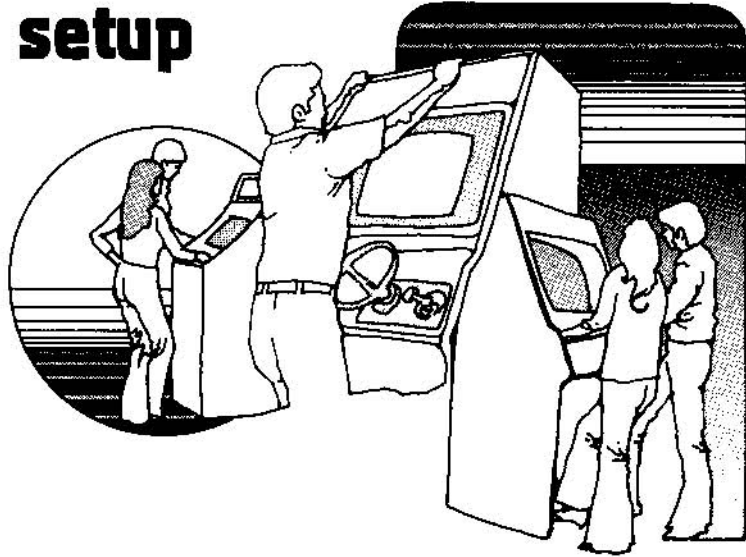

a. introduction

Basketball is a one- or two-player large-screen video game designed and made by Atari, Inc. It realistically simulates a "one-on-one" game between two basketball players who can shoot, dribble from one position on the floor to another, jump, block shots, steal the ball, and maneuver for the open shot. Each player controls one of the "men" displayed on the video screen, or if there is only a single player, the game's computer controls one man. The famous Atari Trak Ball™ also used in Football is employed to control the player images on the screen. The start/shoot/jump buttons are used to start the game after coins have been deposited, (see Figure 1-1), and during game play, to cause a man to shoot the ball or jump to defend against the other man's shots.

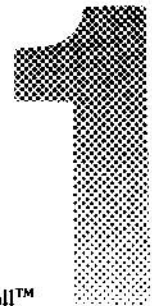

Basketball™

b. game inspection

Your game is manufactured ready to play upon removal from its shipping carton. Your cooperation is requested to supply the final touch of quality control to your game. Therefore, please follow these procedures to ensure that your game is in good condition:

1. Examine all external parts of the game cabinet for dents, chips, or broken parts.
2. After determining that the game has been received in good condition, unlock and open the rear access panel. Carefully inspect the interior and verify the following:
 - All plug-in connectors are firmly seated.
 - All integrated circuits on the game printed circuit board (PCB) are firmly seated in their sockets or soldered in place.
3. Check the power supply (located on the floor of the game cabinet), the two speakers, the player controls (Trak-Balls™ and start/shoot/jump buttons) and the TV monitor for secure mounting.
4. Note the location of the game's serial number — it is on the metallic label in the upper left corner of the cabinet. A serial number (not necessarily the same one) also appears in the corner of the game PCB that is between the two edge connectors. A drawing of this is on the inside front cover page. Please mention this number whenever you call your distributor for service.

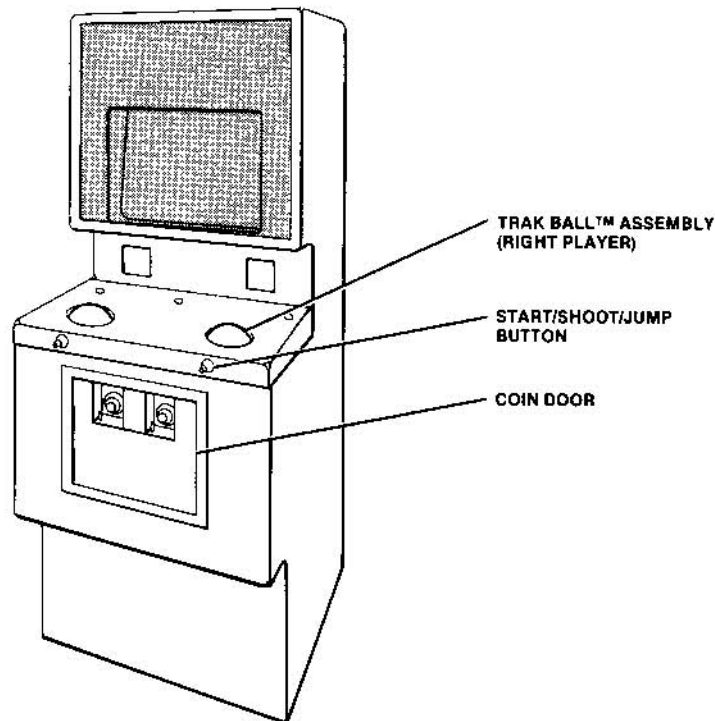

Figure 1-1 Control Panel and Player Controls

c. installation requirements

This game is shipped for operation at 110 VAC, 50/60 Hz. However, the power supply has four voltage-selection plugs that allow for the use of four different voltage ranges. Therefore, if your line voltage is 220 VAC, plug in the red plug. (See Figure 1-2)

1. Low Voltage Problems

If your game is set for 110 VAC (or 220 VAC) and your line voltage is usually below 100 VAC (or 200 VAC), you may experience a decrease in the size of the monitor picture and/or the game operation will be erratic (weird things will appear on the screen).

2. High Voltage Problems

If your game is set for 95 VAC (or 210 VAC) and your line voltage is usually above 110 VAC (220 VAC), the monitor picture size will increase, the game will run hotter, and the game will be prone to an increase in the rate of failures.

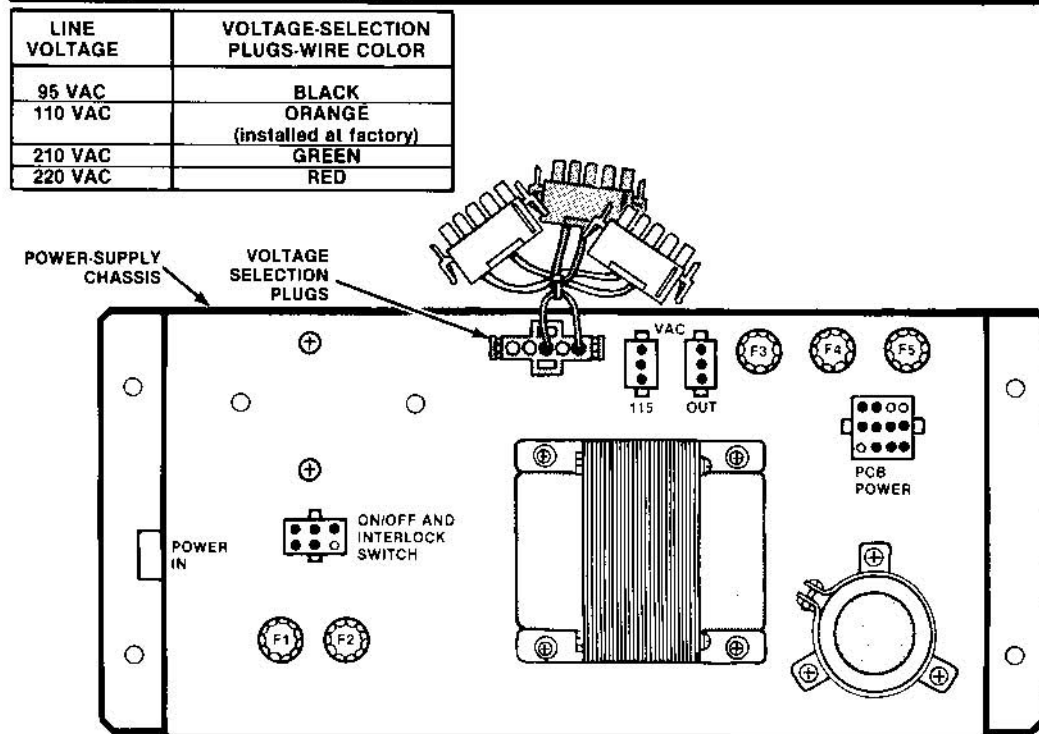
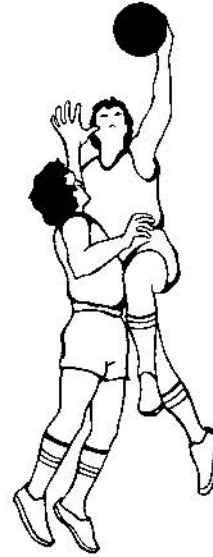

Figure 1-2 Voltage Selection Plugs

d. interlock and power on/off switches

1. Purpose of Interlock Switches.

Two interlock switches have been installed on your game to minimize the hazard of electric shock while you are working inside the cabinet (see Figure 1-3). One switch is located behind (inside) the rear access panel and the other behind the coin door. These switches remove all AC line power from the game circuitry whenever either door is opened.

Check for proper operation of the interlock switches by performing the following steps:

- Unlock and remove the rear access panel and open the coin door.
- Plug the AC line power cord into your wall outlet.

BE SURE THAT THE POWER SUPPLY VOLTAGE PLUGS ARE CORRECT!

(See section C of this chapter).

- Set the power on/off switch to the "on" position (see Figure 1-3).
- Close the access panel and coin door. The attraction lamp should light, and within 30 seconds, the TV monitor should display a picture.
- Slowly open either the coin door or the rear access panel, and watch the TV picture. It should go off, along with the attraction lamp, when either the door or panel is opened approximately one inch.
- If the results of this test are satisfactory, the interlock switches are operating properly. If they are not, check that the interlock switches are not broken from their mountings or stuck in the "on" position.
- Close and lock the rear access panel.

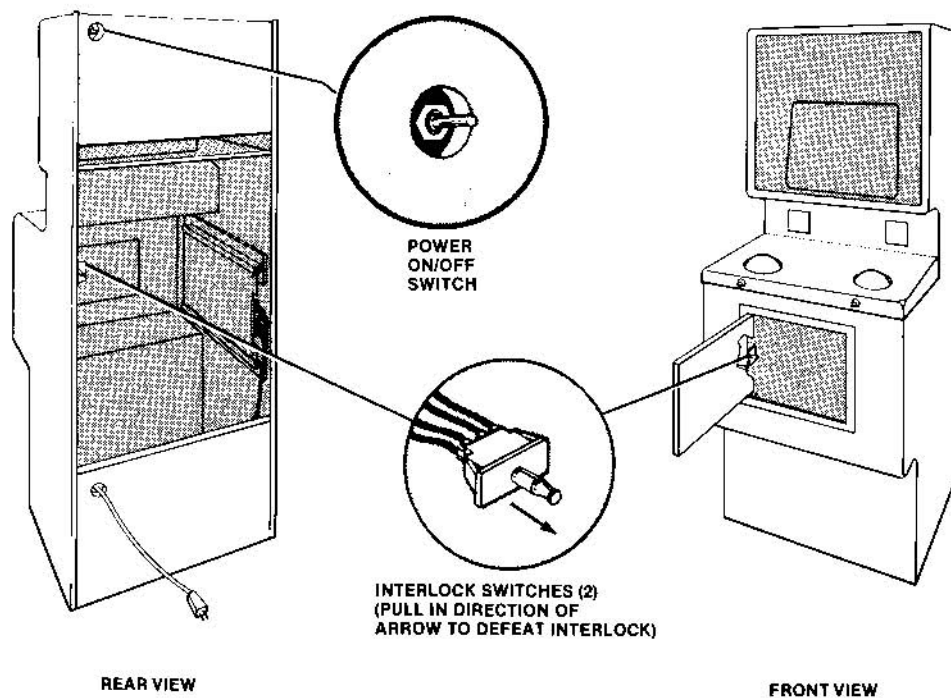

Figure 1-3 Power On/Off and Interlock Switches

a. self-test procedure

Your game will test itself and provide data to demonstrate that its circuitry and controls are working properly. This procedure uses the TV monitor and the speakers; no additional equipment is required. (See Figure 1-4 for location of the self-test switch.) To start the self-test procedure, slide the switch to its "on" position as shown in the figure. See Table 1-1 for further details and instructions on the self-test. We suggest that you run the test each time the coin box is emptied.

f. volume adjustment

The audio volume may be adjusted to suit your particular location and conditions. The volume control is located on the same printed circuit board as the self-test switch. See Figure 1-4.

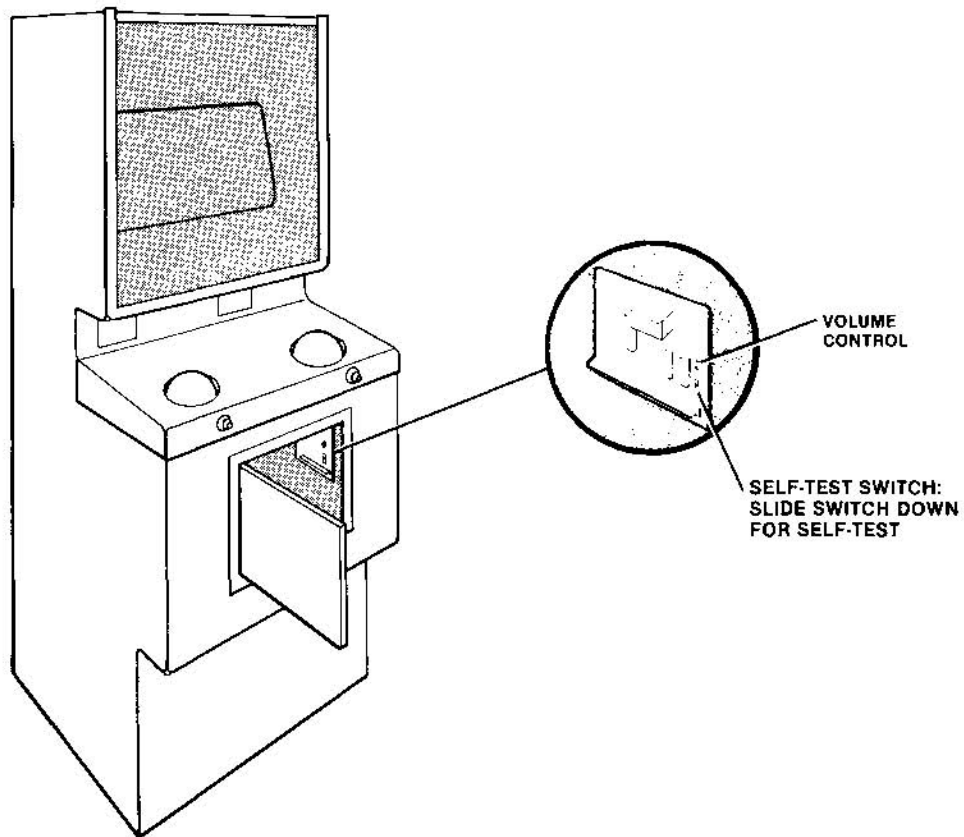

Figure 1-4 Volume Control and Self-Test Switch

Table 1-1 Self-Test Procedure

Test # and Name	Result if Test Passed	Result if Test Failed
1. ZERO PAGE RAM TEST	Automatically advances to the next test.	Low-pitched audio whistle; CRT will display "Z PAGE LOW NIB BAD" or "Z PAGE HIGH NIB BAD" followed by either the letter E or D. The letter indicates whether the faulty RAM chip is at D2 or E2.
2. PLAYFIELD RAM TEST	Screen displays "RAM OK ROM OK" and advances to next test.	Game will not respond if self-test switch is turned off. Audio whistle will be heard, and screen will display "RAM BAD" and one or more letters. See Table 1-2 for faulty chip isolation information.
3. ROM TEST	Automatically advances to next test (no screen or audio output).	Message from test #2 changes to read "RAM OK ROM BAD" followed by a single letter from A to P that tells you which ROM is bad. See Table 1-2.
4. PATTERN TEST 	The complete set of characters is displayed on the screen.	One or more characters not displayed or improperly displayed.
5. SWITCH/TRAK BALL/AUDIO TEST	<p>With all switches open, audio outputs a continuously rising tone. Closing any switch (2 start, 2 coin, 1 slam) will stop tone output, start crowd noise output at low level. LED is "on" when switch open, "off" when closed.</p> <p>TRAK BALL™: Rectangles respond horizontally and vertically to Trak Ball™ movements, black rectangle to left ball, white rectangle to right ball.</p> <p>AUDIO: The audio tone heard when two rectangles are vertically aligned indicates "dribble" sound effects working properly.</p>	<p>No rising tone, no crowd noise, LEDs do not light.</p> <p>Rectangles do not respond to Trak Balls™ or respond incorrectly as compared to description at left.</p>
NOTE: To return to Attract Mode, flip self-test switch to "off" position.		

Table 1-2 Faulty Circuits or Chips

SELF-TEST ROUTINE: RAM TEST		SELF-TEST ROUTINE: ROM TEST			
MONITOR DISPLAYS:	FAULTY CIRCUIT OR CHIP LOCATED AT:	MONITOR DISPLAYS:	FAULTY CIRCUIT OR CHIP LOCATED AT:		
			-01 PCB 1k x 4 PROMS	-01 PCB 2k x 4 PROMS	-02 PCB 4k x 8 ROMS
RAM BAD A	F3	ROM BAD A	R1	R1	D/E1
RAM BAD B	F5	ROM BAD B	L1	L1	D/E1
RAM BAD C	F3 and F5	ROM BAD C	L2	R1	D/E1
RAM BAD E	H3	ROM BAD D	F2	L1	D/E1
RAM BAD F	H5	ROM BAD E	N1	N1	C/D1
RAM BAD G	H3 and H5	ROM BAD F	J1	J1	C/D1
RAM BAD I	K3	ROM BAD G	N2	N1	C/D1
RAM BAD J	K5	ROM BAD H	J2	J1	C/C1
RAM BAD K	K3 and K5	ROM BAD I	P1	P1	F1
RAM BAD M	L3	ROM BAD J	H1	H1	F1
RAM BAD N	L5	ROM BAD K	P2	P1	F1
RAM BAD O	L3 and L5	ROM BAD L	H2	H1	F1
		ROM BAD M	M1	M1	B1
		ROM BAD N	K1	K1	B1
		ROM BAD O	M2	M1	B1
		ROM BAD P	K2	K1	B1

NOTE: When troubleshooting RAM or (P)ROM locations, always check the associated circuitry as well as the suspected memory chips.

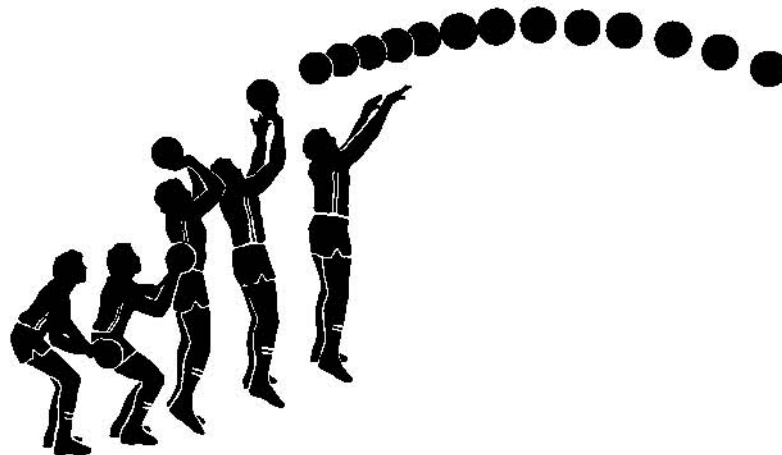

g. operator options

The operator options offer maximum player appeal for your game location(s). These options are listed in Table 1-3. They are preset for a certain game setup during production. To determine how the switches have been set for your game, compare the attract mode with the information in Table 1-3. Operator Option Settings.

To change the toggle positions of the switch assembly and set the desired options, you need not remove the game PCB (see Figure 1-5).

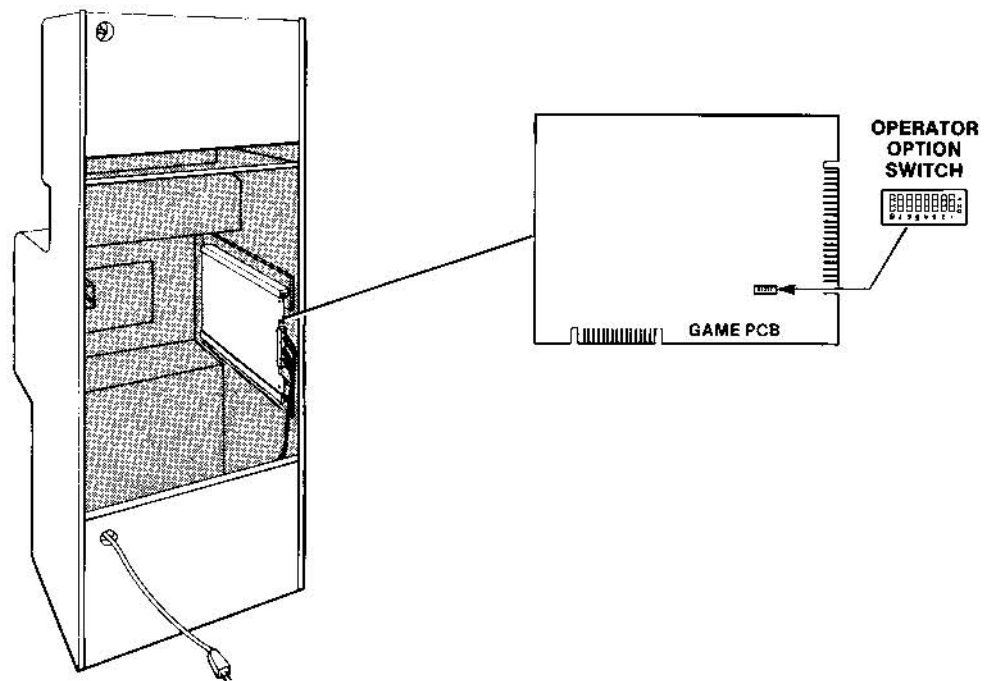
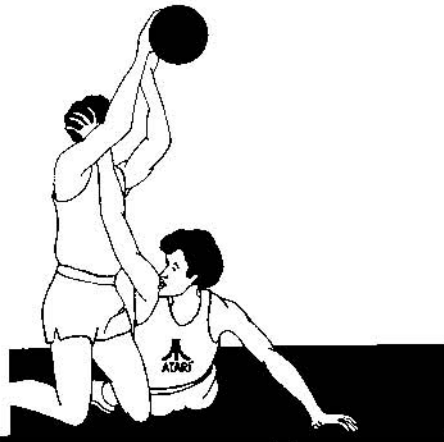
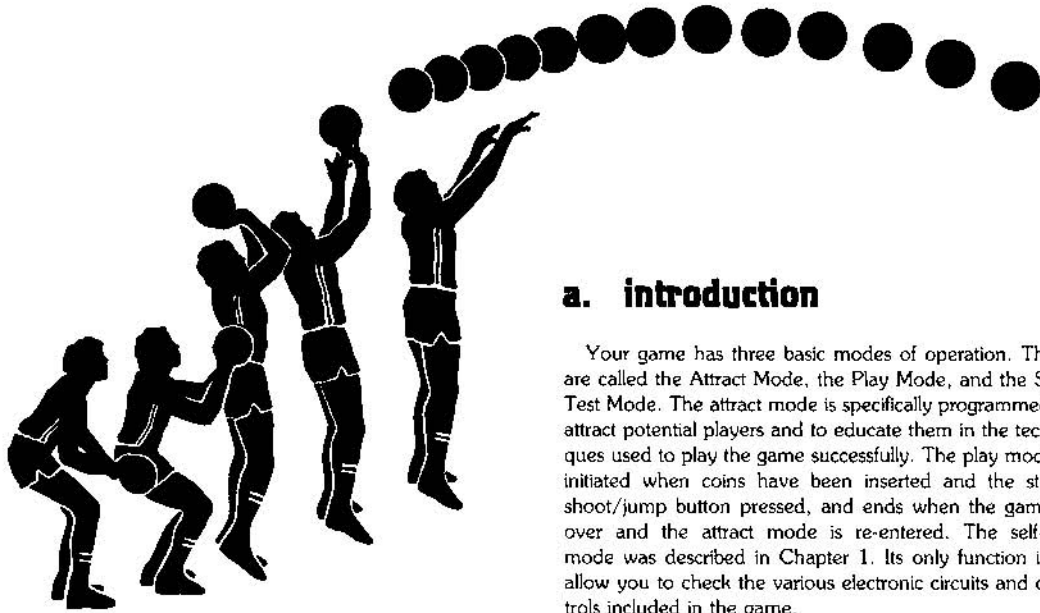

Figure 1-5 Operator Option Switches

Table 1-3 Operator Option Switch Settings

Option	Toggle No. & Setting of DIP Switch on PCB								Result of Setting
	8	7	6	5	4	3	2	1	
Coin Mode						OFF OFF OFF ON ON ON ON	OFF OFF ON ON OFF ON ON	OFF ON ON OFF ON ON OFF	Free Play 2:30/Credit* 2:00 Credit* 1:30/Credit* 1:15/Credit* 1:00/Credit* \$ 0:45/Credit* 0:30/Credit*
Game Instruction Language	ON OFF ON OFF	ON OFF OFF ON							English\$ German Spanish French
Dollar Coin Mode**				OFF ON OFF ON	OFF OFF ON ON				1 Coin = 6 Credits 1 Coin = 5 Credits 1 Coin = 4 Credits 1 Coin = 1 Credit\$
One or Two Coin Minimum			ON OFF						One Coin Minimum\$ Two Coin Minimum
<p>* A "credit" is a block of time for one or two players. \$ Indicates setting when game is shipped from Atari ** For left coin mechanism only</p>									



a. introduction

Your game has three basic modes of operation. These are called the Attract Mode, the Play Mode, and the Self-Test Mode. The attract mode is specifically programmed to attract potential players and to educate them in the techniques used to play the game successfully. The play mode is initiated when coins have been inserted and the start/shoot/jump button pressed, and ends when the game is over and the attract mode is re-entered. The self-test mode was described in Chapter 1. Its only function is to allow you to check the various electronic circuits and controls included in the game.

Basketball™



b. the attract mode

The attract mode is entered after game power-up, when exiting from self-test mode, and after the end of a game. Basically, this mode has two functions. First, by displaying two "men" shooting, tossing the ball, and the like, it acts as an attractive inducement to potential players. Secondly, the attract mode display aids the first-time player in learning how the game is played. He can learn that longer shots are "made" by allowing the shooter's arm to come up and back farther before releasing the ball by watching the graphics display during the attract mode. Short shots are released more quickly.

When sufficient coins have been deposited, the message PRESS START is also displayed. The message ADD COINS FOR MORE TIME is also displayed in the attract mode. This mode terminates upon pressing the start/shoot/jump button (if sufficient coins have been deposited) or throwing the self-test switch to self-test mode.

c. play mode

Play mode is initiated when both start/shoot/jump buttons are depressed, provided that the required minimum number of coins has been accepted by the game. A short tune is played, and both men appear on the screen. The ball drops onto the court from above to begin play. The player who gets the ball attempts to dribble into shooting position. Sound effects of the ball being dribbled accompany the action. The Atari Trak Ball™ is used for directional and speed control of the men displayed on the screen. Shooting (man

with ball) and jumping to block shots (man without ball) are done with the start/shoot/jump buttons.

If the defensive player can maneuver his man into position directly in front of the man *with* the ball, the ball can be "stolen". When the offensive player depresses his start/shoot/jump button, his man brings back his arm before shooting. When the button is released, the shot is made. The longer the button is held down before release, the farther the ball travels when shot. Each time a basket is scored, the player who made the shot is awarded two points. The scoreboard is at the top of the display. At the end of the game, the unit plays its short tune once again. If additional coins are not deposited before the game timer reads "0:00", the game returns to the attract mode, but the score continues to be shown.

If only one player is participating, he plays against the game's computer. In this case, the play mode is initiated by pressing only one of the start/shoot/jump buttons. If the second button is not pressed within a few seconds, the game will initiate play as a single-player game. The computer becomes "tougher" as the player begins to run up a score on it. If the player gets eight points ahead, the computer controlled "man" begins jumping to block shots. This provides a greater challenge to the player. In all other respects, the single-player game is the same as the two-player contest.

d. self-test mode

As mentioned, the self-test mode is for purposes of allowing the game to test itself without additional electronic or other equipment. See Chapter 1 for a complete description of this mode.

maintenance and adjustments

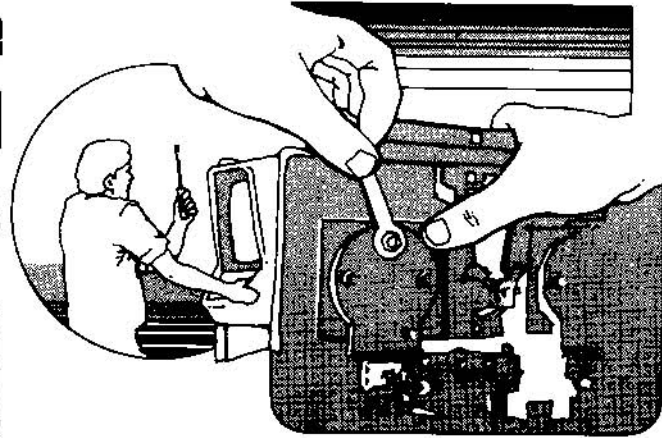
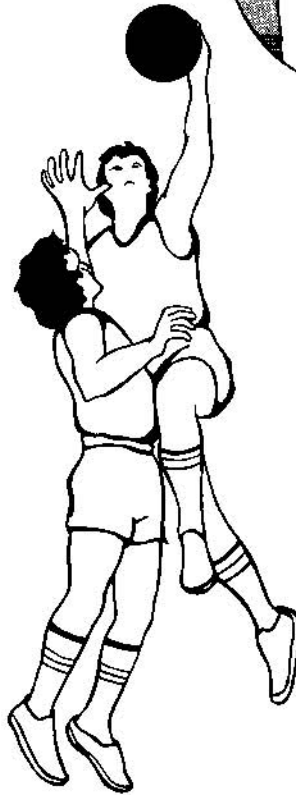

a. introduction

Due to its solid-state circuitry, this Atari game should require very little maintenance and only occasional adjustment. Information given in this chapter is intended to cover most servicing situations that may be encountered at the game site. The procedures described are sufficiently detailed to make them easily understandable by persons with only moderate background or technical training.

Basketball™



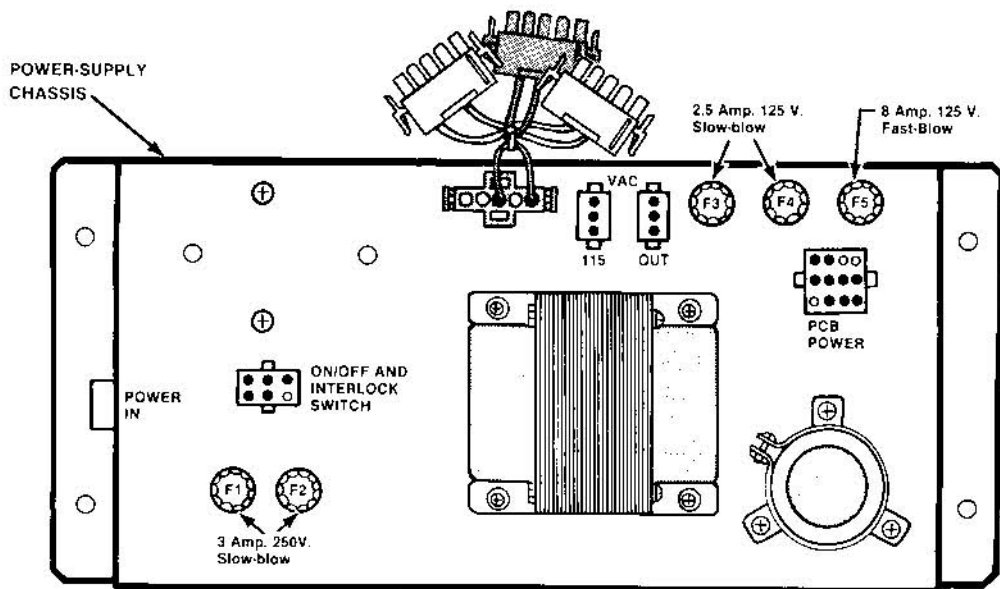

Figure 3-1 Game Fuses

b. cleaning

The exteriors of game cabinets and transparent plastic panels may be cleaned with any non-abrasive household cleaner. If desired, special coin machine cleaners that leave no residue can be obtained from your distributor. Do **NOT** dry-wipe the acrylic plastic panels, because any dust can scratch the surface and result in a "foggy" appearance that will seriously detract from the game's player appeal.

c. game fuses

The game contains a total of five fuses mounted in holders on the power supply chassis. These are accessible through the rear access panel. Replace fuses only with the same type and rating. See Figure 3-1 for location and rating of each fuse. Also see the manufacturer's manual for the TV monitor for fuse information on the monitor unit.

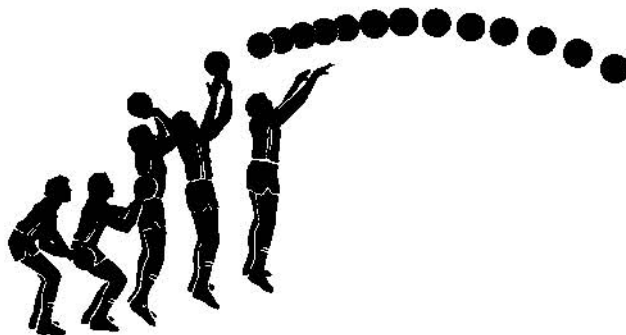

d. player control panel

To reach the two start/shoot/jump LED switches and the Trak Ball™ assemblies, the player control panel must first be hinged open as shown in Figure 3-2. Follow this procedure:

- Remove the three Allen-head cap screws from the top of the control panel.
- Gently lift the back edge of the control panel upward and away from the game. This will reveal the two Trak Ball™ assemblies and the LED start/shoot/jump buttons.

1. LED Start/Shoot/Jump Switches

The LED pushbutton switches on the front edge of the control panel have a very low failure rate, and if a malfunction is suspected, they should be tested before replacement. To test the LED switches, proceed as follows:

- Remove the wires from the suspected switch.
- Set the multimeter to the **ohms** scale.
- Set the meter to the $R \times 1$ position and "zero" it.
- Connect the meter leads to the appropriate switch contacts. (See Figure 3-3.)
- Check contacts by pushing and releasing the switch button for a very low resistance reading when closed and a very high reading when the switch is released (open).
- If the contacts do not operate "sharply" or if they always stay open or closed, replace the switch as described in Figure 3-3.

2. Trak Ball™ Assemblies

The two Atari Trak Ball assemblies with their associated printed circuit boards (two per assembly) are reached by opening the player control panel. To remove a Trak Ball assembly, disconnect steering PCB connectors and remove three assembly retaining screws: see Figure 3-4.

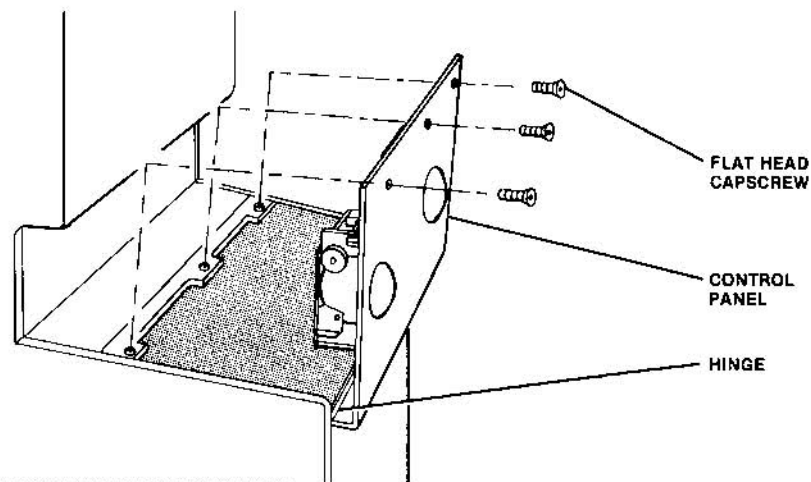

1. REMOVE THE THREE FLAT HEAD CAPSCREWS
2. HINGE THE CONTROL PANEL FORWARD AS SHOWN BY ARROW

Figure 3-2 Hinging the Control Panel Open

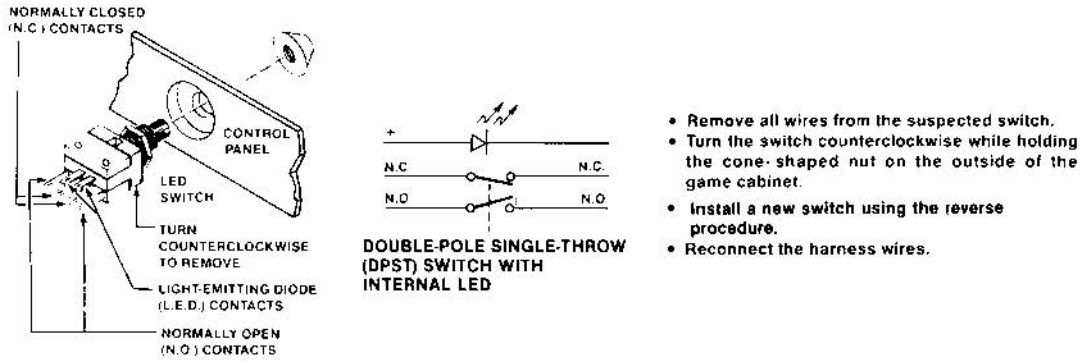

Figure 3-3 LED Start Switch Testing and Replacement

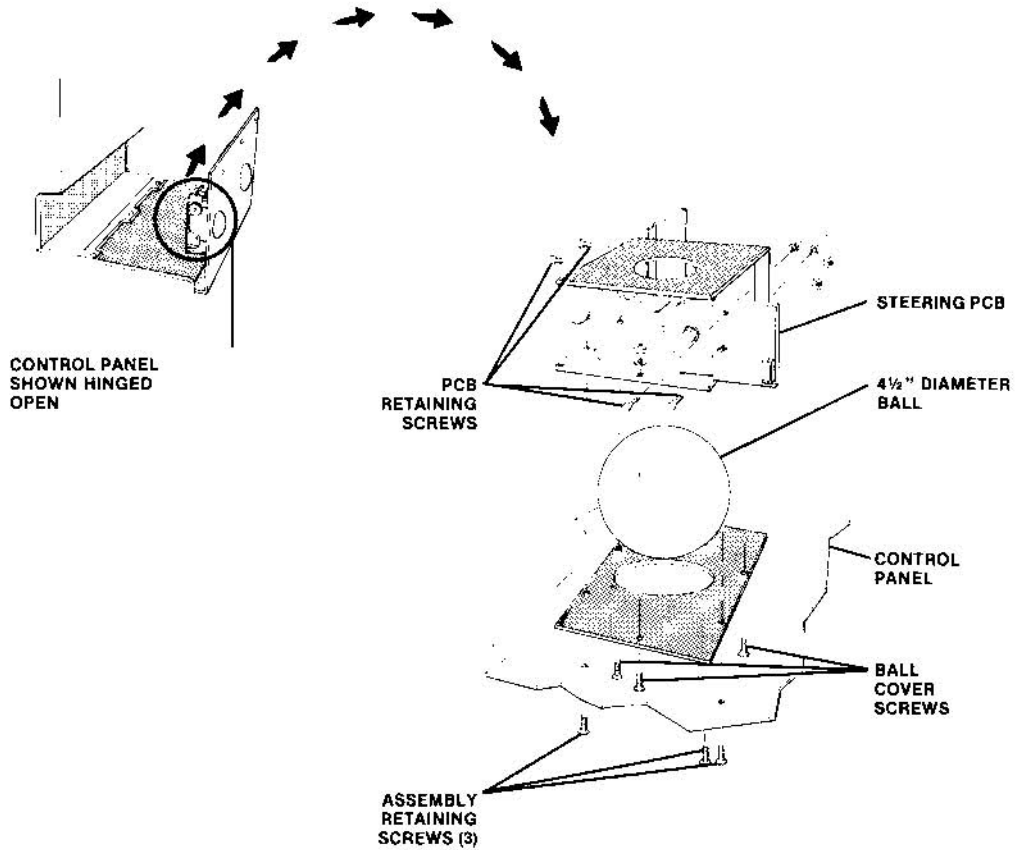

Figure 3-4 Trak-Ball™ Assembly Removal

e. loudspeakers

The only probable cause of failure of either of the two loudspeakers is an electrical short or a ruptured cone (both highly unlikely). The speakers are located directly below the monitor shelf, and may be reached through the rear access panel of the game.

f. fluorescent lamp

To replace the fluorescent lamp, proceed as follows:

- Remove the hex socket cap screws (there are three) from the top of the game.
- Lift off the top attraction panel retainer strip, being careful not to let the panel fall forward from the game.
- From the front of the game, lift the panel upward and away from the game.
- With the panel removed, the 24" fluorescent tube can be replaced in the normal manner.
- Replacement of the panel is the opposite of the above steps.

g. tv monitor removal

The TV monitor may need to be removed for service. This is done through the front of the game as shown in Figure 3-5. Proceed as follows.

CAUTION

Hazardous or startling high voltage potential exists in any TV device, even with power disconnected. Use extreme care not to contact electrical parts on the chassis with the hands or metal objects held in the hands!!!

- Unplug the game from the wall plug.
- Unlock and remove the rear access panel.
- Remove the attraction panel as described in section F of this chapter.
- Lift out the cardboard bezel from its position in front of the monitor.
- Remove the four woodscrews and the two corner securing brackets.
- From the rear of the cabinet, remove the two wing nuts and two hex nuts, four lock washers and four flat washers from the carriage bolts that secure the TV monitor to its supporting shelf.
- Unplug the TV monitor connector from the back of the monitor.
- Remove the mounting bolts, and slide the monitor off of its shelf and out through the front of the game cabinet.
- After service/repairs, replace the monitor by reversing the above steps. Note that the wing nuts go on the front two bolts, and the hex nuts on the rear bolts.

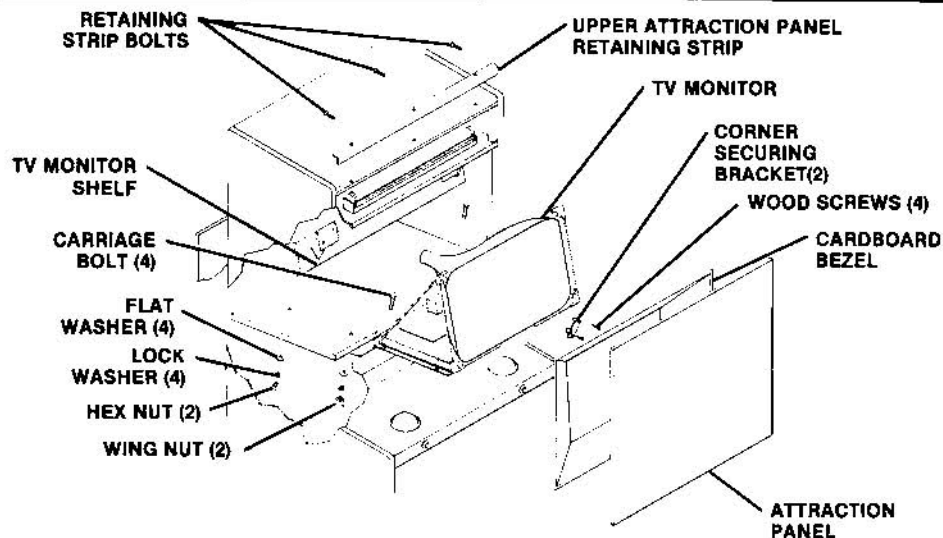

Figure 3-5 Removing the TV Monitor

h. game printed circuit board

You may wish to remove the game's printed circuit board (PCB) for service or inspection. To do this, proceed as follows:

- Switch the game power off and open the rear access door.
- Locate the screw that secures the game PCB in its slots (see Figure 3-6) and remove it.
- Carefully slide the PCB out of its slots, and unplug the edge connector. Be careful not to twist the board, as this may loosen connections or components.
- Perform the maintenance, etc. as required.
- Replace the PCB, making sure that the edge connector is properly plugged in. Note it is keyed to fit in only one position, so if it doesn't slip on easily, don't force it!
- Replace the securing screw through the hole in the PCB.
- Close and lock the rear access panel.
- Turn the power switch on and check that the operation of the game is correct (by playing the game).

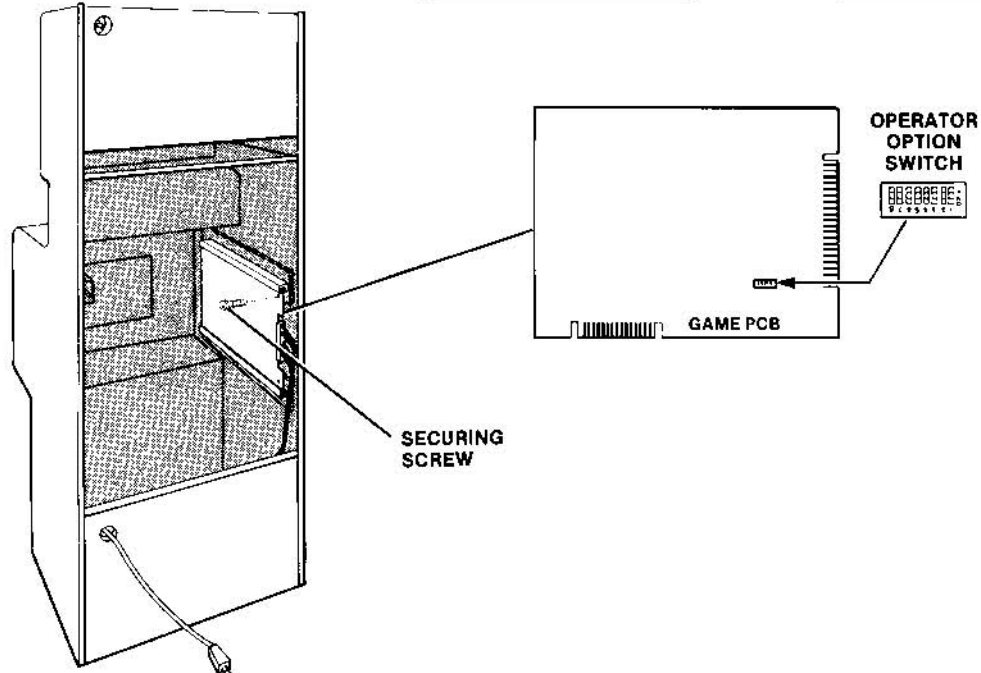
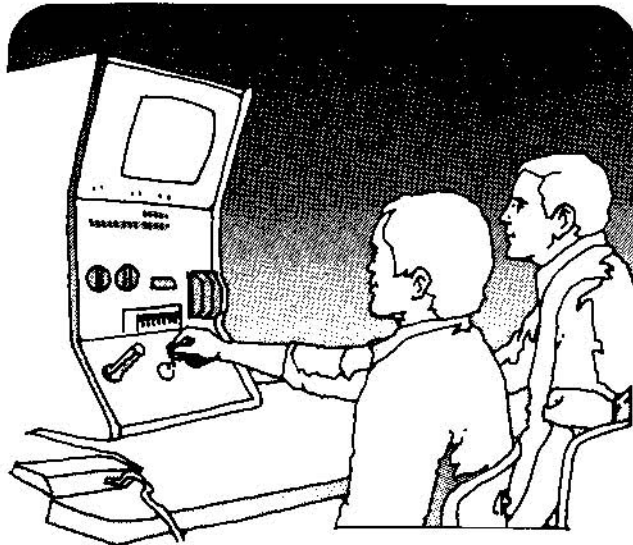

Figure 3-6 Removing the Game PCB

details of electronic operation



a. general information

This chapter provides a general overview of the operation of the game printed circuit board (PCB) electronics. It also goes into specific detail of the various circuits to explain to an individual of moderate technical background how these circuits should perform. This information has been organized with emphasis placed on troubleshooting the game PCB, circuit by circuit.

Figure 4-1 illustrates the major components, including all controls remote to the game PCB. The function and direction of signals to and from these various controls is also shown.

The PCB block diagram in Figure 4-2 illustrates the division and function of the various circuits located on the game PCB and how they are controlled by the microprocessor. Refer to Figure 4-2 as you go through the following circuit descriptions.

The functional operation of the game PCB begins with the microprocessor (or MPU) circuitry. As you read the various circuit descriptions, you will learn how the MPU receives its sequential program instructions from ROM memory and how it carries out these instructions through the use of RAM memory (Section C); how it reads in the game switches (Section H); outputs its instructions and calculations to the other PCB circuitry such as the playfield generator (Section E), the motion object generator (Section F), and the audio generator/mixer (Section I).

A description of the standard Atari sync generator (Section D) is also included. This is the only PCB circuitry that functions independently of microprocessor control.

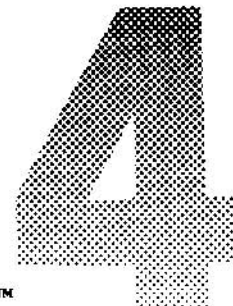

Basketball™

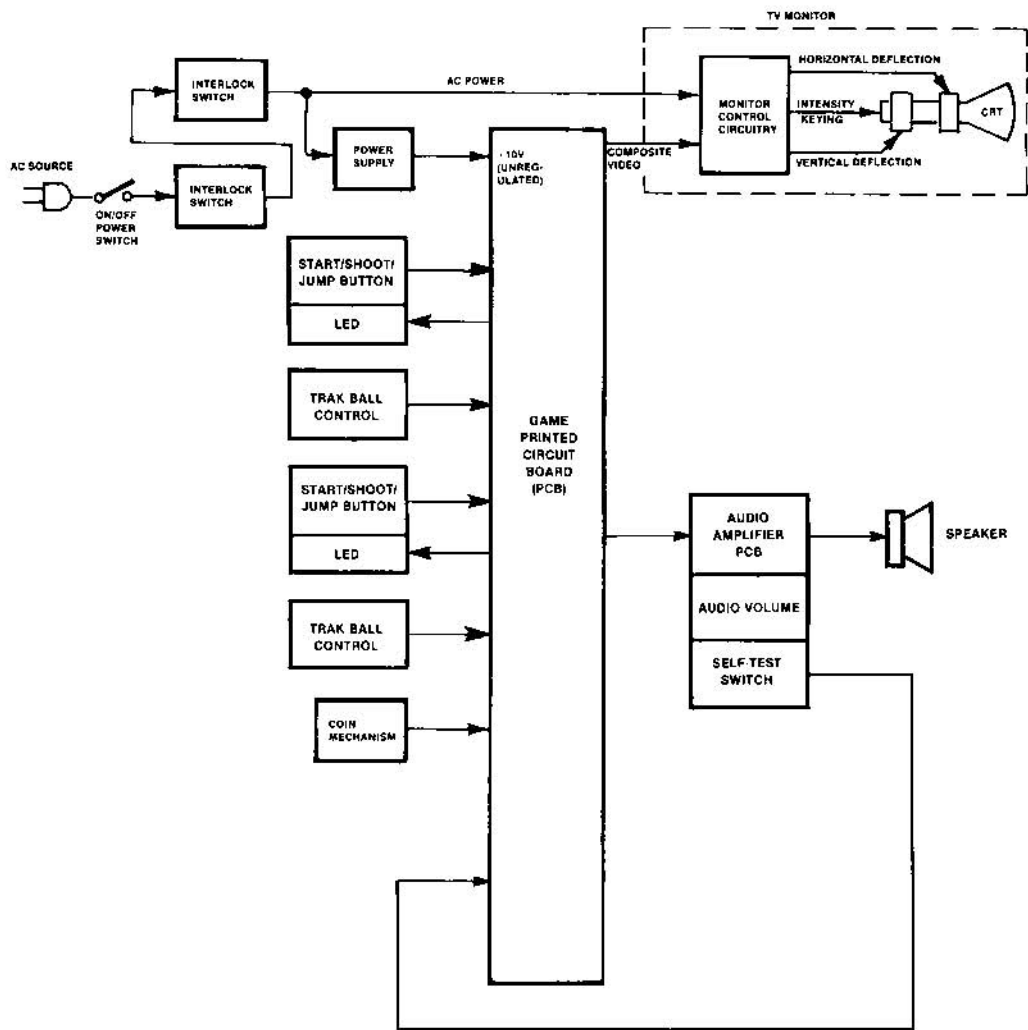

Figure 4-1 Game Block Diagram

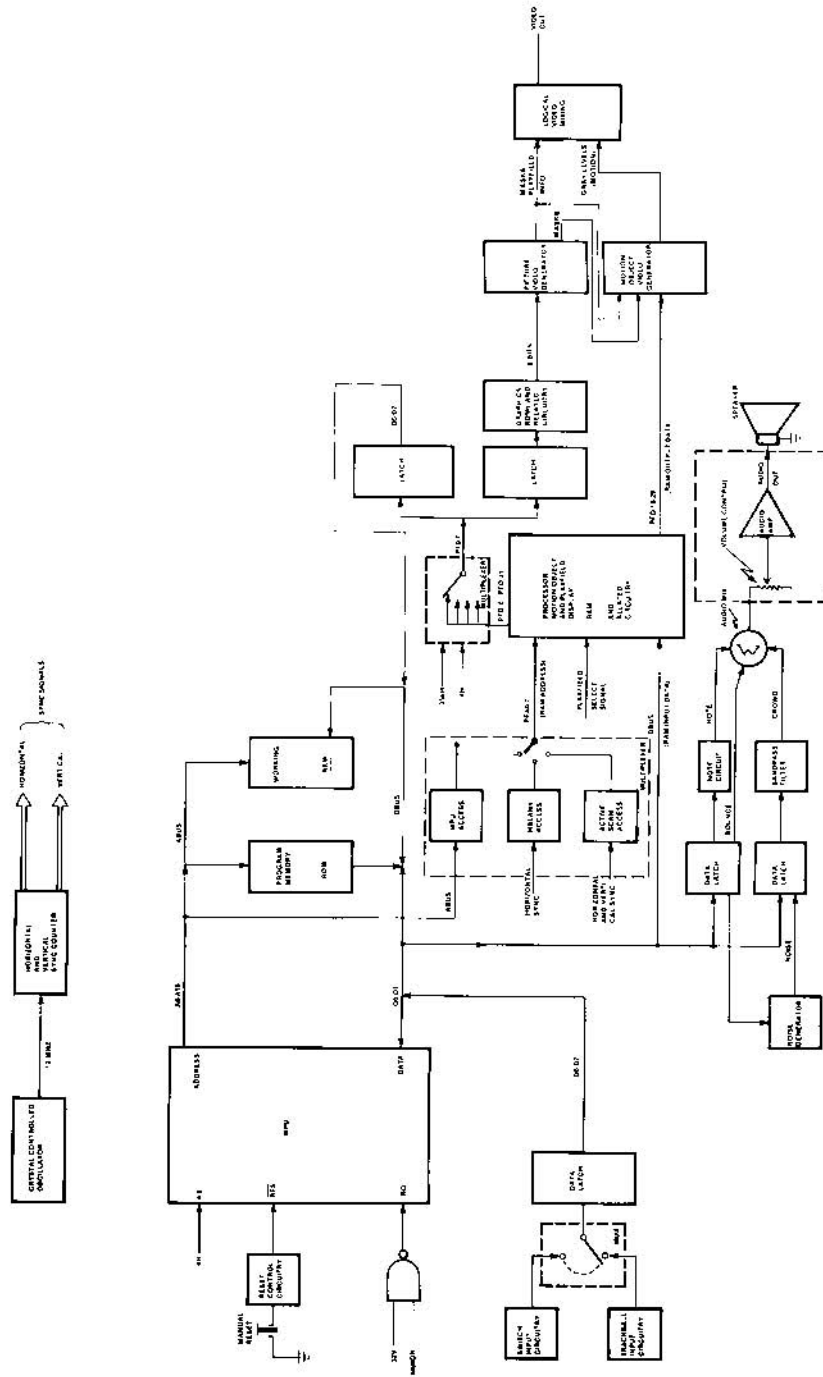

Figure 4-2 Game PCB Block Diagram

4-4 Basketball™

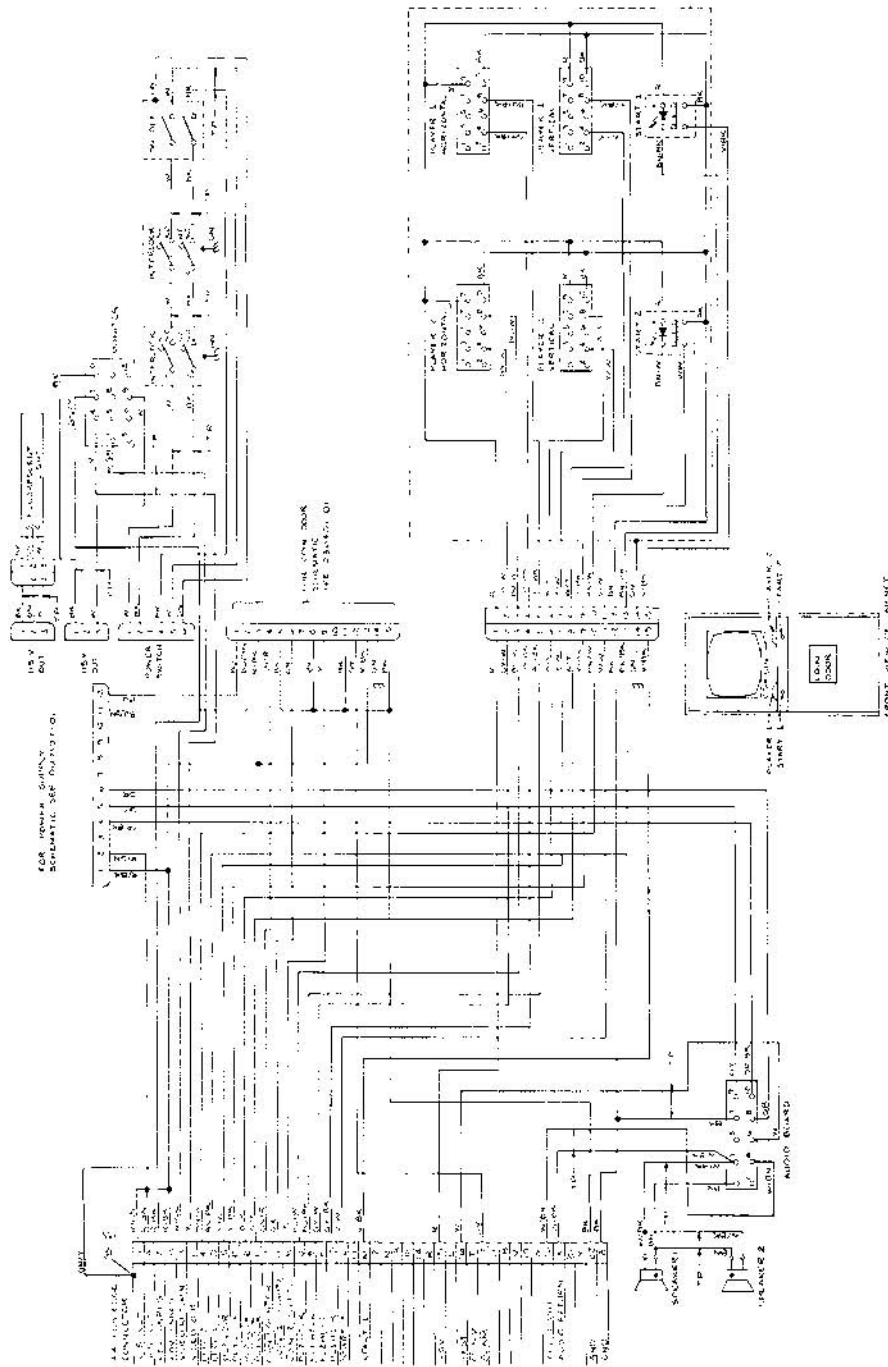

Figure 4-3 Game Wiring Diagram
034540-01A

b. power supply

The power supply provides all necessary game power as shown in Figure 4-3.

The game PCB receives an unregulated +10 volts DC at pins B and 2 of the PCB edge connector. The +10 volts

DC is rectified and filtered in the power supply assembly and regulated to a stable +5 volts DC by the LM323 on the game PCB. The regulated +5 volts DC is distributed throughout the PCB to power all logic circuits (see Figure 4-4).

The unregulated +10 volts DC also powers the LM324 audio amplifier circuits in the audio circuitry.

Coin Door

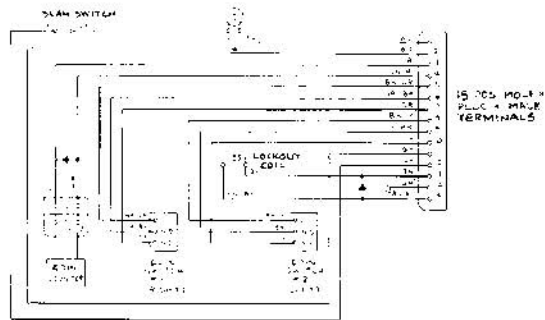

Power Supply

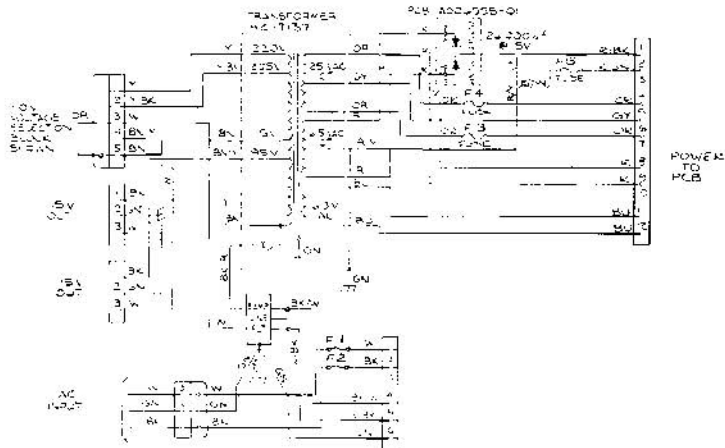

Figure 4-3 (Continued)

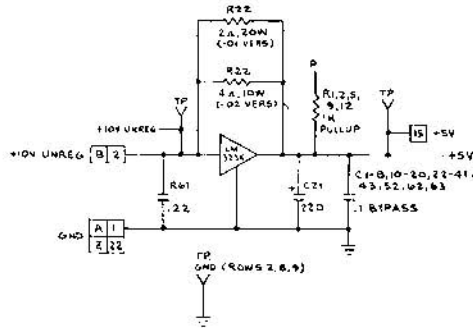

Figure 4-4 Game PCB Power Distribution
(Part of Game PCB 034268-XX A)

c. microcomputer circuitry

The heart of the game PCB is the microcomputer circuitry. A brief description of the major components and their functions is provided in the following paragraphs. Note that the microprocessor components include the following:

1. MPU at location C3, address buffers at B2 and C2, and data buffers at E3 and E5 (See Figure 4-5)
2. ROM memory at locations B1, C/D1, D/E1, and F1 for the -02 version, or PROM memory at F2, H1, H2, J1, J2, K1, K2, L1, L2, M1, M2, N1, N2, P1, P2, and R1 for the -01 version (See Figure 4-6)
3. RAM memory F3, F5, H3, H5, K3, K5, L3, and L5 (See Figure 4-7)
4. Address decoding circuitry C4, M6, M7 and associated gates (See Figure 4-8)
5. Watchdog reset counter C5 and associated circuitry (See Figure 4-4)

MPU, ROM, and RAM

(See Figures 4-4, 4-5 and 4-6)

The microprocessor is the "master controller" of all action that takes place in the game circuitry. Upon initialization, the MPU (via ABUS0 thru ABUS15) addresses data locations in the program ROMs or PROMs. The data in the addressed locations then travels to the MPU via the 8-bit data bus (D0 thru D7). The MPU decodes this data to determine what action it is to perform next (i.e., "read coin switch 1," "JUMP",

etc.). The MPU uses RAM memory to temporarily store information which it will later recall. The MPU is capable of writing (or putting data into) the RAM and then later reading (pulling data out of the RAM, via address bus (ABUS0 thru ABUS15) and bi-directional data bus (D0 thru D7).

Address Decoding

(See Figure 4-7)

The MPU address decoding circuitry performs the critical function of turning on or enabling the appropriate game circuitry (i.e., RAM, ROM, latches, etc.) at the correct time, so that information can be transferred back and forth between the game circuitry and the MPU. Table 4-1 is the memory map for this game.

Φ 0 Clock Driver

(See Figure 4-5)

The basic operating frequency of the microprocessor is established by its Φ 0 input (on pin 37 of the MPU). The MPU runs at an operating frequency of 750kHz. Examination of the MPU Φ 2 output waveform (pin 39) with an oscilloscope should show a signal with a period of 1.33 microseconds. (The period of any periodic waveform is the measurement of the time it takes to complete one full cycle.) The 750kHz clock outputs are generated by the 4H signal. This 4H frequency is generated by the horizontal sync counter R4 to produce the Φ 0 clock input. (See Figure 4-8, Φ 0 Clock Driver Signal.)

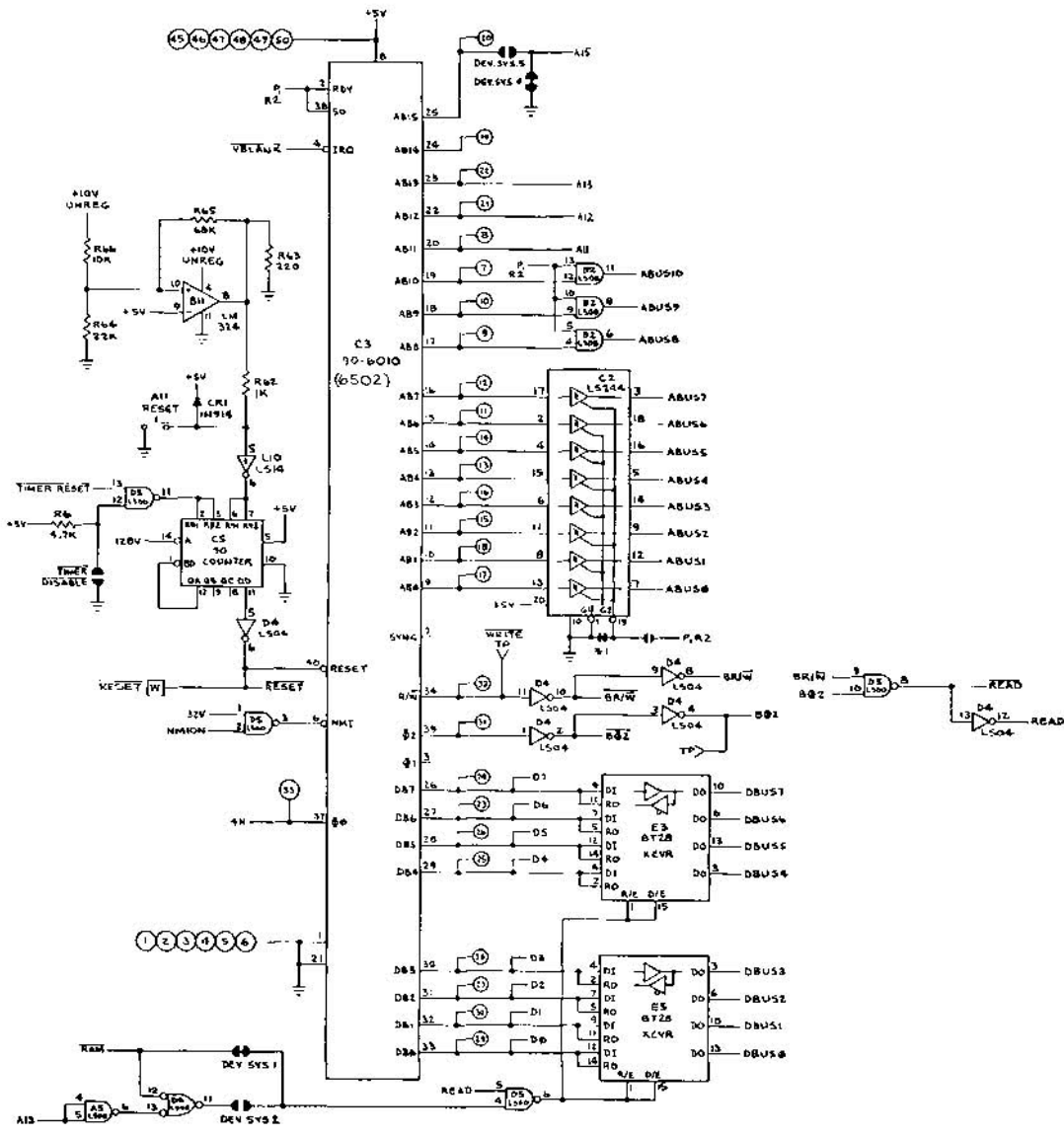

Figure 4-5 MPU Circuit Schematic Diagram
(Part of Game PCB 034268-XX A)

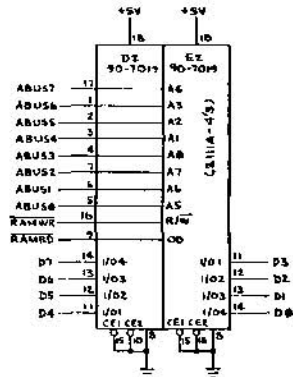

Figure 4-7 RAM Memory Schematic Diagram
(Part of Game PCB 034268-XX A)

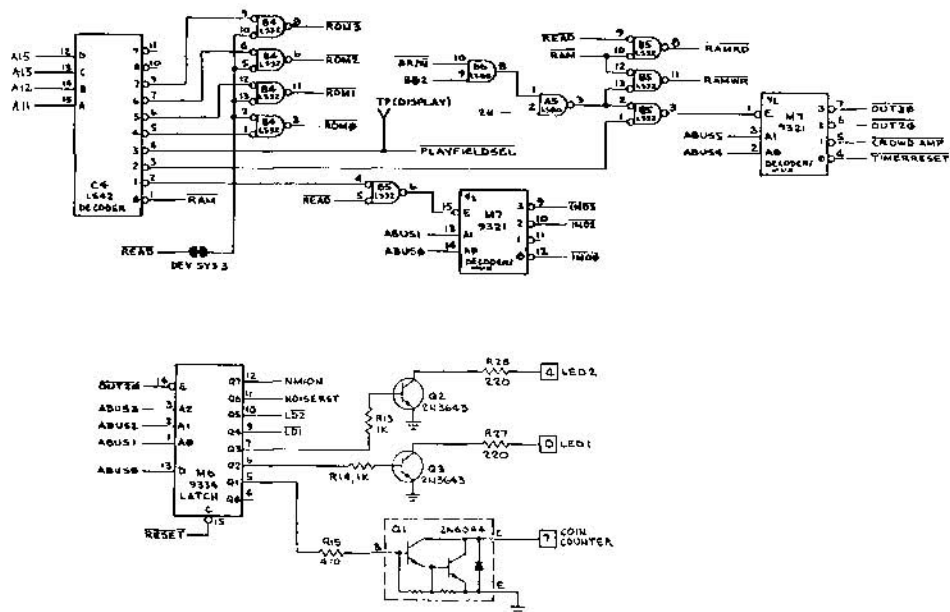

Figure 4-8 Address Decoding Schematic Diagram
(Part of Game PCB 034268-XX A)

Watchdog RESET

(See Figure 4-4)

The reset counter in the microprocessor control circuitry is a 4-bit decade counter, C5. The Q_0 output of this counter is the $\overline{\text{RESET}}$ signal to the MPU. Counter C5 counts how many times the 128V signal changes states. On every high-to-low transition of 128V, the counter advances to the next count in its sequence. Meanwhile, the $\overline{\text{TIMER RESET}}$ signal, generated by the MPU at various times during its normal instruction sequence, is resetting the counter back to zero. If for some reason, the MPU program has strayed from its intended instruction sequence and the $\overline{\text{TIMER RESET}}$ signal does not occur before this counter counts up to a point where the Q_0 output goes high, a $\overline{\text{RESET}}$ signal is generated to the MPU. The $\overline{\text{RESET}}$ signal causes the MPU to restart its instruction sequence from the beginning of the program.

d. sync generator

(See Figure 4-9)

The basic frequency of the sync generator is a 12.096MHz clock, generated by a crystal-controlled oscillator consisting of crystal Y1, inverter R3 and several discrete components. The output of the oscillator is 12MHz. Examination of this signal with an oscilloscope (at pin 4 of R3) should show a period (or one cycle) of approximately 83 nanoseconds (.083 microseconds).

This base frequency is then divided down by binary counters R4, P4, and N4. These provide the various horizontal synchronization frequencies (1H thru 256H). The final output of this horizontal counter chain is 256H (at pin 13 of N4). This signal is, in effect, a division of the base frequency by 768, or 15,750 Hz. The period of 256H is about 63.5 microseconds (15,750 Hz). The 256H signal, as well as other horizontal signals, are used to generate the H BLANK and H SYNC timing pulses at flip-flop P5. See Figure 4-9, Horizontal Sync Timing Diagram for the relative timing of these waveforms.

The H SYNC signal is used to clock two stages of vertical sync counters P6 and N6. The H SYNC signal is divided down by these counters to form the various vertical synchronization frequencies (1V thru 128V). These two stages are used, in effect, to do a divide by 262 of the H SYNC signal. This results in the final output of these counters (128V at pin 11 of N6) of 60 Hz (the period is approximate-

ly 16.6 milliseconds). The various vertical frequencies address a sync PROM (N5) whose data is latched at the output of P7. The outputs of this latch are the various polarities and phases of the vertical timing frequencies used to synchronize the TV monitor display. See Figure 4-9, Vertical Sync Timing Diagram, for the relative timing of these waveforms.

The end result of the horizontal and vertical timing waveforms is to synchronize the TV monitor display. This display consists of 262 horizontal lines per frame, with each line being the time equivalent of 768 (12MHz) clock pulses. Each frame is repeated 60 times per second providing the necessary frequency of display refresh to provide a stable, non-flickering display.

e. playfield generator

(See Figure 4-10)

The Playfield generator generates the playfield video. The video is actually generated by the data stored in the graphics ROM comprised of ROM devices A/B6 and C6. (See Figure 4-13). This ROM video information is addressed by data obtained from the playfield display RAM.

The alpha and numerics and the basketball court picture components that make up the playfield picture are displayed as 8 line by 8 bit blocks of video on the TV monitor screen. The microprocessor loads the playfield location bits into the RAM. The RAM outputs (PFD0 thru PFD31) are then multiplexed through data selectors/multiplexers F4, H4, J4, and K4 and temporarily latched at the outputs of latches F6 and F7 at the rising edge of 4H clock. The latched data bits then address the graphics ROM A/B6 for one of 64 different pictures stored in it. The vertical signals (1V, 2V, 4V) determine which of 8 lines of the character is currently being addressed.

The order of the picture data from the graphics ROM is selected by the picture reflect signal (PIC7) input to data selector/multiplexers A8 and B8. The picture data output is serialized by shift/register A9.

The method by which the MPU writes the appropriate playfield data to each RAM location and then the horizontal and vertical timing signals read this data out for actual video generation is known as "cycle sharing". The circuitry that controls this cycle sharing technique selects one of 3 sets of addressing information to address the display RAM.

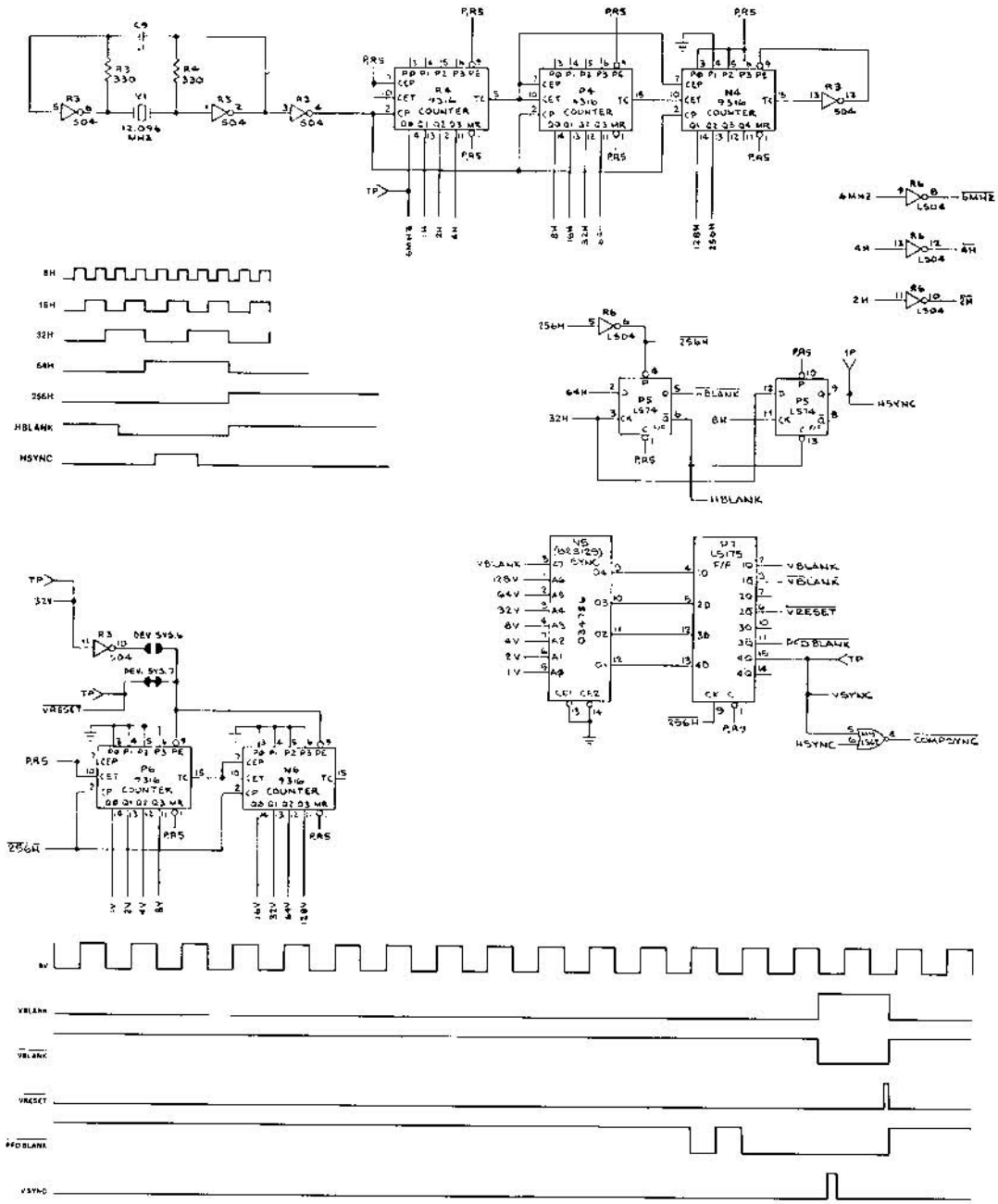

Figure 4-9 Sync Generator Schematic Diagram
(Part of Game PCB 034268-XX A)

This circuitry functions as follows:

1. When $\overline{4H}$ is low, the MPU address bus (ABUS2 thru ABUS9) addresses various playfield display RAM locations, and writes appropriate playfield picture codes into them via the MPU data bus (DBUS0 thru DBUS7).
2. When $4H$ and $\overline{256H}$ is low, the vertical sync signals (8V, 16V, 32V, 64V, 128V) and the horizontal sync signals (32H, 64H, 128H) address the playfield RAM through buffers N3.

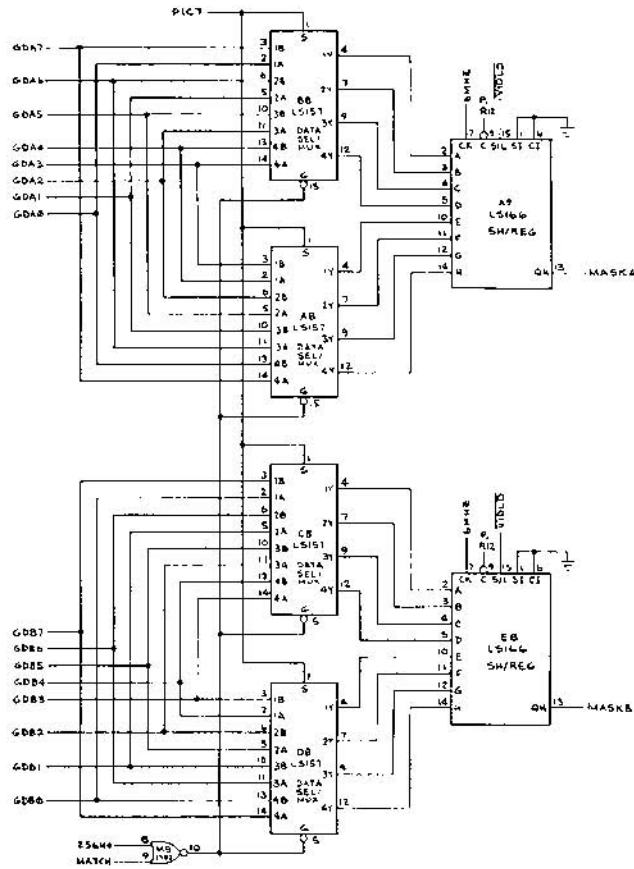

Figure 4-10 (Continued)

The data is read out of the RAM by the horizontal and vertical sync signals, and the appropriate byte of the 32-bit PFD word is selected by data selectors/multiplexers F4, H4, K4, and L4. The picture codes (PF0 thru PF7) always correspond to the portion of the monitor display currently being scanned. These picture codes address one of sixty-four 8×8 pictures stored in graphics ROMs A/B6. The output of the ROM is then converted to serial video (MASKA) information by shift register B8 and gated into the logical video mixer to generate composite video.

f. motion object generator

(See Figure 4-10 and 4-11)

For each motion object to be displayed, the MPU writes four bytes of data into the playfield display RAM. As with the playfield generator circuitry, when 4H is low, the MPU address bus (ABUS2 thru ABUS9) addresses specific RAM locations and appropriate motion object codes are written into them via the MPU data bus (DBUS0 thru DBUS7). The four bytes of data stored for each motion object are: 1) the vertical position of the object, 2) the type of object it is, 3) the horizontal position of the object, and 4) the "color" of the object. These four pieces of information are then accessed by the motion object generator as follows:

1. During the horizontal blanking period before each scan line, the vertical sync count is compared to the vertical position of each motion object stored in the RAM. This is done by adders H6 and J6 which compare vertical sync with PFD8 thru PFD15. If a motion object is to be displayed on that scan line, a MATCH signal is generated at E9 pin 8, after a delay of one 4H clock pulse.
2. Graphics ROMs address GA5 through GA8 is latched at the output of flip-flop F6 along with the MATCH signal. This part of the address byte defines the motion object to be output from the graphic ROMs. The actual line of the motion object to be

scanned is latched at the output of flip-flop H7 (GA0 through GA4). The MATCH pulse enables data selector/multiplexers A8, B8, C8, and D8 to pass sixteen bits of video data from graphics ROMs A/B6 and C6 to the inputs of shift registers A9 and E8. When the VIDLD pulse occurs, the graphics ROMs' data output is loaded into the shift registers.

3. The third byte of RAM data determines the horizontal position of the motion object. This RAM data (PFD16 thru PFD23) is latched by K6 and loaded into horizontal position counters L6 and K7. The horizontal location address generated by these counters then addresses high-speed VIDEO RAMs J8 and K8. These RAMs are now loaded with the video data for the particular motion object from shift registers A9 and E8 (which were loaded from the graphics ROM in the previous step).
4. The fourth byte of RAM data for each motion object determines the various shades of color in which that object is to be displayed. This data (PFD24 thru PFD29) is latched by L8 and M8 and used to determine the combination of video data loaded into the high-speed video RAMs (in the previous step).

In review, all four of the previous steps occur during the HBLANK period preceding each horizontal scan line. The proper motion object picture, with the proper "color shading" was loaded into the high-speed VIDEO RAMs. The horizontal and vertical location of the motion object has been determined by the portion of this RAM into which it was loaded. The motion object is now ready to be displayed on the TV monitor. When HBLANK ends, L6 and K7 are reset and allowed to sequentially count up to their maximum count. The outputs of these counters address the high-speed video RAMs (J8 and K8). When the RAM address encounters stored video information, the motion object video is output as GRYLVL0 and GRYLVL1 and sent to the video summing circuit. The combination of these two "grey level codes" determine the shape and color of the different motion objects seen on the TV monitor.

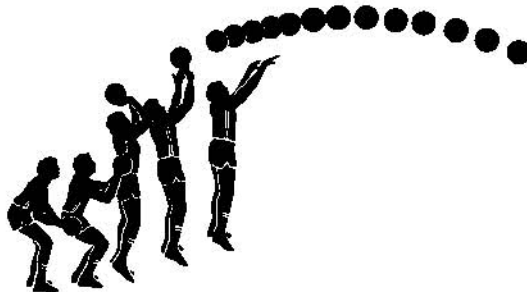

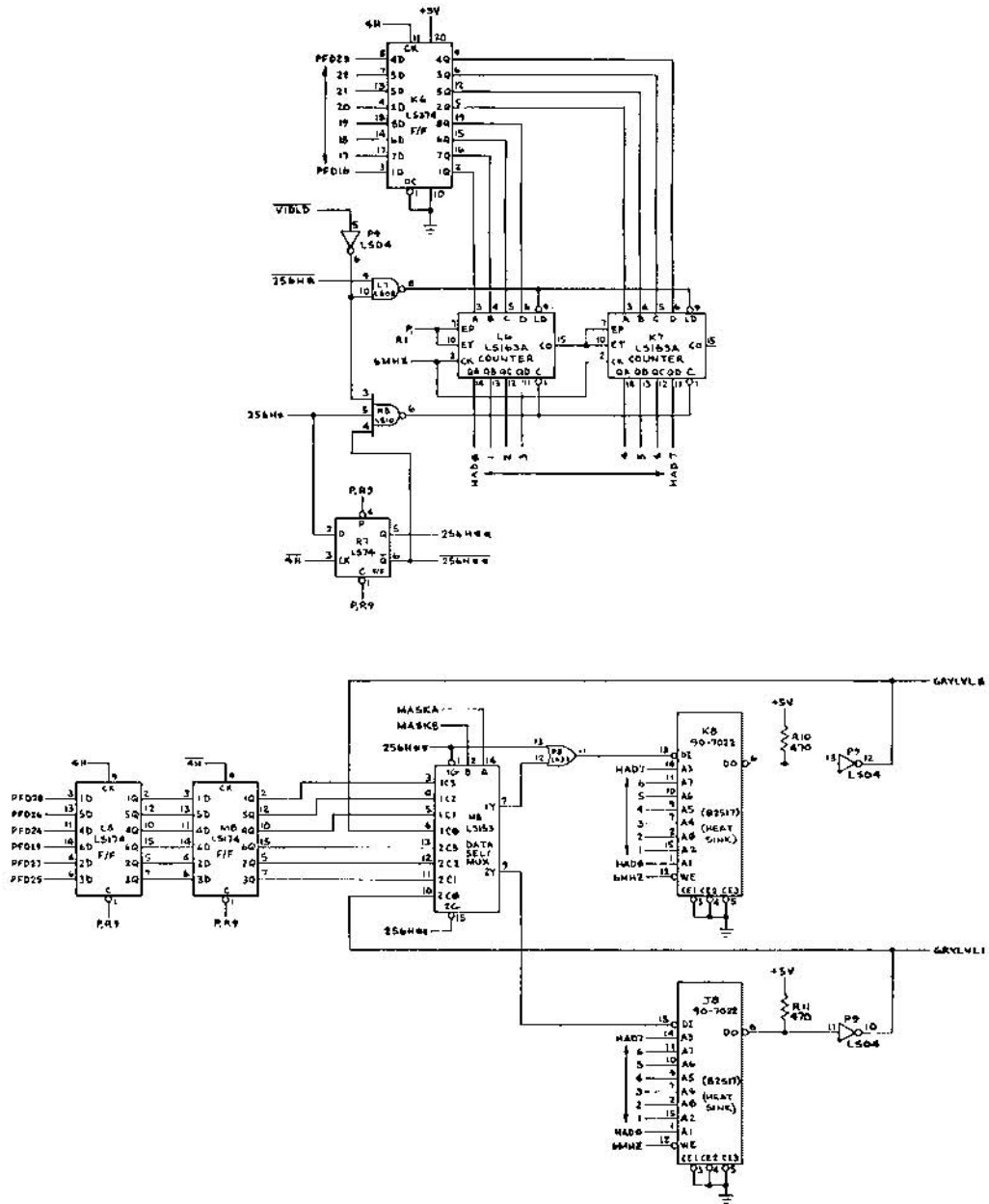

Figure 4-11 Motion Object Generator Schematic Diagram
(Part of Game PCB 034268-XX A)

g. video summing circuit

(See Figure 4-12)

The video summing circuit receives MASKA from the playfield generator and GRYLVL0 and GRYLVL1 from the motion object generator. These three signals are summed through various gates into flip-flop P10. The actual video to be displayed on the TV monitor is determined by the combination of the two signal outputs of this flip-flop. These outputs (P10, pin 5 and P10, pin 9) are mixed with composite sync COMPSYNC for a composite VIDEO OUT signal.

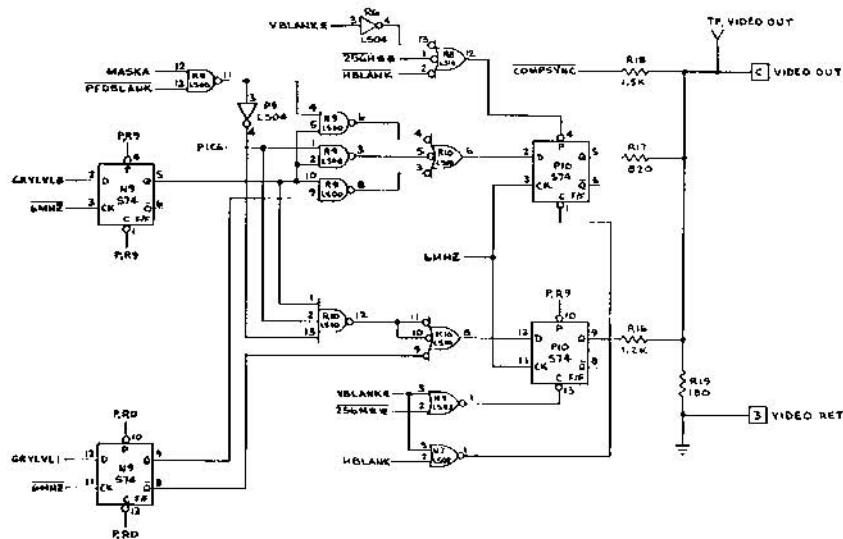

Figure 4-12 Video Output Schematic Diagram
(Part of Game PCB 034268-XX A)

h. trak ball control and switch input circuitry

(See Figure 4-13)

Both the left and right player START/SHOOT/JUMP switches and the left and right Trak Ball horizontal rate of turn information are read by the microprocessor on data lines DBUS0 thru DBUS3. The left and right Trak Ball vertical rate of turn information and vertical and horizontal direction of both Trak Balls are read by the MPU on data lines DBUS4 thru DBUS7.

Signals from the address decoder determine which signals are read by the MPU. When LD1 and LD2 are both low, the MPU reads both the player START/JUMP/SHOOT switches and the horizontal and vertical direction of turn of both Trak Balls. When LD1 is low and LD2 is high, the MPU reads the left and right Trak Ball horizontal rate from counters J9 and J10. When LD1 and LD2 are both high, the MPU reads the left and right Trak Ball vertical rate from counters H9 and H10.

The two coin switches, the TEST switch, the TEST STEP switch (used only during manufacturing), the SLAM switch and VBLANK are all read by the MPU through tristate buffers F11. The MPU accesses this information via address decode IN02.

The option switch toggles of J11 are all read by the MPU through tristate buffers H11. The MPU accesses this information via address decode IN03.

i. audio mixer/generator

(See Figure 4-14)

The audio mixer/generator produces crowd noise, NOTE and BOUNCE audio. The crowd sound is the result of the gated random noise generator composed of shift registers A10 and B10. The crowd sound volume is selected by the MPU through data bits DBUS0 thru DBUS3. The noise (unfiltered crowd sound) is filtered by the active band-pass filter circuit comprised of one quarter of op-amp B11 (LM324).

The NOTE signal is produced by counters D9 and D10. The MPU loads latch E10 with the period of the note to be produced. The counters load the period information from the latch each time the counters reach their maximum count.

BOUNCE audio is directly generated by the MPU thru data line DBUS4.

The three sounds are summed at the input of op-amp B11 (one quarter of LM324) and fed off the game PCB to the audio PCB for amplification.

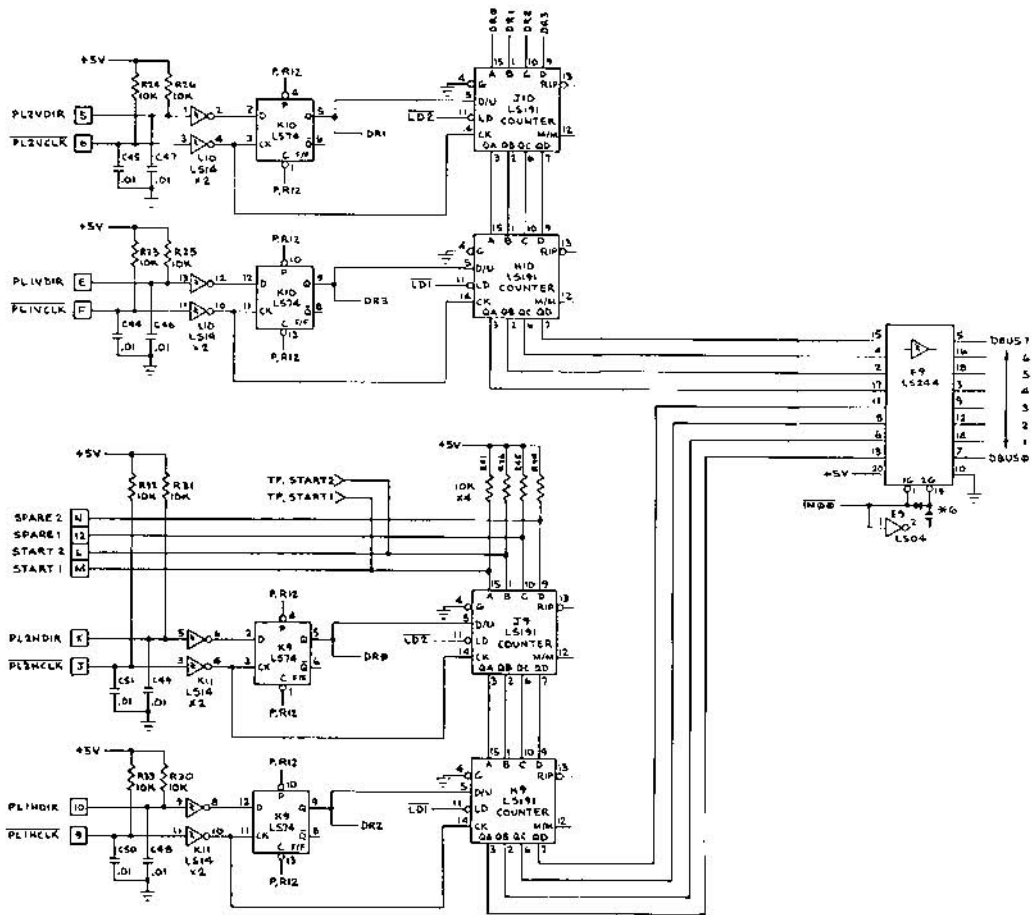
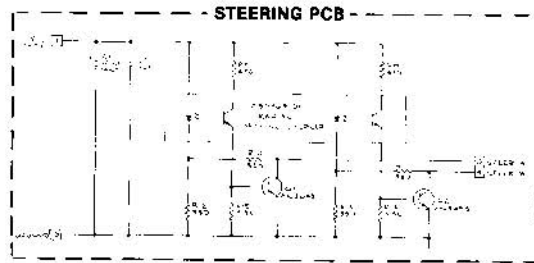

Figure 4-13 Trak Ball and Switch Input Schematic Diagram
(Part of Game PCB 034268-XX A)

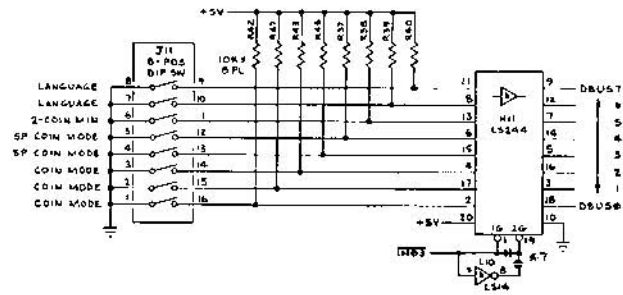
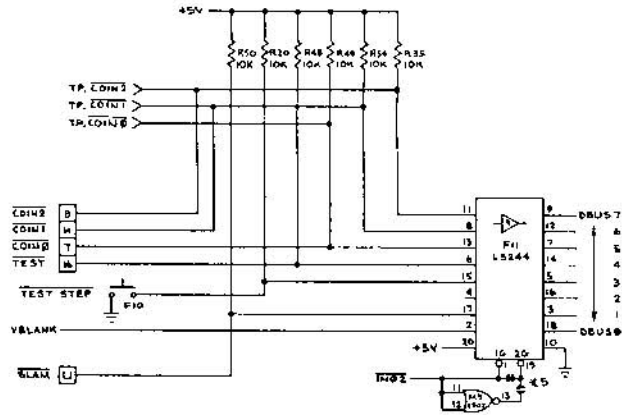

Figure 4-13 (Continued)

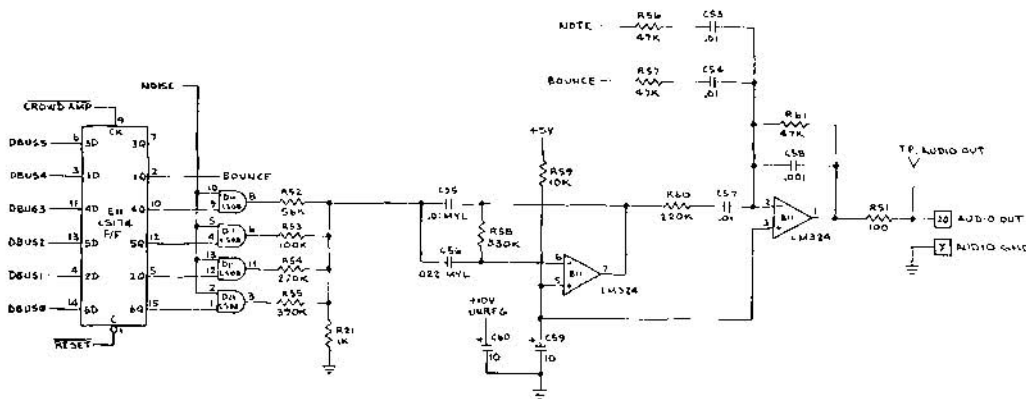
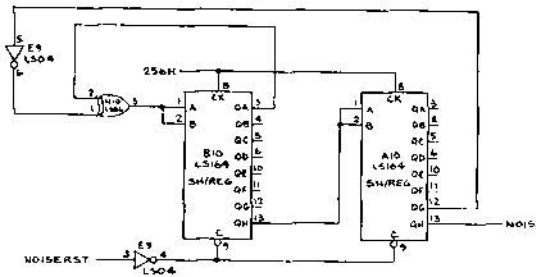
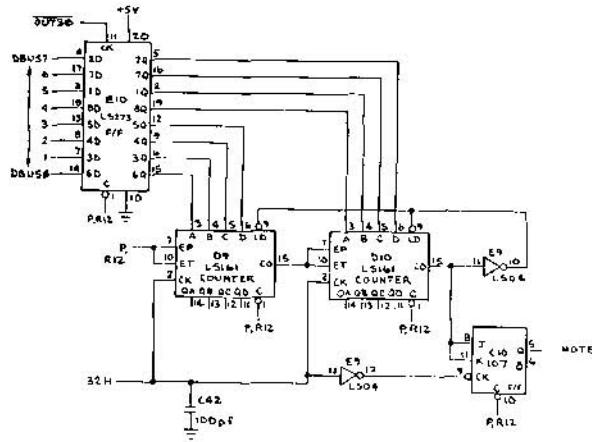
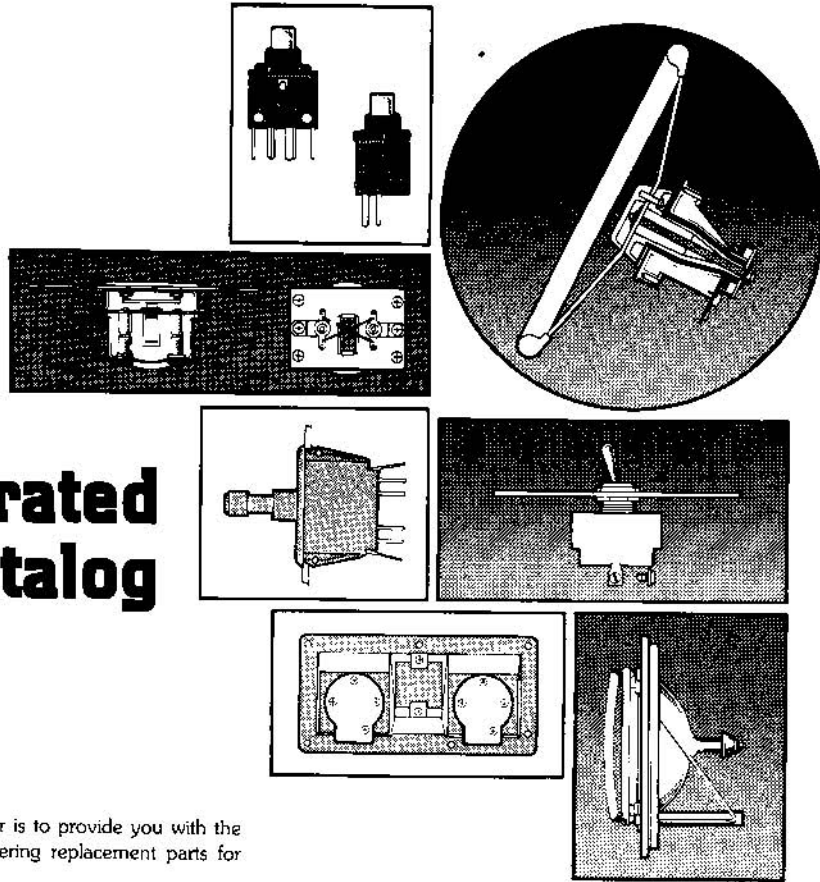

Figure 4-14 Audio Schematic Diagram
(Part of Game PCB 034268-XX A)

illustrated parts catalog

The purpose of this Chapter is to provide you with the necessary information for ordering replacement parts for your game.

When ordering parts from your distributor, give the part number, part name, applicable figure number from this Catalog, and the serial number of your game. This will help avoid confusion and mistakes in your order. We hope the result will be less down time and more profit from your game!



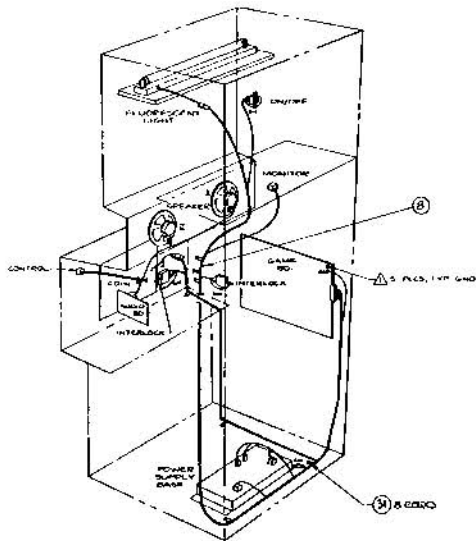
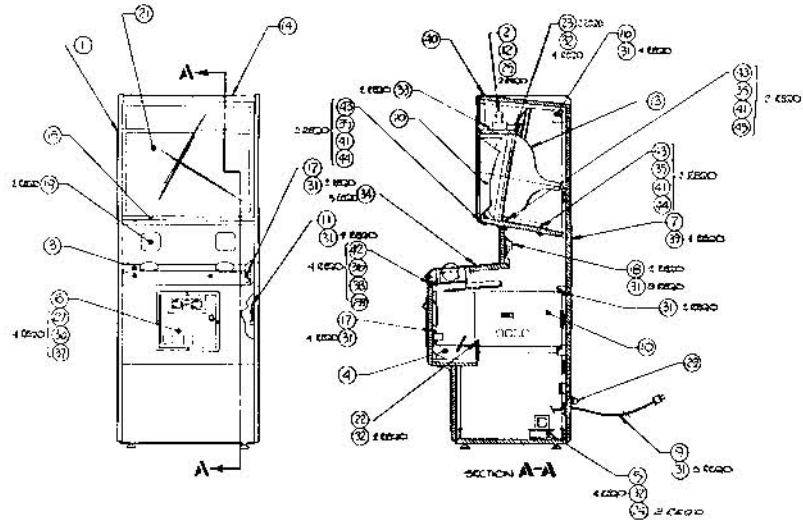

Figure 5-1 Final Assembly
034509-01 B

Figure 5-1 Final Assembly Parts List

Item	Part Number	Qty.	Description
1	A034349-01	1	Cabinet Assembly
2	A034352-01	1	Fluorescent Light Assembly (Figure 5-2)
3	A034355-01	1	Control Panel Assembly (Figure 5-3)
4	A007902-01	1	Cash Box Assembly
5	A007197-01	1	Type "B" Power Supply Assembly (Figure 5-6)
6	A009083-01	1	Coin Door Assembly (Figure 5-7)
7	A034353-01	1	Rear Door Assembly
8	A034543-01	1	Main Harness and Comp Assembly
9	A033016-01	1	Power Cord Assembly
10	A034268-01	1	Basketball PCB Assembly (Figure 5-8)
11	A009574-02	1	Audio Amplifier PCB Assembly (Figure 5-9)
12	70-301	1	24" Fluorescent Lamp
13	92-032	1	23" Black and White TV Monitor
14	034323-56	1	Upper Attraction Panel Retainer Strip
15	034356-01	1	Lower Attraction Panel Retainer Strip
16	009992-01	1	Power Switch Cover
17	007882-02	2	Interlock Switch Cover
18	48-004	2	8 Ohm, 5 Watt, 5" Loudspeaker
19	000869-01	2	5" Speaker Grille
20	034327 01	1	Bezel with Graphics
21	034326-01	1	Attraction Panel with Graphics
22	006870-01	1	Coin Box Bracket
23	005594-01	2	Monitor Tie-Down Bracket
24	46-2013002	2	3A, Type 3AG Slow-Blow Fuses
25	99-11006	2	Lamp Socket Clip
27	75-990505S	4	Hexagonal Polymer Self-Locking Steel Nut
28	75 045	4	1/4" Split Lock-Washer
29	78-25002	1	Screw-Down Tie Wrap
31	72-6610	37	#6 x 5/8" Pan-Head Self-Tapping Screw
32	72-6812	10	#8 x 3/4" Pan-Head Self-Tapping Screw
33	72-6820	2	#8 x 1 1/4" Pan-Head Self-Tapping Screw
34	034509	3	1/4" x 20 Flat-Head Cap Screw with Thread Locking Compound
35	75-010S	4	#10 Flat Steel Washer
36	75-015S	4	1/4" Flat Steel Washer
37	75-5520B	4	1/4" x 20 x 1.25" Black Oxide Carriage Bolt
38	75-935	4	1/4" x 20 Wing Nut
39	82-1824	4	#8 x 1 1/2" Flat-Head Wood Screw
40	82-8016	2	#10 x 32 x 1" Socket-Head Button Cap Screw
41	75-040B	6	#10 Black Split Lock-Washer
42	75-5523B	4	1/4" x 20 x 1.43" Black Carriage Bolt
43	75-5120B	4	#10 x 24 x 1.25" Black Carriage Bolt
44	75-911S	6	#10 x 24 Standard Pattern Steel Hexagonal Machine Nut
45	75-931	2	#10 x 24 Wing Nut



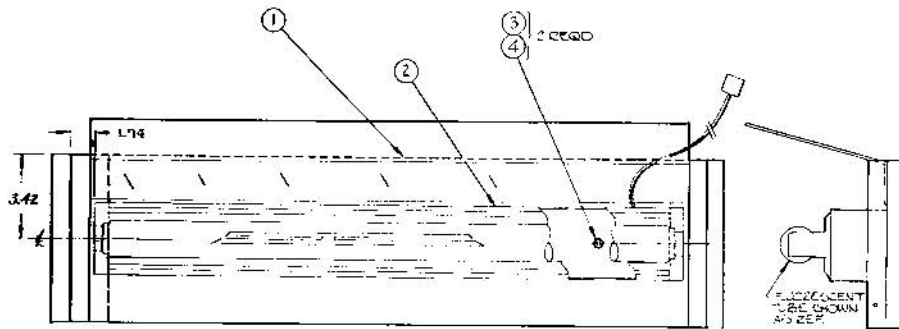
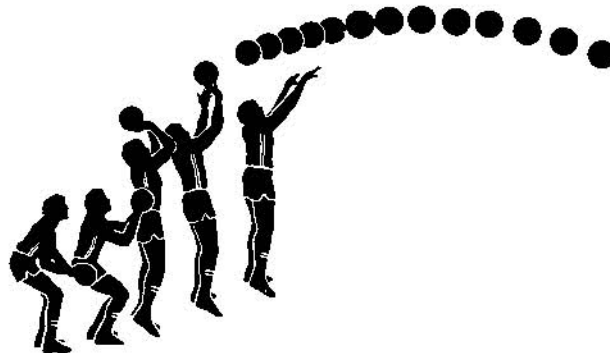

Figure 5-2 Fluorescent Light Assembly
A034352-01 B

Figure 5-2 Fluorescent Light Assembly Parts List

Item	Part Number	Qty.	Description
1	034335-01	1	Light Support Board
2	A034753-01	1	24" Fluorescent Light Assembly
3	72-68105	2	#8 x 5/8" Cross-Recessed Pan-Head Thread-Forming, Type AB Sheet-Metal Screw
4	75-018S	2	#8 Flat Washer



5-4 Basketball™

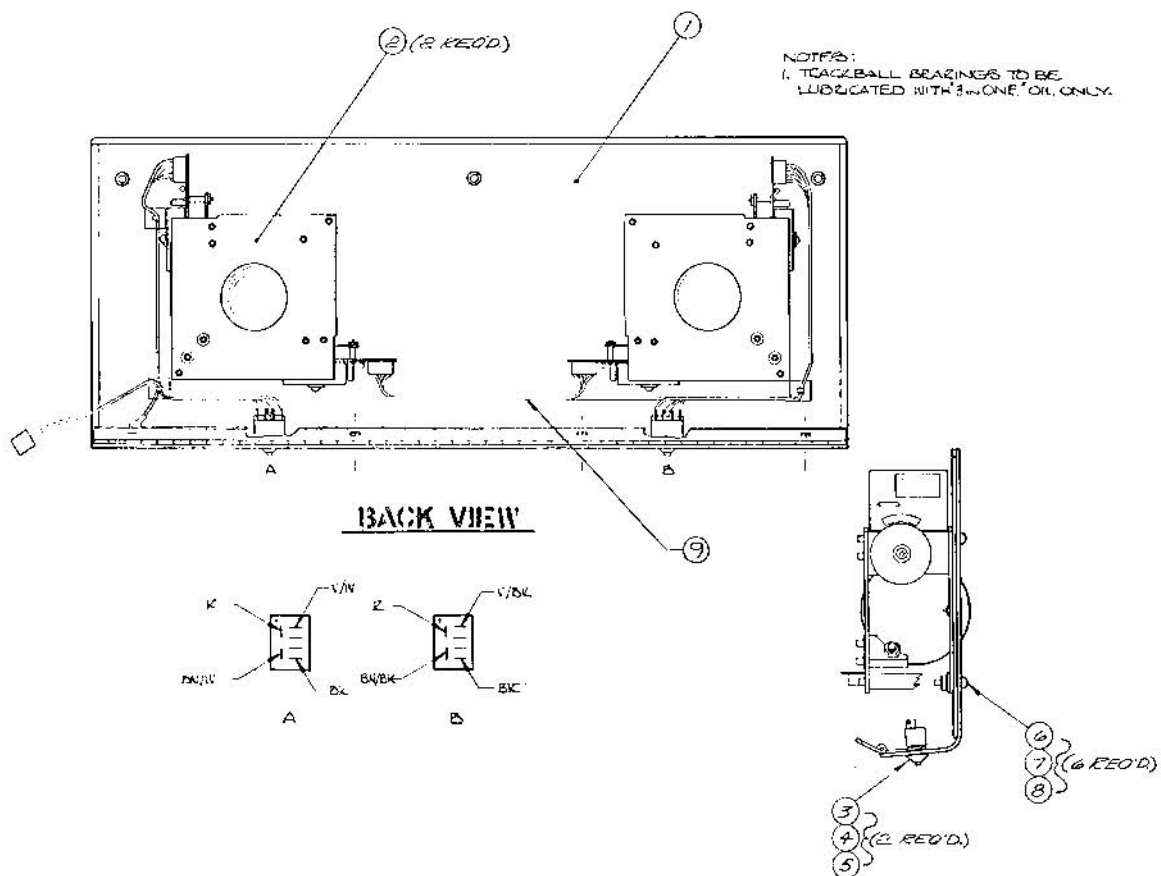

Figure 5-3 Control Panel Assembly
A034355-01 A

Figure 5-3 Control Panel Assembly
Parts List

Item	Part Number	Qty.	Description
1	034325-01	1	Control Panel with Graphics
2	A033360-01	2	Trak Ball™ Assembly (Figure 5-4)
3	033127-01	2	Black Switch Bushing (Start Switch)
4	62-002	2	Single Pole, Double Throw Pushbutton Type, Momentary Action Lighted (LED) Switch
5	75-07054	2	.47" I.D. by .968" O.D. x .075" Thick Flat Nylon Washer
6	75-5512N	6	1/4"-20 x 3/4" Round-Head, Square-Neck, Nickel Plated Carriage Bolt
7	75-015S	6	1/4" Flat Steel Washer
8	75-990505S	6	1/4"-20 Self-Locking Steel-Based Polymer Hexagonal Nut
9	A034543-01	1	Control Harness

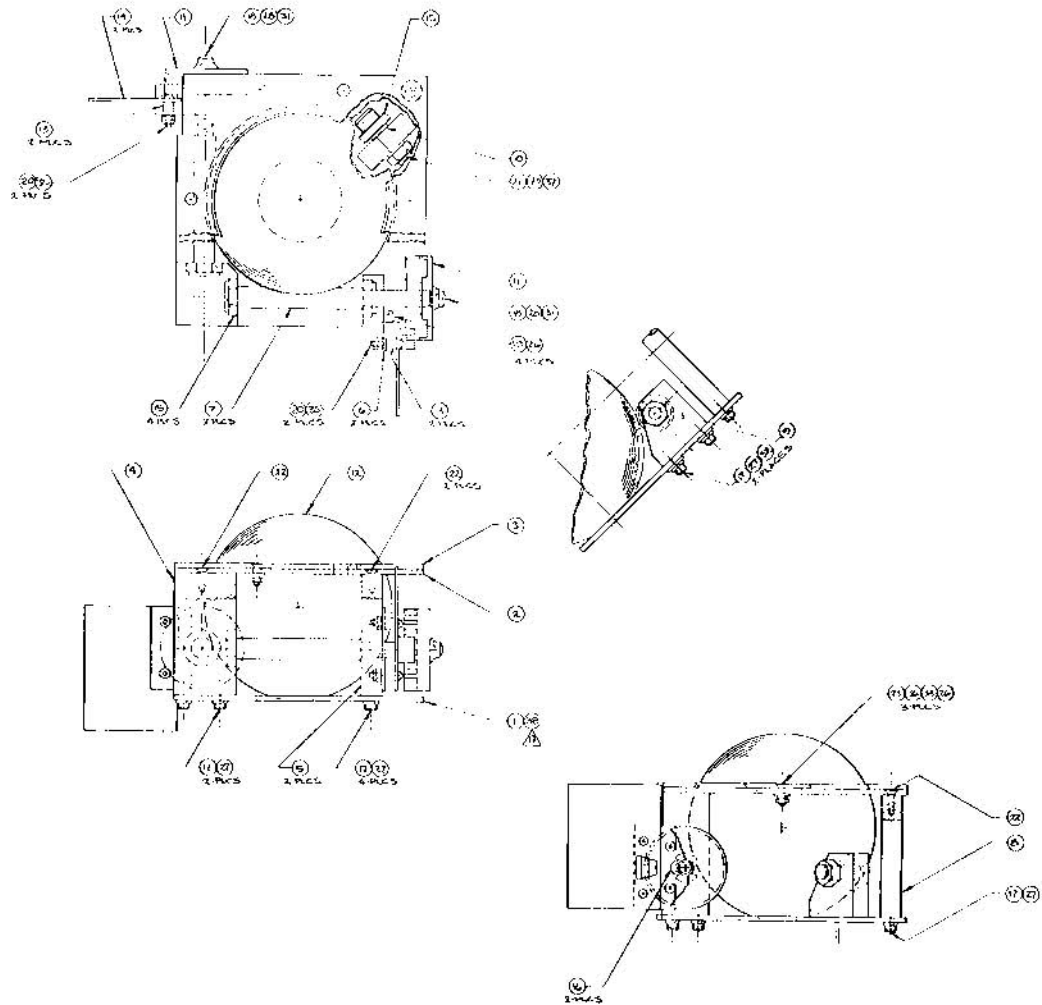

Figure 5-4 Trak Ball™ Assembly
A033360-01 F

5-6 Basketball™

Figure 5-4 Trak Ball™ Assembly
Parts List

Item	Part Number	Qty.	Description
1	033355-01	1	Base Plate
2	033356-01	1	Top Plate
3	033357-01	1	Cover Plate
4	033358-01	1	Corner Post
5	033359-01	2	End Post
6	033361-01	2	PCB Bracket
7	033362-01	2	Roller Shaft
8	033363-01	1	Stand Off
9	033364-01	1	Adjustable Post
10	033365-01	1	Spacer
11	000616-01	2	Light Hub
12	033366-01	1	4½" Diameter Rubber Ball
13	74-5404NN	4	1/8" I.D., ¼" O.D. × ¼" Nylon Spacer
14	A009060-02	2	Steering PCB Assembly (See Figure 5-5)
15	76-13003	5	Fafnir 53K or New Departures R6 Bearing
16	73-3006	2	3/8" Shaft Diameter Retaining Ring
17	72-8808	9	#8-32 × ½" Hex-Socket Machine Cap Screw
18	72-1006S	2	#10-32 × 3/8" Pan-Head, Cross-Recessed Cadmium-Plated steel Machine Screw
19	72-1606S	4	#6 32 × 3/8" Pan-Head, Cross-Recessed Cadmium-Plated Steel Machine Screw
20	72-1408S	4	#4-40 × ½" Pan-Head, Cross-Recessed Cadmium-Plated Steel Machine Screw
21	72-8920S	1	#3/8-16 × 1¼" Hexagonal Socket Machine Cap Screw
22	85-1808B	4	#8-32 × ½" Black Oxide Flat-Socket Head Cap Screw
23	75-3608S	3	#6-32 × ½" 82° Flat-Head Cross-Recessed Cadmium-Plated Steel Machine Screw
26	75-046S	4	#6 Corrosion-Resistant Steel Split Lock-Washer
27	75-048S	9	#8 Corrosion-Resistant Steel Split Lock-Washer
28	75-040S	2	#10 Corrosion-Resistant Steel Split Lock-Washer
29	75-041S	1	3/8" Corrosion-Resistant Steel Split Lock-Washer
31	75-010S	2	#10 Corrosion-Resistant Steel Flat, Plain Washer
32	75-018S	2	#8 Corrosion-Resistant Steel Flat, Plain Washer
33	75-016S	3	#6 Corrosion-Resistant Steel Flat, Plain Washer
35	75-990504C	4	#4-40 Steel Hexagonal Self-Locking, Shallow Pattern, Prevailing Torque Nut
36	75-916S	3	#6-32 Steel Standard Pattern Hexagonal Machine Nut
37	75-919S	1	3/8" Steel Standard Pattern Hexagonal Machine Nut



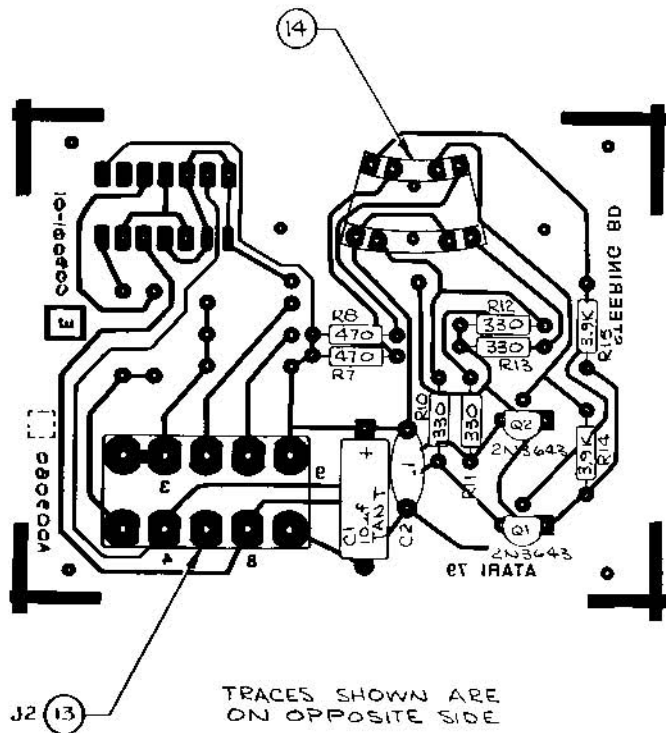

Figure 5-5 Steering Board Assembly
A009060-02 C

Figure 5-5 Steering Board Assembly
Parts List

Item	Part Number	Qty.	Description	Designation
5	10-5392	2	3.9k ohm, $\pm 5\%$ $\frac{1}{4}W$ Carbon Resistor	R14, 15
6	10-5331	4	330 ohm, $\pm 5\%$ $\frac{1}{4}W$ Carbon Resistor	R10-13
7	10-5471	2	470 ohm, $\pm 5\%$ $\frac{1}{4}W$ Carbon Resistor	R7, 8
8	27-250104	1	0.1 μf , $\pm 20\%$, 25V, Ceramic Disk Capacitor	C2
9	29-046	1	10 μf , $\pm 10\%$, 20V, Tantalum Axial Lead Capacitor	C1
10	34-2N3643	2	Transistor (2N3643)	Q1, 2
13	79-58005	1	10 Contact Connector	
14	030369-01	1	Radial Optical Coupler	

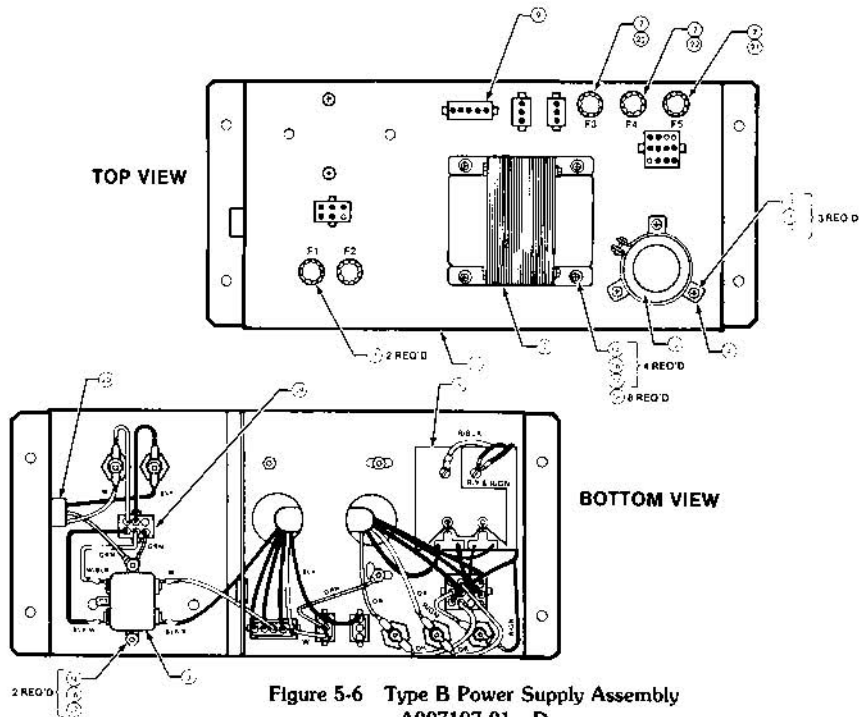

Figure 5-6 Type B Power Supply Assembly
A007197-01 D

Figure 5-6 Type B Power Supply Assembly Parts List

Item	Part Number	Qty.	Description
1	A009266-01	1	Power Supply Base Weldment Assembly
2	A006886-01	1	Type B Transformer Termination Assembly, Type B
3	29-053	1	Sprague 26,000 μ f. 15V Electrolytic Capacitor, Type 36DX263G015BM2B
4	78-70501SC	1	Sprague #4586-48 Capacitor Mounting Bracket
5	A006555-01	1	P.C. Board Rectifier
7	79-4411004	5	Panel Mounting Fuse Holder
8	41-2003	1	5-Amp Power Line Filter
9	A006958-01	1	Voltage Selection Block, (95V - Black)
10	A006858-02	1	Voltage Selection Block, (110V - Orange)
11	A006858-03	1	Voltage Selection Block, (205V - Green)
12	A006858-04	1	Voltage Selection Block, (220V - Red)
14	72-1810S	9	#8-32 \times 5/8" Pan-head Steel Screw
16	75-048	9	#8 Split Lock-Washer
17	75-918S	9	#8 Steel Hexagonal Machine Nut
18	75-018S	8	#8 Flat Steel Washer
19	A007192-01	1	Power Switch Termination
20	A007444-01	1	Power in Harness
21	46-203801	1	8 Amp, 125 Volt Fast-Blow Type 3AG Fuse
22	46-201251	2	2.5 Amp, 125 Volt Slow-Blow Type 3AG Fuse

Figure 5-7 Coin Door Assembly
Parts List

Item	Part Number	Qty.	Description
1	A007637-01	1	Front Bezel Assembly -01 coin door assy. only—(25 ¢)
	A007637-02	Ref.	Front Bezel Assembly -02 coin door assy. only—(5 Fr.)
	A007637-03	Ref.	Front Bezel Assembly -03 coin door assy. only—(1 DM)
	A007637-04	Ref.	Front Bezel Assembly -04 coin door assy.—(1 Kr)
	A007637-05	Ref.	Front Bezel Assembly -05 coin door assy. only—(100 Y)
	A007637-06	Ref.	Front Bezel Assembly -06 coin door assy. only—(10 pence)
	A007637-07	Ref.	Front Bezel Assembly -07 coin door assy. only—(20 Australian)
2	75-9165	4	#6-32 Nut
3	A030362-01	1	Coin Lock-out Assembly
4	A007640-01	2	Coin Switch Assembly
5	A002465-01	1	Coin Counter Assembly
6	004320-01	1	Coin Door Weldment
7	004341-01	2	Secondary Coin Chute
8	004344-01	1	Key Loop
9	004340-01	2	Spring Return
10	004337-01	2	Wire Form Bracket
11	004338-01	1	R.H. Lock-Out Wire Form
12	004336-01	1	L.H. Lock-Out Wire Form
13	004326-01	2	Scavenger Button
14	75-046	4	#6 Lockwasher
15	006904-01	2	Spacer
16	007359-01	1	Lamp socket
17	70-11-47	1	Lamp
18	73-3008	2	Truarc #5103-25 Retaining "C" Ring
19	75-9914001	6	Self-Threading Tinnerman Nut, #SR188006
20	75-026S	4	#6 Washer
21	75-00516	13	#6-32 Style #842 Steel Kepnut
22	008629-01	2	Spring
23	71-2118	1	Lock assembly
24	71-1225CU	2	Coin Mechanism for American Quarter Only
	71-125FB	Ref.	Coin Mechanism for Belgian 5 Francs Only
	71-1205MG	Ref.	Coin Mechanism for German Mark Only
	71-1201KS	Ref.	Coin Mechanism for Swedish Krona Only
	71-1201YJ	Ref.	Coin Mechanism for Japanese 100 Yen Only
	71-1210PE	Ref.	Coin Mechanism for English 10 Pence Only
	71-1220CA	Ref.	Coin Mechanism for Australian 20-Cent Piece Only
25	007753-01	1	Anti-probe Plate
26	A007638-01	1	Slam Switch Assembly
27	A006921	1	Harness Assembly



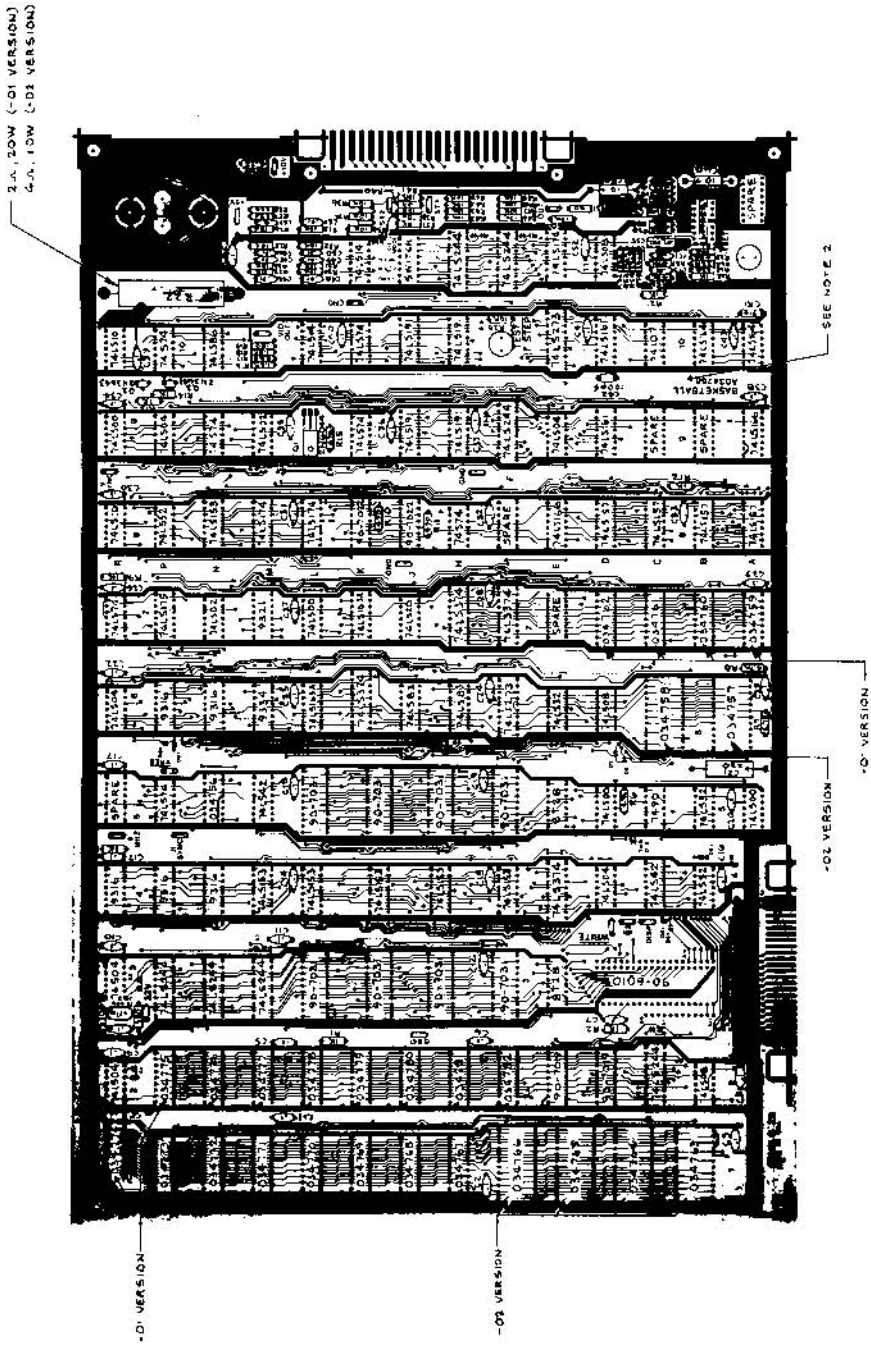

Figure 5-8 Basketball Game PCB Assembly
A034268-01 A

Figure 5-8 Basketball Game PCB Assembly
Parts List

Item	Part Number	Qty.	Description	Designation
1	034269-01	1	Printed Circuit Board	
2	10-5101	1	100 ohm, $\pm 5\%$, $\frac{1}{4}$ Watt, Carbon Resistor	R51
3	10-5221	3	220 ohm, $\pm 5\%$, $\frac{1}{4}$ Watt, Carbon Resistor	R27,28,63
4	10-5331	2	330 ohm, $\pm 5\%$, $\frac{1}{4}$ Watt, Carbon Resistor	R3,4
5	10-5471	3	470 ohm, $\pm 5\%$, $\frac{1}{4}$ Watt, Carbon Resistor	R10,11,12
6	10-5102	9	1 k-ohm, $\pm 5\%$, $\frac{1}{4}$ Watt, Carbon Resistor	R1,2,5,9,12- 14,21,62
7	10-5152	1	1.5 k-ohm, $\pm 5\%$, $\frac{1}{4}$ Watt, Carbon Resistor	R18
8	10-5472	3	4.7 k-ohm, $\pm 5\%$, $\frac{1}{4}$ Watt, Carbon Resistor	R6-8
9	10-5103	28	10 k-ohm, $\pm 5\%$, $\frac{1}{4}$ Watt, Carbon Resistor	R20,23 26,30-50, 59,66
10	10-5223	1	22 k-ohm, $\pm 5\%$, $\frac{1}{4}$ Watt, Carbon Resistor	R64
11	10-5473	3	47 k-ohm, $\pm 5\%$, $\frac{1}{4}$ Watt, Carbon Resistor	R56,57,61
12	10-5563	1	56 k-ohm, $\pm 5\%$, $\frac{1}{4}$ Watt, Carbon Resistor	R52
13	10-5683	1	68 k-ohm, $\pm 5\%$, $\frac{1}{4}$ Watt, Carbon Resistor	R65
14	10-5104	1	100 k-ohm, $\pm 5\%$, $\frac{1}{4}$ Watt, Carbon Resistor	R53
15	10-5224	2	220 k-ohm, $\pm 5\%$, $\frac{1}{4}$ Watt, Carbon Resistor	R54,60
16	10-5334	1	330 k-ohm, $\pm 5\%$, $\frac{1}{4}$ Watt, Carbon Resistor	R58
17	10-5394	1	390 k-ohm, $\pm 5\%$, $\frac{1}{4}$ Watt, Carbon Resistor	R55
18	19-10020001	1	2 ohm, 20 Watt Wirewound Resistor	R22
20	21-101223	1	.022 μ f, $\pm 10\%$, 100V Mylar Capacitor	C56
21	21-101103	1	.01 μ f, $\pm 10\%$, 100V Mylar Capacitor	C55
22	24-250106	2	10 μ f, (-)10%, $\pm 50\%$, 25V Electrolytic Capacitor	C59,60
23	24-250227	1	220 μ f, -10%, $\pm 50\%$, 25V Electrolytic Capacitor	C21
24	27-250103	11	.01 μ f, 20%, 25V Ceramic Disk Capacitor	C44-51,53, 54,57
25	27-250104	44	0.1 μ f, $\pm 20\%$, 25V Ceramic Disk Capacitor	C1-20,22-41, 43,52,62,63
26	27-250102	1	.001 μ f, 20%, 25V, Ceramic Disk Capacitor	C58
27	27-250224	1	.22 μ f, 20%, 25V, Ceramic Disk Capacitor	C61
28	28-101101	1	100 pF, $\pm 5\%$, 25V Mica Capacitor	C42
31	31-1N914	1	1N914 Diode	CR1
32	34-2N3643	2	2N3643 Transistor	Q2,Q3
33	34-2N6044	1	2N6044 Transistor	Q1
35	37-74LS00	4	Integrated Circuit, 74LS00	A5,D5,L7,R9
36	37-74LS02	3	Integrated Circuit, 74LS02	N7,M9
37	37-74LS04	5	Integrated Circuit, 74LS04	D4,R6,E9, P9,R2
38	37-74S04	1	Integrated Circuit, 74S04	R3
40	37-74LS08	3	Integrated Circuit, 74LS08	B2,D6,D11
41	37-74LS10	2	Integrated Circuit, 74LS10	R8,R10



Figure 5-8 Basketball Game PCB Assembly Parts List, continued

Item	Part Number	Qty.	Description	Designation
42	37-74LS14	2	Integrated Circuit, 74LS14	L10,K11
44	37-74LS20	1	Integrated Circuit, 74LS20	J7
45	37-74LS32	4	Integrated Circuit, 74LS32	B4,B5,E6,P8
46	37-74LS42	2	Integrated Circuit, 74LS42	C4,M5
47	37-74LS74	4	Integrated Circuit, 74LS74	P5,R7,K9, K10
48	37-74S74	3	Integrated Circuit, 74S74	H8,N9,P10
49	37-74LS83	2	Integrated Circuit, 74LS83	H6,J6
50	37-74LS86	1	Integrated Circuit, 74LS86	N10
51	37-7490	1	Integrated Circuit, 7490	C5
52	37-74107	1	Integrated Circuit, 74107	C10
54	37-74LS153	6	Integrated Circuit, 74LS153	F4,H4,K4,L4, M4,N8
55	37-74LS157	4	Integrated Circuit, 74LS157	A8,B8,C8,D8
56	37-74LS161	2	Integrated Circuit, 74LS161	D9,D10
57	37-74LS163A	2	Integrated Circuit, 74LS163A	L6,K7
58	37-74LS164	2	Integrated Circuit, 74LS164	A10,B10
59	37-74LS166	2	Integrated Circuit, 74LS166	A9,E8
60	37-74LS174	3	Integrated Circuit, 74LS174	L8,M8,E11
61	37-74LS175	1	Integrated Circuit, 74LS175	P7
62	37-74LS191	4	Integrated Circuit, 74LS191	H9,J9,H10, J10
63	37-74LS244	7	Integrated Circuit, 74LS244	C2,M3,N3, P3,F9 F11, H11
64	37-74LS273	2	Integrated Circuit, 74LS273	F6,E10
65	37-74LS374	4	Integrated Circuit, 74LS374	E4,K6,F7,H7
66	37-8T28	2	Integrated Circuit, 8T28	E3,E5
68	37-9316	5	Integrated Circuit, 9316	N4,P4,R- 4,N6, P6
69	37-9321	1	Integrated Circuit, 9321	M7
70	37-9334	1	Integrated Circuit, 9334	M6
71	37-LM323K	1	LM323 Regulator I.C.	
72	37-LM324	1	LM324 Audio Amplifier I.C.	B11
74	62-001	2	SPST Momentary Contact Switch	F10,A11
75	66-118PIT	1	SPST x 8 DIP Switch	J11
77	81-4302	1	Nylon Snap-in Fastener	Q1
78	72-1608C	2	#6-32 x 1/2" Cross-Recessed Pan-Head, Corrosion-Resistant Steel Machine Screw	
79	75-016C	2	#6 Flat Corrosion-Resistant Steel Washer	
80	75-056C	2	#6 Internal Tooth Corrosion-Resistant Steel Lock-Washer	
81	75-916C	2	#6-32 Hexagonal Corrosion-Resistant Steel Machine Nut	



Figure 5-8 Basketball Game PCB Assembly Parts List, continued

Item	Part Number	Qty.	Description	Designation
83	78-06001	1	Heatsink (LM323K)	
84	78-16005	1	Slipad (LM323K)	
86	009470	2	Heatsink (82517)	
89	79-42C40	1	40 pin Medium Insertion Socket	C3
93	90-102	1	12.096 MHz Crystal	Y1
95	90-6010	1	6502 Microprocessor	C3
97	90-7019	2	2111A-4 RAM	D2, E2
98	90-7022	2	82517 OR 82516 RAM	J8, K8
100	90-7031	8	2101A-4 RAM	F3, H3, K3, L3, F5, H5, K5, L5
102	034756-01	1	Sync PROM	N6
104	034759-01	1	PROM A1 PROM	A7
105	034760-01	1	PROM A0 PROM	B7
106	034761-01	1	PROM B1 PROM	C7
107	034762-01	1	PROM B0 PROM	D7

NOTE: See program memory table of equivalents

Program (ROM) Memory Table of Equivalents

Self-Test Display	-01 PCB (1K x 4 PROM Chips)		-01 PCB (2K x 4 PROM Chips)		-02 PCB (4K x 8 ROMs)	
	Atari P/N	Chip Loc.	Atari P/N	Chip Loc.	Atari P/N	Chip Loc.
ROM BAD A	034774	R1	034790	R1	034765	D/E1
ROM BAD C	034778	L2				
ROM BAD B	034770	L1	034786	L1		
ROM BAD D	034782	F2				
ROM BAD E	034772	N1	034788	N1	034764	C/D1
ROM BAD G	034776	N2				
ROM BAD F	034768	J1	034784	J1		
ROM BAD H	034780	J2				
ROM BAD I	034773	P1	034789	P1	034766	F1
ROM BAD K	034775	P2				
ROM BAD J	034767	H1	034783	H1		
ROM BAD L	034781	H2				
ROM BAD M	034771	M1	034787	M1	034763	B1
ROM BAD O	034777	M2				
ROM BAD N	034769	K1	034785	K1		
ROM BAD P	034779	K2				

NOTE: If your game PCB has the suffix "-01" after its serial number, it may use either the 1k or 2k PROM chips. Install the replacements in the positions shown in this table. If your game PCB has the suffix "-02" after its serial number, it is supplied with the 4K x 8 ROMs as shown in the table, and these should be replaced only with identical chips.



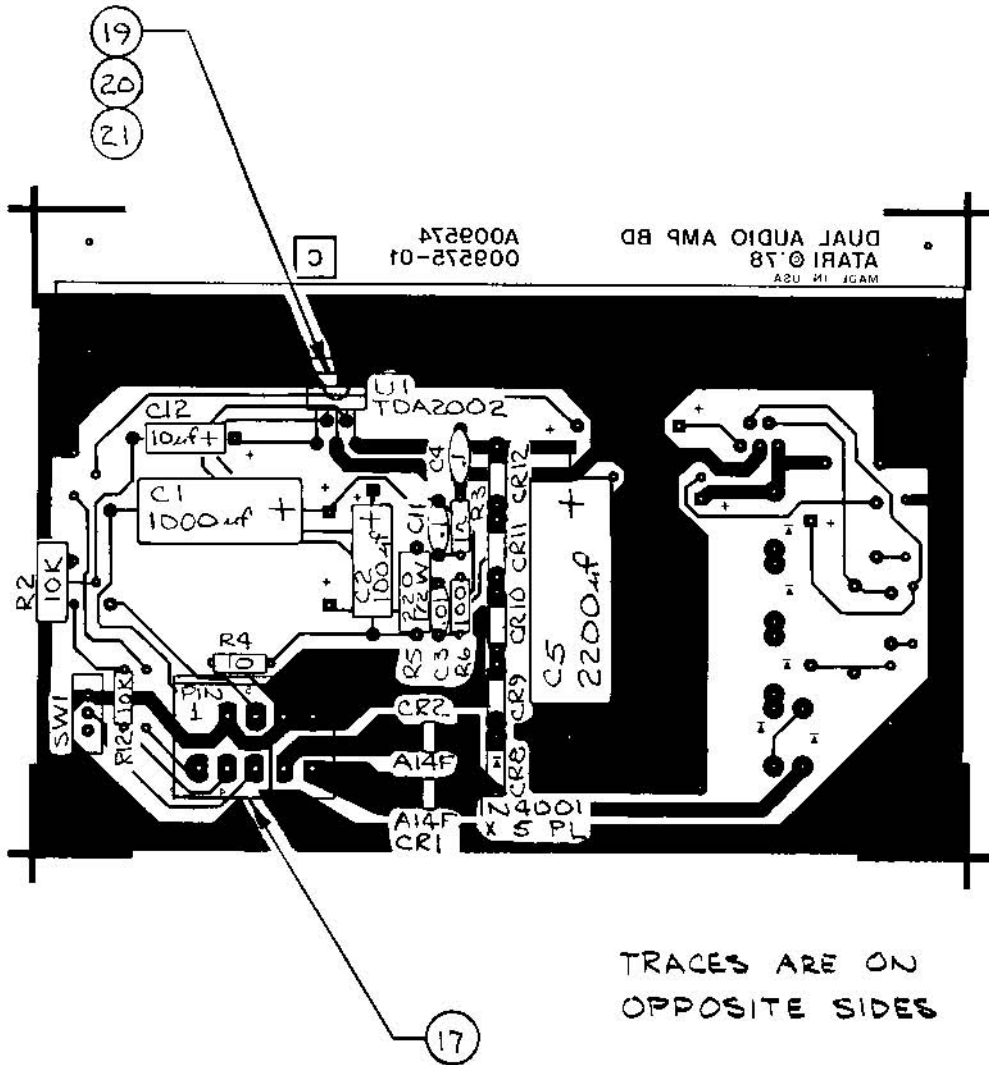

Figure 5-9 Audio PCB Assembly
A009574-01 C

Figure 5-9 Audio PCB Assembly
Parts List

Item	Part Number	Qty	Description	Designation
2	10-51PO	1	1 Ohm, $\pm 5\%$, $\frac{1}{4}$ Watt, Carbon Resistor	R3
3	10-5101	1	100 Ohm, $\pm 5\%$, $\frac{1}{4}$ Watt, Carbon Resistor	R6
4	10-5100	1	10 Ohm, $\pm 5\%$, $\frac{1}{4}$ Watt, Carbon Resistor	R4
5	11-5221	1	220 Ohm, $\pm 5\%$, $\frac{1}{2}$ Watt, Carbon Resistor	R5
6	19-316103	1	10K-Ohm Trimpot	R2
7	24-250106	1	25V, 10 μ f -10%, +50% Electrolytic Cap.	C12
8	24-240107	1	25V, 100 μ f -10%, +50% Electrolytic Cap.	C2
9	24-250108	1	25V, 1000 μ f -10%, +50% Electrolytic Cap.	C1
10	24-250228	1	25V, 2200 μ f -10%, +50% Electrolytic Cap.	C5
11	27-101103	1	100V, .01 μ f -20%, +50% Ceramic Disc Cap.	C3
12	27-250104	2	25V, 0.1 μ f $\pm 20\%$ Ceramic Disc Cap.	C4, 11
13	31-A14F	2	A14F, 50 PIV High Current Rectifier	CR1, 2
14	31-1N4001	5	1N4001 Diode	CR8-CR12
15	37-TDA2002V	1	TDA2002V Audio Amp.	V1
16	69-004	1	Slide Switch	SW1
17	78-58005	1	10 Contact Connector	
18	030184-01	1	Heat Sink	
19	72-1604C	3	#6-32 \times $\frac{1}{4}$ " Pan-Head Cross-Recessed Steel Machine Screw	
20	75-056	3	#6 Interior Star Lock Washer	
21	78-16009	1	Silpad $\pm 5\%$	
22	10-5103	1	10K-Ohm, $\pm 5\%$ $\frac{1}{4}$ Watt Carbon Resistor	R12

